

Allen-Bradley

Ultra3000 Digital Servo Drives

(Catalog Numbers
2098-DSD-005, -010, and -020
2098-DSD-xxxX
2098-DSD-xxx-SE
2098-DSD-xxx-DN
2098-DSD-xxxX-DN

2098-DSD-030, -075, and -150
2098-DSD-xxxX
2098-DSD-xxx-SE
2098-DSD-xxx-DN
2098-DSD-xxxX-DN

2098-DSD-HV030, -HV050, -HV100, -HV150,
and -HV220
2098-DSD-HVxxxX
2098-DSD-HVxxx-SE
2098-DSD-HVxxx-DN
2098-DSD-HVxxxX-DN)

Installation Manual

**Rockwell
Automation**

Important User Information

Because of the variety of uses for the products described in this publication, those responsible for the application and use of this control equipment must satisfy themselves that all necessary steps have been taken to assure that each application and use meets all performance and safety requirements, including any applicable laws, regulations, codes and standards.

The illustrations, charts, sample programs and layout examples shown in this guide are intended solely for purposes of example. Since there are many variables and requirements associated with any particular installation, Allen-Bradley® does not assume responsibility or liability (to include intellectual property liability) for actual use based upon the examples shown in this publication.

Allen-Bradley publication SGI-1.1, *Safety Guidelines for the Application, Installation and Maintenance of Solid-State Control* (available from your local Allen-Bradley office), describes some important differences between solid-state equipment and electromechanical devices that should be taken into consideration when applying products such as those described in this publication.

Reproduction of the contents of this copyrighted publication, in whole or part, without written permission of Rockwell Automation®, is prohibited.

Throughout this manual we use notes to make you aware of safety considerations:

ATTENTION



Identifies information about practices or circumstances that can lead to personal injury or death, property damage or economic loss.

Attention statements help you to:

- identify a hazard
- avoid a hazard
- recognize the consequences

IMPORTANT

Identifies information that is critical for successful application and understanding of the product.

Allen-Bradley, A-B, ControlLogix, and Rockwell Automation are registered trademarks of Rockwell Automation.
RSLogix, RSLogix 5000, SoftLogix, and Ultra3000 are trademarks of Rockwell Automation.
DeviceNet is a trademark of the Open DeviceNet Vendor Association.
SERCOS interface is a trademark of the Interests Group SERCOS interface e.V. (IGS).
Windows is a registered trademark of Microsoft Corporation.
UL is a registered trademark of Underwriters Laboratories, Inc.
Bussmann is a registered trademark of Cooper Industries, Inc.
LittellFuse is a registered trademark of LittellFuse.

The Ultra3000 Digital Servo Drive Installation Manual Document Update, publication 2098-DU003B-EN-P, includes important information about changes and updates to this Ultra3000 Digital Servo Drive Installation Manual.

The document update used to be provided as a separate document, but is now incorporated into this installation manual, in the section immediately following this Summary of Changes section, and before the Table of Contents.

Before using this installation manual, read and understand the changes and updates identified in the document update section.

No engineering or editorial changes have been made to either the document update or the installation manual; therefore, the publication dates and revisions of each respective manual did not change. The publication date of this Summary of Changes section indicates the date that the combined manuals were released.

Notes:



Ultra3000 Digital Servo Drive Installation Manual

Catalog Numbers

2098-DSD-005, -010, and -020

2098-DSD-xxxX

2098-DSD-xxxSE

2098-DSD-xxx-DN

2098-DSD-xxxX-DN

2098-DSD-030, -075, and -150

2098-DSD-xxxX

2098-DSD-xxxSE

2098-DSD-xxx-DN

2098-DSD-xxxX-DN

2098-DSD-HV030, -HV050, -HV100, -HV150, and -HV220

2098-DSD-xxxX

2098-DSD-xxxSE

2098-DSD-xxx-DN

2098-DSD-xxxX-DN

About This Publication

This document updates information about the Ultra3000 digital servo drive products. Use this document in conjunction with the Ultra3000 Digital Servo Drive Installation Manual, publication 2098-IN003E-EN-P. To obtain a copy, contact your local Rockwell Automation sales office, distributor, or online at <http://literature.rockwellautomation.com>.

Page 2-52

Replace Figure 2.57 on page 2-52 with the one shown below. The new figure correctly identifies the drive connector as CN3.

Figure 2.57
RS-232 to RS-485 Connection Diagram

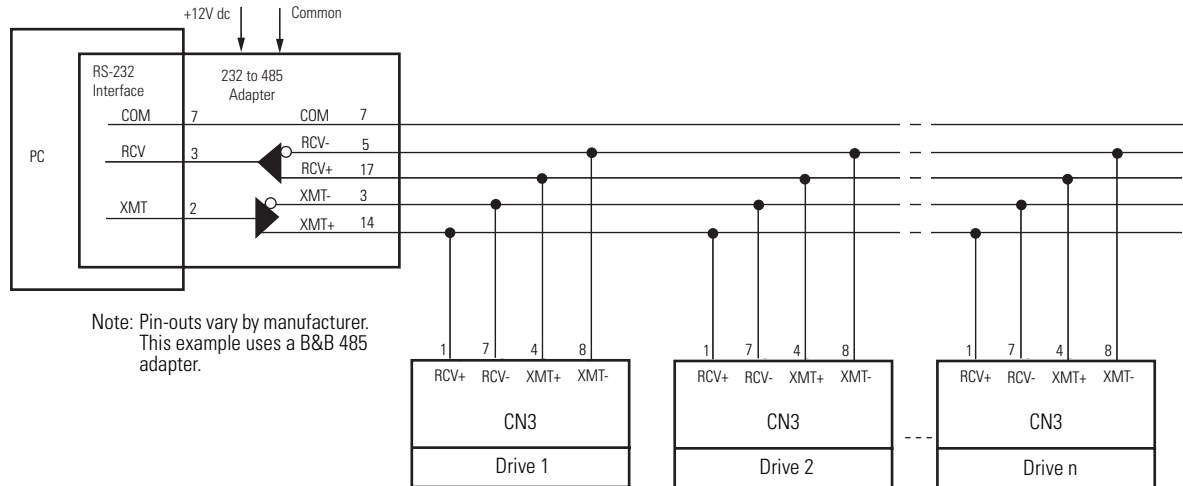

Page 4-3

Update the Error Codes table beginning on page 4-3 with the following entries:

- Replace the error code entry for E02. In the new entry, the reference to firmware revisions prior to 1.10 is removed.
- Replace the error code entry for E03. In the new entry, the reference to firmware revisions prior to 1.10 is added.
- Add the lost motion fault (E44).

Error Codes

Error Code	Problem or Symptom	Possible Cause	Action/Solution
E02	Velocity exceeds position rollover /2	The velocity command or feedback exceeds half the machine cycle length per millisecond (applies only when the machine cycle position rollover is enabled).	Increase machine cycle size or reduce velocity profile.
E03	Absolute feedback range exceeded	The motor position exceeds +/- 2047 revolutions from the home position (applies only to systems with absolute feedback).	<ul style="list-style-type: none"> • Decrease application range of motion. • Upgrade firmware. This error only applies to firmware revisions prior to 1.10.
E44	Lost motion fault (only applies to applications with Stegmann feedback devices)	Detection occurs during a fault reset. Absolute position in the drive is incorrect and the motion has been lost due to line loss condition.	<ul style="list-style-type: none"> • Cycle power. • Cycle power and re-home drive if drive was homed in the same power cycle that the lost motion fault occurred.

Page A-2

Replace the Ultra3000 (230V) Power Specifications table on page A-2 with the one shown below. The new table includes inrush current specifications configured as Series A, B, or C.

- Ultra3000 drive firmware revision 1.45 is required to support the Series C hardware.
- Ultraware software, version 1.63, is required to download firmware to Series C drives containing the new power board.

Ultra3000 Drive (230V) Power Specifications

2098-DSD-005x-xx, 2098-DSD-010x-xx, and 2098-DSD-020x-xx

Specification	Description		
	2098-DSD-005	2098-DSD-010	2098-DSD-020
AC input voltage ⁽¹⁾	100...240V rms single-phase		
AC input frequency	47...63 Hz		
AC input current ^{(2) (3)} Nom (rms) 230V ac (0-pk) max inrush ⁽⁴⁾	5 A 100 A - Series A or B 20 A - Series C	9 A 100 A - Series A or B 20 A - Series C	18 A 100 A - Series A or B 20 A - Series C
Continuous output current (0-pk)	2.5 A	5 A	10 A
Intermittent output current (0-pk)	7.5 A	15 A	30 A
Bus capacitance	1410 μ F	1880 μ F	1880 μ F
Internal shunt resistance	N/A	N/A	N/A
Shunt on	N/A	N/A	N/A
Shunt off	N/A	N/A	N/A
Bus overvoltage	400V dc	400V dc	400V dc
Energy absorption capability 115V ac input 230V ac input	93 J 38 J	125 J 51 J	
Continuous power output 115V ac input 230V ac input	0.25 kW 0.5 kW	0.5 kW 1.0 kW	1.0 kW 2.0 kW

⁽¹⁾ Specification is for nominal voltage. The absolute limits are $\pm 10\%$, or 88...265V rms.

⁽²⁾ The 2098-DSD-005x-xx, -010x-xx, and -020x-xx (230V) drives are limited to:
Series A or B - one contactor cycle every two minutes.
Series C - one contactor cycle every 10 s for up to two minutes, not to exceed 12 cycles in five minutes.

⁽³⁾ Power initialization requires a short period of inrush current. Dual-element time delay (slow blow) fuses are recommended.

⁽⁴⁾ Inrush current-limiting circuitry is enabled within 3 s after removal of ac line power.

ATTENTION



The inrush current-limiting circuitry is limited in the number of power cycles it can withstand within a set period of time. If you exceed these limitations, the circuitry will be damaged.

Page A-3

Replace the Ultra3000 (230V) Power Specifications table on page A-3 with the one shown below. The new table includes an updated value in the bus capacitance field for 2098-DSD-030 drives.

Ultra3000 Drive (230V) Power Specifications

2098-DSD-030x-xx, 2098-DSD-075x-xx, and 2098-DSD-150x-xx

Specification	Description		
	2098-DSD-030	2098-DSD-075	2098-DSD-150
AC input voltage ⁽¹⁾	100...240V rms Single-phase	100...240V rms Three-phase	
AC input frequency	47...63 Hz		
Main ac input current ⁽²⁾⁽³⁾ Nom (rms) 230V ac (0-pk) Max inrush	28 A 50 A	30 A 50 A	46 A 68 A
Auxiliary ac Input current 115V ac (rms) Nom 230V ac (rms) Nom 115V ac (0-pk) Max inrush ⁽⁴⁾ 230V ac (0-pk) Max inrush ⁽⁴⁾	1.0 A 0.5 A 47 A 95 A	1.0 A 0.5 A 47 A 95 A	1.0 A 0.5 A 47 A 95 A
Continuous output current (0-pk)	15 A	35 A	65 A
Intermittent output current (0-pk)	30 A	75 A	150 A
Bus capacitance	2820 μ F	4290 μ F	7520 μ F
Internal shunt resistance	35 Ω	16.5 Ω	9.1 Ω
Shunt on	420V dc	420V dc	420V dc
Shunt off	402V dc	402V dc	402V dc
Bus overvoltage	452V dc	452V dc	452V dc
Internal shunt Continuous power Peak power	50 W 4.5 kW	50 W 10 kW	180 W 18 kW
External shunt Resistance Continuous power Peak power	30 Ω (-0/+5%) 2.4 kW 6 kW	16.5 Ω (-0/+5%) 4 kW 10 kW	9 Ω (-0/+5%) 8 kW 19 kW
Energy absorption capability 115V ac input 230V ac input	211 J 117 J	381 J 211 J	669 J 370 J
Continuous power output 115V ac input 230V ac input	1.5 kW 3 kW	3.75 kW 7.5 kW	7.5 kW 15 kW

⁽¹⁾ Specification is for nominal voltage. The absolute limits are $\pm 10\%$, or 88...265V rms.

⁽²⁾ The 2098-DSD-030x-xx, -075x-xx, and -150x-xx(230V) drives are limited to one contactor cycles per two minutes.

⁽³⁾ Power initialization requires a short period of inrush current. Dual-element time delay (slow blow) fuses are recommended.

⁽⁴⁾ 400 μ s half wave sine.

ATTENTION



The inrush current-limiting circuitry is limited in the number of power cycles it can withstand within a set period of time. If you exceed these limitations, the circuitry will be damaged.

Page A-4

Add the attention statement (below) to the Ultra3000 (460V) Power Specifications table on page A-4. The table didn't change, however, the warning applies to all Ultra3000 drives.

Ultra3000 Drive (460V) Power Specifications

2098-DSD-HV030x-xx, -HV050x-xx, -HV100x-xx, -HV150x-xx, and -HV220x-xx

Specification	Description				
	2098-DSD-HV030	2098-DSD-HV050	2098-DSD-HV100	2098-DSD-HV150	2098-DSD-HV220
AC Input Voltage ⁽¹⁾⁽²⁾	230...480V rms Three-phase				
AC Input Frequency	47...63 Hz				
Main AC Input Current ⁽³⁾⁽⁴⁾ 460V ac (rms) Nom 460V ac (rms) Max inrush	4 A 6 A	7 A 6 A	14 A 6 A	20 A 6 A	28 A 6 A
Auxiliary AC Input Current 230V ac (rms) Nom 360V ac (rms) Nom 480V ac (rms) Nom 230V ac (0-pk) Max inrush ⁽⁵⁾ 480V ac (0-pk) Max inrush ⁽⁵⁾	0.55 A 0.35 A 0.25 A 47 A 68 A				
Continuous Output Current (0-pk)	7 A	11 A	23 A	34 A	47 A
Intermittent Output Current (0-pk)	14 A	22 A	46 A	68 A	94 A
Bus Capacitance	470 µF		705 µF	940 µF	1880 µF
Internal Shunt Resistance	120 Ω		40 Ω	25 Ω	20 Ω
Shunt On	800V dc				
Shunt Off	750V dc				
Bus Overvoltage	810V dc				
Internal Shunt Continuous power Peak power	100 W 5.3 kW		200 W 16 kW	200 W 25.6 kW	400 W 32 kW
External Shunt Resistance (-0/+5%) Continuous power Peak power	120 Ω 3 kW 5.3 kW		40 Ω 10 kW 16 kW	25 Ω 15 kW 25.6 kW	20 Ω 22 kW 32 kW
Energy Absorption Capability 230V ac input with 230V motor 230V ac input with 460V motor 460V ac input	15 J 129 J 55 J		22 J 194 J 82 J	29 J 259 J 109 J	59 J 517 J 219 J
Continuous Power Output 230V ac input 460V ac input	1.5 kW 3.0 kW	2.5 kW 5.0 kW	5.0 kW 10 kW	7.5 kW 15 kW	11 kW 22 kW

⁽¹⁾ Specification is for nominal voltage. The absolute limits are ±10%, or 207...528V rms.

⁽²⁾ The 2098-DSD-HVxxx-xx drives can be powered with 230-240 V rms in order to be used in conjunction with motors designed for 230V operation. In such cases, the voltage levels used for shunting and DC bus overvoltage limits are adjusted to be compatible with the voltage limit of the motor.

⁽³⁾ The 2098-DSD-HVxxx-xx (460V) drives are limited to three contactor cycles per minute.

⁽⁴⁾ Power initialization requires a short period of inrush current (processor controlled via soft start circuitry). Dual element time delay (slow blow) fuses are recommended (refer to Fuse Specifications on page 6-8).

⁽⁵⁾ 400 µs half wave sine.

ATTENTION



The inrush current-limiting circuitry is limited in the number of power cycles it can withstand within a set period of time. If you exceed these limitations, the circuitry will be damaged.

Page B-2

Replace notes 6 and 7 in the Ultra3000 Interconnect Diagram Notes with the ones shown below. The new versions include information regarding the placement of ac line filters and routing of wires.

Note:	Information:
6	May be used to maintain power to logic section of drive and status LED indicators when main ac input power is removed. A separate ac line source may be used if voltage is between 88-265V ac (rms) on 2098-DSD-xxx (230V drives) or 207-528V ac (rms) on 2098-DSD-HVxxx (460V drives). In this configuration, a separate line filter for logic power may be required.
7	Place the ac (EMC) line filter as close to the drive as possible and do not route very dirty wires in wireway (refer to Establishing Noise Zones, on page 1-13). If routing in wireway is unavoidable, use shielded cable with shields grounded to the drive chassis and filter case. For ac line filter specifications, refer to AC Line Filter Specifications in Appendix A.

Page B-4

Replace the interconnect diagram on page B-4 with the one shown below. The new diagram changes the recommended wiring of input fusing, ac line filter, and contactor.

Figure B.2
Typical Power Wiring of Ultra3000 System
(2098-DSD-030x-xx)

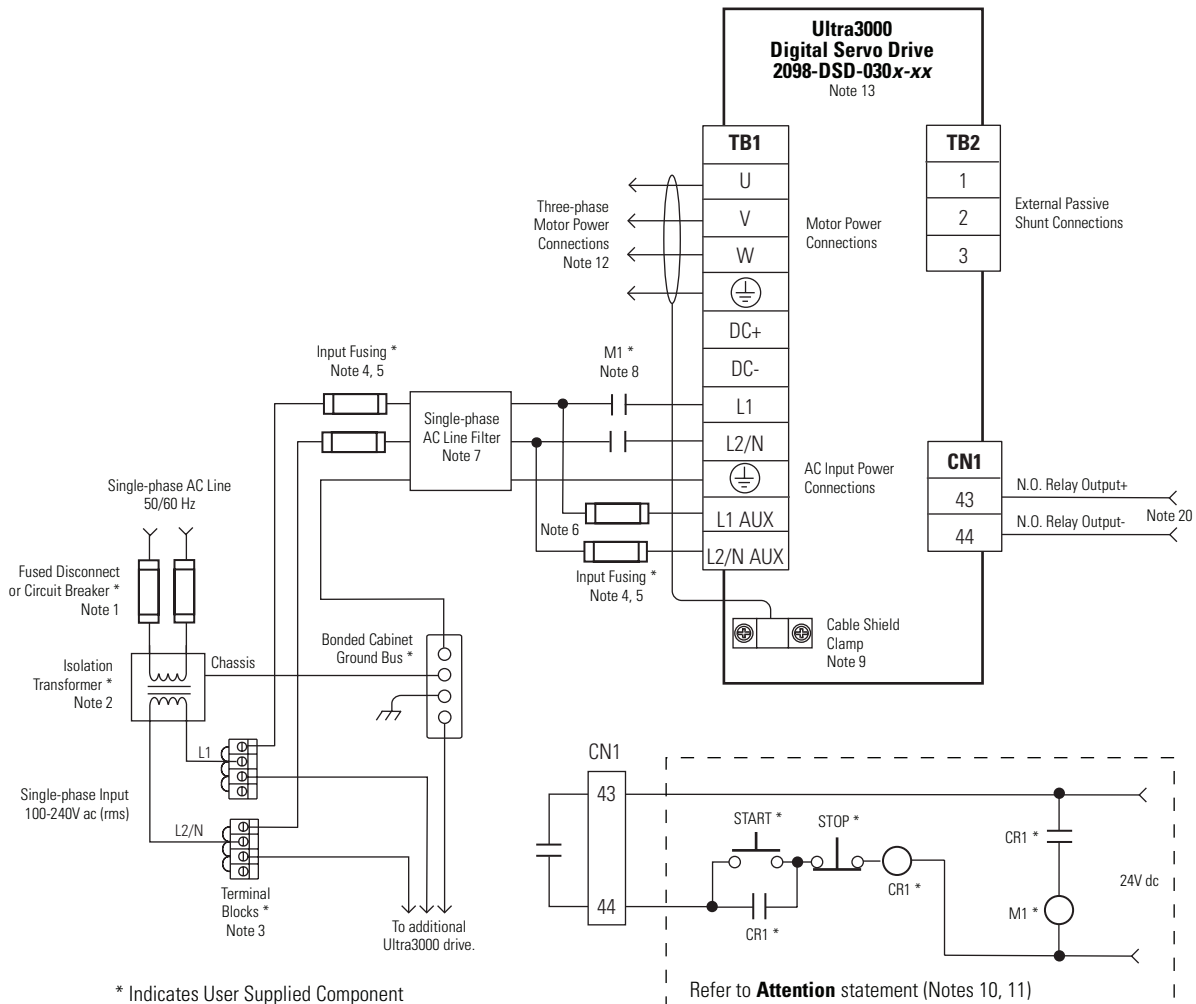

Page B-5

Replace the interconnect diagram on page B-5 with the one shown below. The new diagram changes the recommended wiring of input fusing, ac line filter, and contactor.

Figure B.3
Typical Power Wiring of Ultra3000 System
(2098-DSD-075x-xx and -150x-xx)

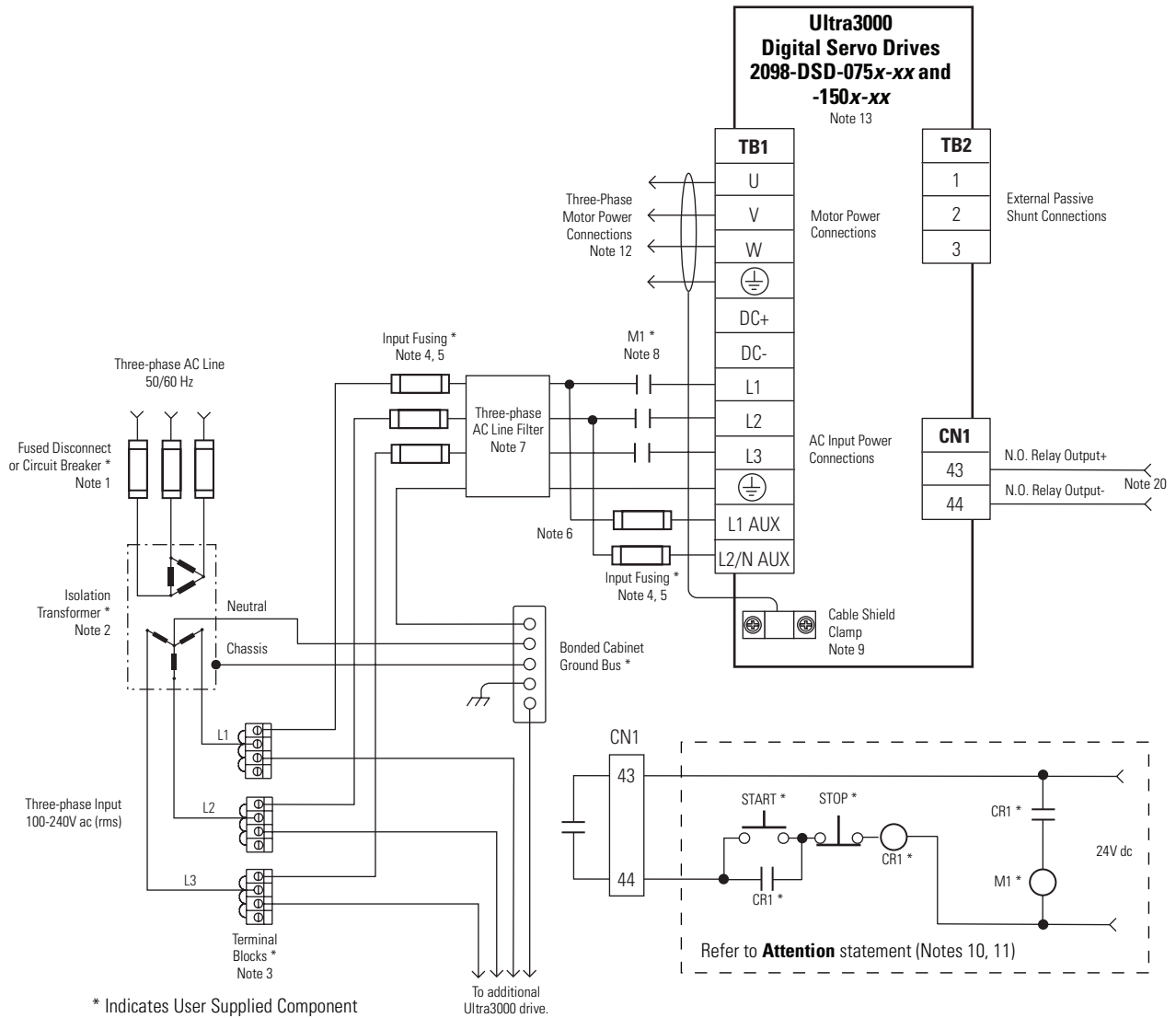

Page B-6

Replace the interconnect diagram on page B-6 with the one shown below. The new diagram changes the recommended wiring of input fusing, ac line filter, and contactor.

Figure B.4
Typical Power Wiring of Ultra3000 System
(2098-DSD-HVxxx-xx and -HVxxxX-xx)

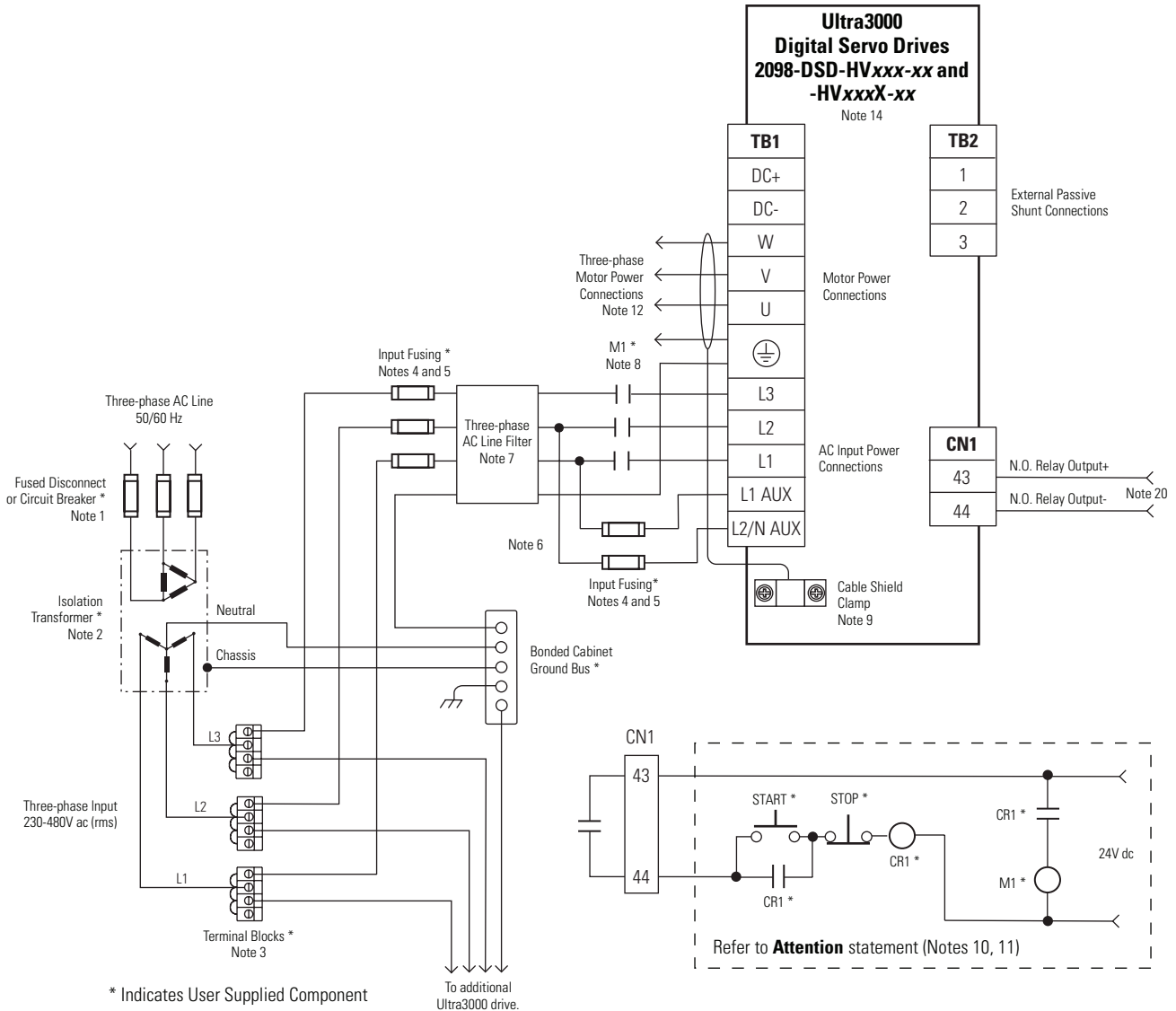

Page B-12

Replace Figure B.12 on page B-12 with the one shown below. The new figure includes MP-Series food grade (MPF), stainless steel (MPS) and low inertia (MPL-A/B15xx and MPL-A/B2xx) motors. Also included is an illustration of grounding the feedback cable shield.

Figure B.12
Ultra3000 Drive to MP-Series (MPL-A/B, MPF-A/B, and MPS-A/B) Motors

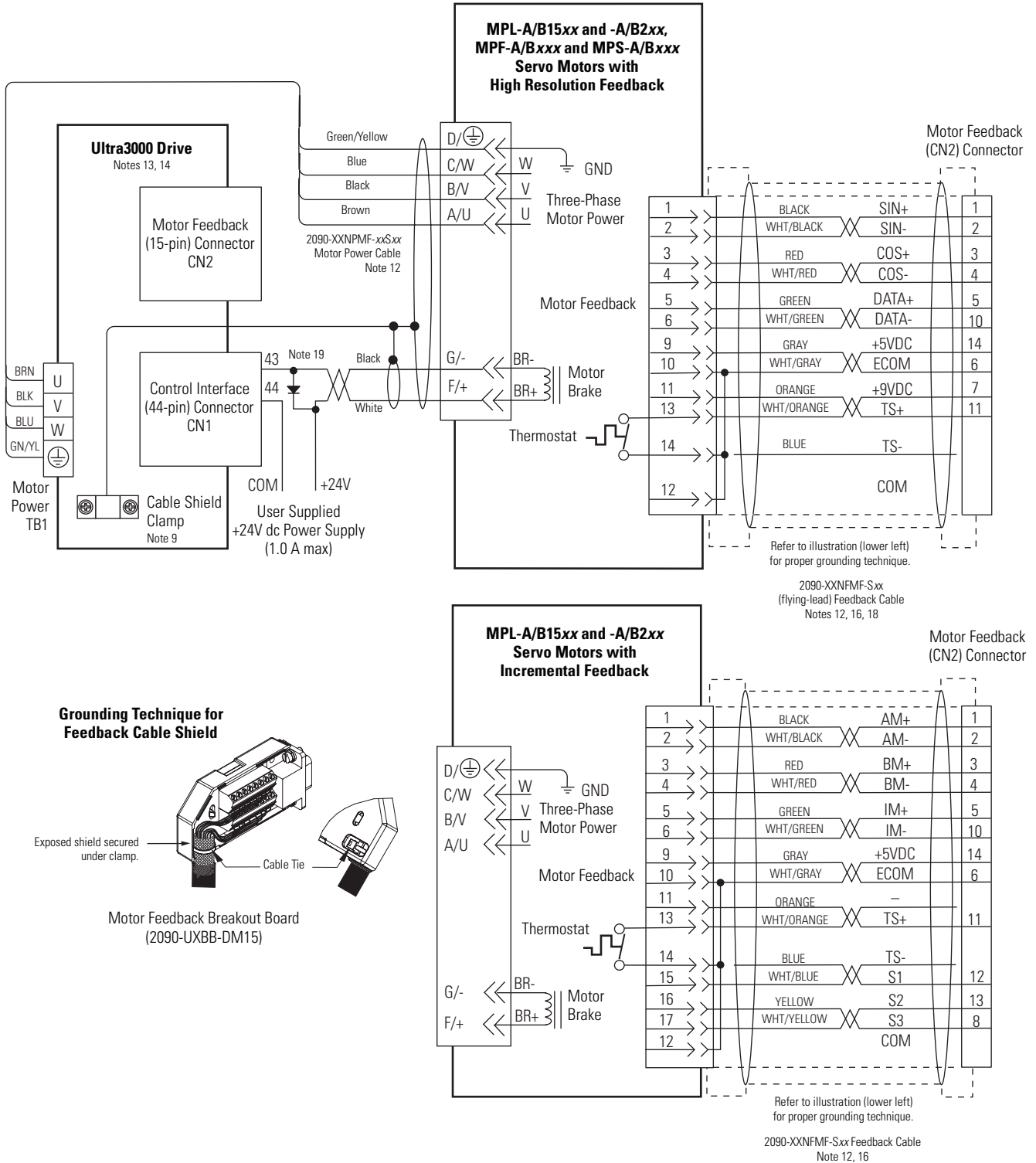

Page B-13

Replace Figure B.13 on page B-13 with the one shown below. The new figure correctly identifies the motor brake-connector pins as A and B. Also included is an illustration of grounding the feedback cable shield.

Figure B.13
Ultra3000 Drive to H- and F-Series (230V) Motors

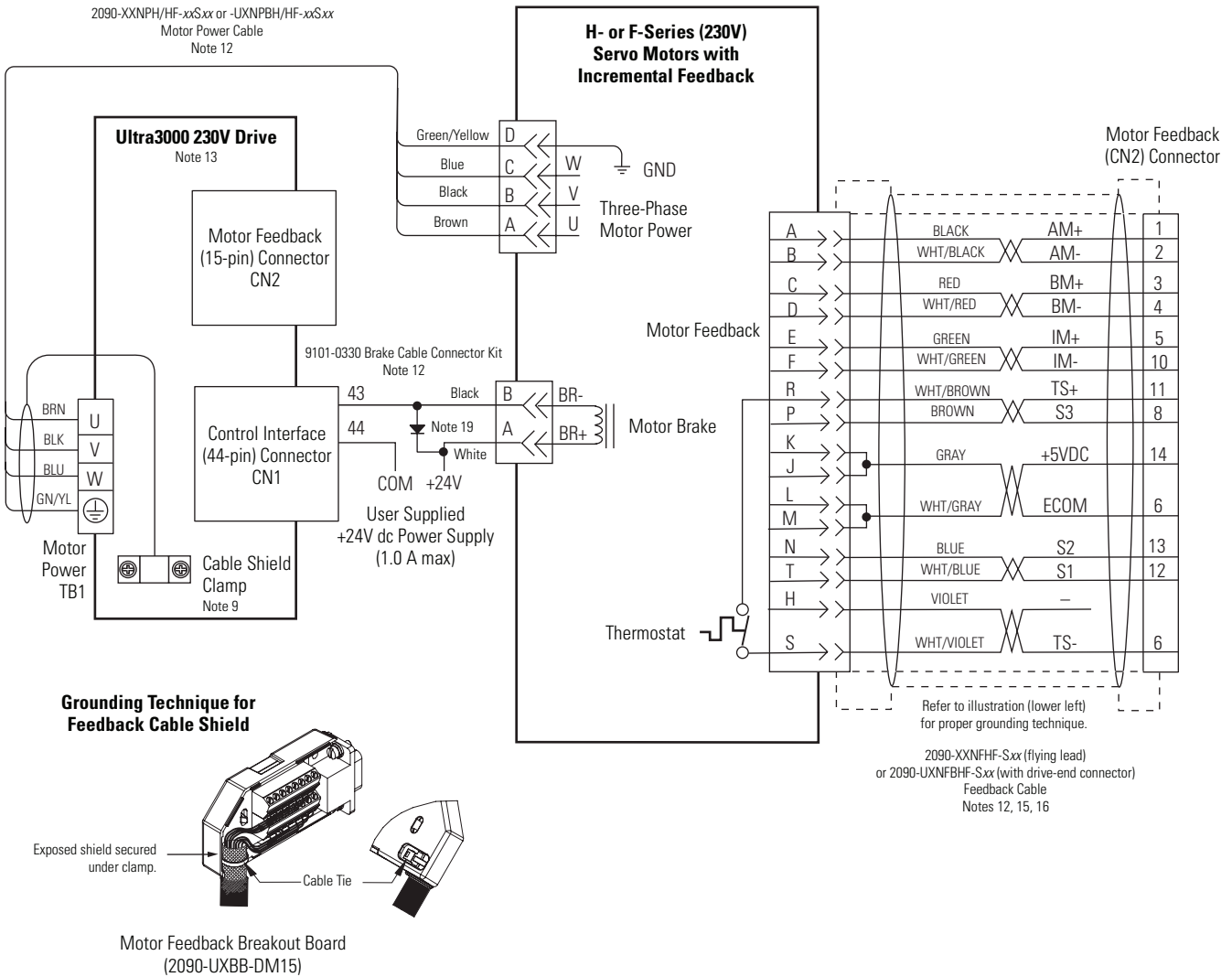

Page B-15

Replace Figure B.15 on page B-15 with the one shown below. The new figure correctly identifies the motor power-cable pins as 1, 2, 3, and 5. Also included is an illustration of grounding the feedback cable shield.

Figure B.15
Ultra3000 Drive to Y-Series (230V) Motors

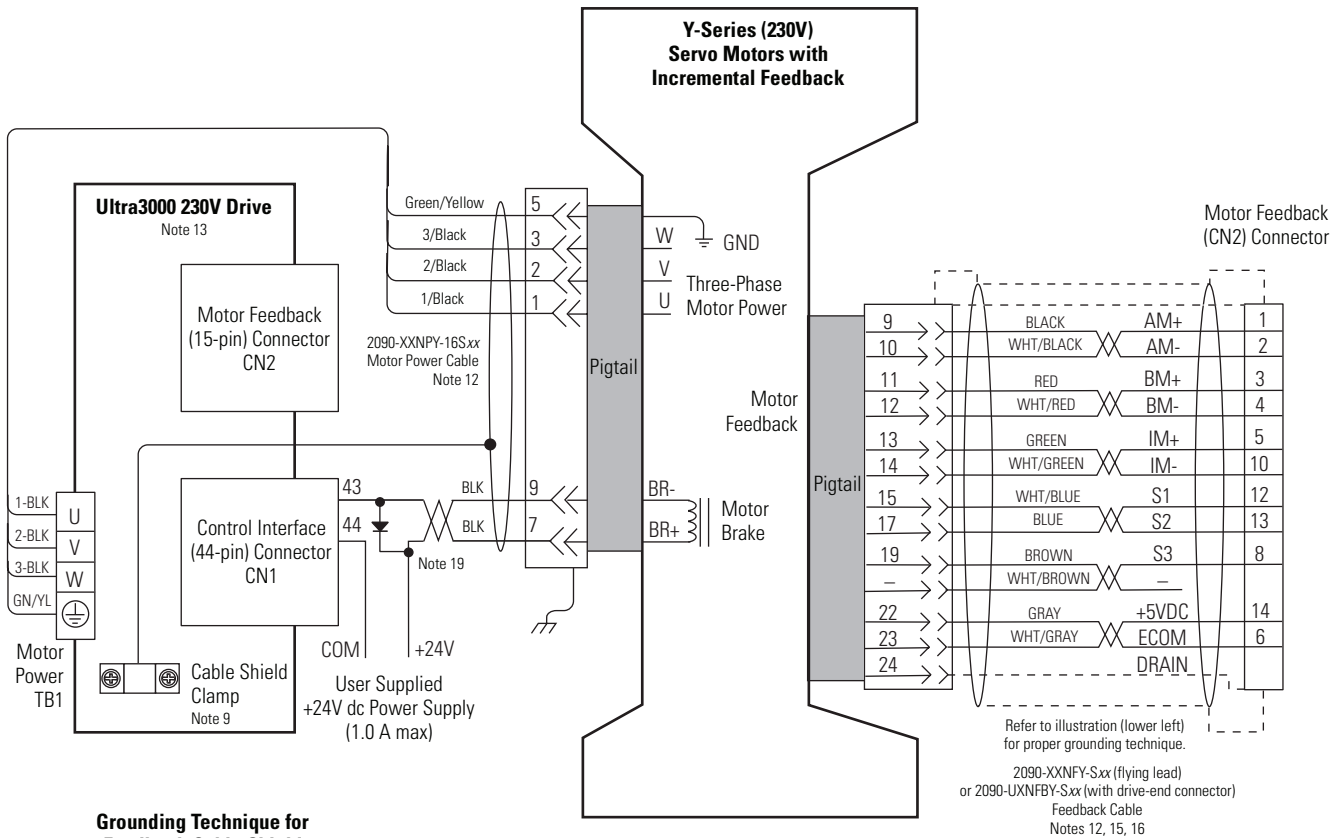

Grounding Technique for Feedback Cable Shield

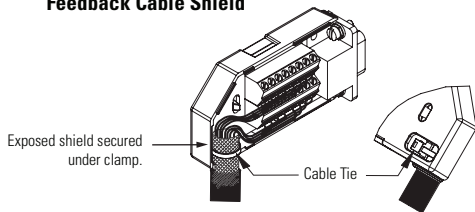

Motor Feedback Breakout Board
(2090-UXBB-DM15)

Replace the table on page B-19 with the one shown below. The new table includes the MPL-x15xx, MPL-x2xx, and TL-Series motors.

Compatible Brake Motors	Coil Current
MPL-x15xx ⁽¹⁾	0.48 A
MPL-x2xx ⁽¹⁾	0.51 A
MPL/MPF/MPS-x310, -x320, -x330 ⁽¹⁾	0.50 A
MPL-x420, -x430, -x4520, -x4530, -x4540 ⁽¹⁾	0.64 A
MPF-x430, -x4530, -x4540 ⁽¹⁾	
MPG-x004 ⁽¹⁾	0.33 A
MPG-x010 ⁽¹⁾	0.45 A
MPG-x025 ⁽¹⁾	
MPG-x050 ⁽¹⁾	0.50 A
MPG-x110 ⁽¹⁾	1.0 A

⁽¹⁾ Applies to 230V and 460V motors.

Compatible Brake Motors	Coil Current
1326AB-B4xxx	0.88 A
F-4030, -4050, and -4075	0.69 A
Y-1002 and -1003	0.26 A
Y-2006 and -2012	0.31 A
Y-3023	0.37 A
TL-A110P-H, -A120P-H, and -A130P-H	0.208 A
TL-A220P-H and -A230P-H	0.375 A
TL-A2530P-H and -A2540P-H	0.396 A
TL-A410P-H	0.746 A

Replace Figure B.19 with the one shown below. The new figure correctly identifies the relay output pins as CN1-43 and CN1-44.

Figure B.19
Example Configuration Controlling a Motor Brake

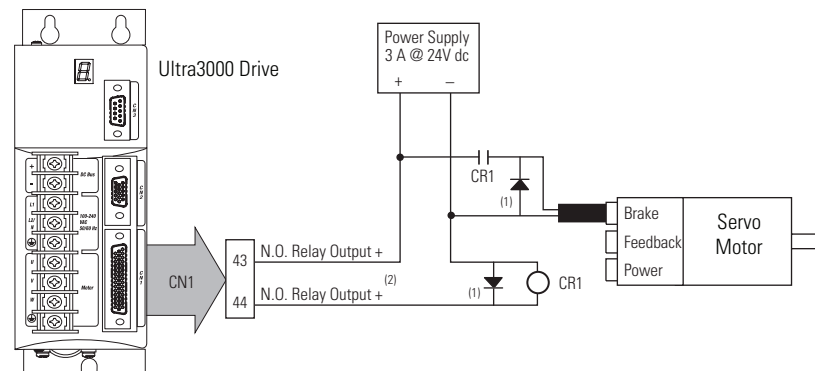

- (1) Flyback diode (1N4004 rated 1.0 A @ 400V dc) or MOV suppresses the collapsing field of the brake coil.
- (2) For non-SERCOS drive, the relay output (CN1-43 and -44) must be configured as a brake.

IMPORTANT Electrical arcing may occur at the relay contacts until the brake power dissipates. A customer-supplied diode or metal oxide varistor (MOV) is recommended to prevent arcing. Use of an MOV can also reduce the time to mechanically engage the brake.

Allen-Bradley, Rockwell Automation, and Ultra3000 are trademarks of Rockwell Automation, Inc. Trademarks not belonging to Rockwell Automation are property of their respective companies.

Power, Control and Information Solutions Headquarters

Americas: Rockwell Automation, 1201 South Second Street, Milwaukee, WI 53204-2496 USA, Tel: (1) 414.382.2000, Fax: (1) 414.382.4444
 Europe/Middle East/Africa: Rockwell Automation, Vorstlaan/Boulevard du Souverain 36, 1170 Brussels, Belgium, Tel: (32) 2 663 0600, Fax: (32) 2 663 0640
 Asia Pacific: Rockwell Automation, Level 14, Core F, Cyberport 3, 100 Cyberport Road, Hong Kong, Tel: (852) 2887 4788, Fax: (852) 2508 1846

Preface	Introduction	P-1
	Who Should Use this Manual	P-1
	Purpose of this Manual	P-1
	Contents of this Manual	P-2
	Product Receiving and Storage Responsibility	P-2
	Related Documentation	P-3
	Conventions Used in this Manual	P-4
	Allen-Bradley Support	P-4
	Local Product Support	P-4
	Technical Product Assistance	P-4
	Comments Regarding this Manual	P-4
	Chapter 1	
Installing Your Ultra3000	Chapter Objectives.	1-1
	Complying with European Union Directives	1-2
	EMC Directive	1-2
	Meeting CE Requirements	1-2
	Low Voltage Directive.	1-3
	Ultra3000 System Component Overview	1-3
	Before Mounting Your System	1-5
	Unpacking Modules	1-5
	System Mounting Requirements.	1-6
	Ventilation Requirements	1-7
	Sizing an Enclosure	1-8
	Transformer Sizing	1-8
	Fuse Sizing.	1-10
	HF Bonding Your System	1-10
	Bonding Modules	1-11
	Bonding Multiple Subpanels	1-12
	Planning Your Panel Layout.	1-12
	Establishing Noise Zones	1-13
	Cable Categories for the Ultra3000.	1-14
	Mounting Guidelines to Reduce Electrical Noise	1-15
	Mounting Your Ultra3000 Drive	1-18
	Chapter 2	
Ultra3000 Connector Data	Chapter Objectives.	2-1
	Understanding Ultra3000 Connectors	2-1
	Ultra3000 Front Panel Connections	2-2
	Ultra3000 (with SERCOS) Front Panel Connections.	2-10
	Ultra3000 (with DeviceNet) Front Panel Connections	2-18
	Understanding Ultra3000 I/O Specifications	2-26
	Digital I/O Power Supply	2-26
	Auxiliary 5V Logic Supply.	2-26
	Digital Inputs	2-28
	Digital Outputs.	2-33
	Analog COMMAND Input	2-37

Analog ILIMIT Input	2-38
Analog Output	2-39
Understanding Motor Encoder Feedback Specifications . . .	2-40
AM, BM, and IM Inputs	2-40
Hall Inputs	2-42
Thermostat Input	2-42
+ Limit and - Limit Inputs	2-43
Encoder Phasing	2-44
Motor Encoder Connection Diagram	2-45
Understanding Motor Feedback Signals and Outputs	2-46
Unbuffered Encoder Outputs	2-46
Incremental Encoder Output	2-47
High Resolution Encoder Output	2-48
Understanding Auxiliary Encoder Feedback Specifications .	2-49
5V Auxiliary Encoder Power Supply	2-51
Understanding the Serial Interface	2-51
Default Serial Interface Settings	2-52
Multiple Axes RS-232 Communications	2-52
Four-Wire RS-485 Connections	2-53
Restoring Drive Communications	2-54

Chapter 3

Connecting Your Ultra3000

Chapter Objectives	3-1
Understanding Basic Wiring Requirements	3-1
Building Your Own Cables	3-2
Routing Power and Signal Wiring	3-2
Determining Your Type of Input Power	3-3
Three-Phase Power Wired to Three-Phase Drives	3-3
Single-Phase Power Wired to Single-Phase Drives	3-5
Three-Phase Power Wired to Single-Phase Drives	3-6
Grounding Your Ultra3000	3-9
Grounding Your System to the Subpanel	3-9
Grounding Multiple Subpanels	3-10
Motor Power Cable Shield Termination	3-10
Power Wiring Requirements	3-13
Connecting Input Power	3-16
Connecting Motor Power and Brakes	3-18
Applying the Motor Cable Shield Clamp	3-18
Wiring Motor Power	3-19
Understanding Motor Brake Connections	3-21
Understanding Shunt Connections	3-22
Understanding Feedback and I/O Cable Connections	3-23
Motor Feedback Connector Pin-outs	3-24
Connecting Your SERCOS Fiber-Optic Cables	3-26
Connecting to a DeviceNet Network	3-29
Connecting Your DeviceNet Cable	3-30

	Chapter 4	
Troubleshooting Status Indicators	Chapter Objectives	4-1
	Safety Precautions	4-2
	General Troubleshooting	4-3
	Error Codes	4-3
	Troubleshooting for SERCOS Drives	4-9
	SERCOS Module Status LED	4-9
	SERCOS Network Status LED	4-9
	Troubleshooting for DeviceNet Drives	4-10
	DeviceNet Module Status LED	4-10
	DeviceNet Network Status LED	4-10
	Appendix A	
Specifications and Dimensions	Chapter Objectives	A-1
	Certifications	A-1
	Ultra3000 Power Specifications	A-2
	Ultra3000 (230V) Power Specifications	A-2
	Ultra3000 (460V) Power Specifications	A-4
	Fuse Specifications	A-5
	Circuit Breaker Specifications	A-6
	Contactor Ratings	A-7
	Power Dissipation Specifications	A-7
	Ultra3000 General Specifications	A-8
	Physical and Environmental Specifications	A-8
	Control Specifications	A-8
	Inputs and Outputs Specifications	A-9
	Communication Specifications	A-9
	Motor Feedback Specifications	A-10
	Auxiliary Feedback Specifications	A-10
	Connector Specifications	A-10
	AC Line Filter Specifications	A-11
	Ultra Family External Shunt Module Specifications	A-12
	Maximum Feedback Cable Lengths	A-13
	Dimensions	A-14
	Ultra3000 (230V) Dimensions	A-14
	Ultra3000 (460V) Dimensions	A-16
	Appendix B	
Interconnect Diagrams	Chapter Objectives	B-1
	Ultra3000 Interconnect Diagram Notes	B-2
	Power Interconnect Diagrams	B-3
	Shunt Module Interconnect Diagrams	B-7
	Active Shunt Module Diagrams	B-7
	Passive Shunt Module Diagrams	B-7
	Ultra3000/Motor Interconnect Diagrams	B-10
	Control String Examples (120V ac)	B-16

Controlling a Brake Example	B-19
Ultra3000 to Logix Cable and Interconnect Diagrams	B-20
Ultra3000 to IMC-S Compact Cable and Interconnect Diagram	B-23

Appendix C

Catalog Numbers and Accessories	Chapter Objectives	C-1
	Ultra3000 Drives	C-2
	Software	C-2
	AC Line Filters	C-3
	External Shunt Kits	C-3
	Cables	C-4
	Motor Power Cables	C-4
	Motor Feedback Cables	C-5
	MP-Series Motor Brake Cable	C-5
	Ultra3000 Interface Cables	C-5
	SERCOS Interface Fiber-Optic Cables	C-6
	Drive End Connector Kits	C-6
	Motor End Connector Kits	C-7
	Breakout Board Kits	C-8
	Breakout Boards	C-8
	Breakout Cables	C-8

Preface

Introduction

Read this preface to familiarize yourself with the rest of the manual. This preface contains the following topics:

- Who Should Use this Manual
- Purpose of this Manual
- Contents of this Manual
- Product Receiving and Storage Responsibility
- Related Documentation
- Conventions Used in this Manual
- Allen-Bradley Support

Who Should Use this Manual

Use this manual for designing, installing, and wiring your UltraTM3000 Digital Servo Drive (DSD). The manual is intended for engineers or technicians directly involved in the installation and wiring of the Ultra3000.

If you do not have a basic understanding of the Ultra3000, contact your local Allen-Bradley representative for information on available training courses before using this product.

Purpose of this Manual

This manual provides the mounting, wiring, and connecting procedures for the Ultra3000 and standard Rockwell Automation/Allen-Bradley motors recommended for use with the Ultra3000.

For power up procedures, troubleshooting tables, and system integration with Ultraware or the ControlLogix[®] and SoftLogix[™] modules/PCI cards (see table below) refer to the *Ultra3000 Digital Servo Drives Integration Manual* (publication 2098-IN005x-EN-P). Manuals are available electronically (as a .pdf) or in hardcopy from www.theautomationbookstore.com.

Interface	ControlLogix Motion Module	SoftLogix PCI Card
SERCOS interface [™]	1756-MxxSE	1784-PM16SE
Analog interface	1756-M02AE	1784-PM02AE

Contents of this Manual

Refer to the following listing for the descriptive contents of this installation manual.

Chapter	Title	Contents
	<i>Preface</i>	Describes the purpose, background, and scope of this manual. Also specifies the audience for whom this manual is intended.
1	<i>Installing Your Ultra3000</i>	Provides mounting information for the Ultra3000.
2	<i>Ultra3000 Connector Data</i>	Provides I/O, encoder, and serial interface connector locations and signal descriptions.
3	<i>Connecting Your Ultra3000</i>	Provides connection and wiring information for the Ultra3000.
4	<i>Troubleshooting Status Indicators</i>	Provides troubleshooting tables that define the Ultra3000 status LED error codes.
Appendix A	<i>Specifications and Dimensions</i>	Provides physical, electrical, environmental, and functional specifications for the Ultra3000.
Appendix B	<i>Interconnect Diagrams</i>	Provides interconnect diagrams for the Ultra3000.
Appendix C	<i>Catalog Numbers and Accessories</i>	Provides catalog numbers and descriptions of the Ultra3000 and related products.

Product Receiving and Storage Responsibility

You, the customer, are responsible for thoroughly inspecting the equipment before accepting the shipment from the freight company. Check the item(s) you receive against your purchase order. If any items are obviously damaged, it is your responsibility to refuse delivery until the freight agent has noted the damage on the freight bill. Should you discover any concealed damage during unpacking, you are responsible for notifying the freight agent. Leave the shipping container intact and request that the freight agent make a visual inspection of the equipment.

Store the product in its shipping container prior to installation. If you are not going to use the equipment for a period of time, store using the following guidelines.

- Use a clean, dry location
- Maintain an ambient temperature range of -40 to 70° C (-40 to 158° F)
- Maintain a relative humidity range of 5% to 95%, non-condensing
- Store it where it cannot be exposed to a corrosive atmosphere
- Store it in a non-construction area

Related Documentation

The following documents contain additional information concerning related Allen-Bradley products. To obtain a copy, contact your local Allen-Bradley office, distributor, or download them from www.theautomationbookstore.com

For:	Read This Document:	Catalog Number:
Information on configuring and troubleshooting your Ultra3000	<i>Ultra3000 Digital Servo Drives Integration Manual</i>	2098-IN005x-EN-P
Ultraware Installation Instructions	<i>Ultraware CD Installation Instructions</i>	2098-IN002x-EN-P
Information on configuring your Ultra3000 using Ultraware	<i>Ultraware User Manual</i>	2098-UM001x-EN-P
Information on communicating with the Ultra3000 using DeviceNet™	<i>Ultra3000 DeviceNet Reference Manual</i>	2098-RM001x-EN-P
Information on attaching Ultra3000 drives to a DeviceNet network	<i>DeviceNet Cable System Planning and Installation Manual</i>	DN-6.7.2
A description and specifications for the Ultra Family including motors and motor accessories	<i>Motion Control Selection Guide</i>	GMC-SG001x-EN-P
Application sizing and configuration information	<i>Motion Book Servo Sizing CD</i> (v4.0 service pack 4 or above)	Motion Book- <i>mmmyy</i>
More detailed information on the use of ControlLogix motion features and application examples	<i>ControlLogix Motion Module Programming Manual</i>	1756-RM086x-EN-P
ControlLogix SERCOS interface module installation instructions	<i>3, 8, or 16 Axis SERCOS interface Module Installation Instructions</i>	1756-IN572x-EN-P
ControlLogix Analog Encoder Servo module installation instructions	<i>Analog Encoder (AE) Servo Module Installation Instructions</i>	1756-IN047x-EN-P
SoftLogix SERCOS interface PCI card installation instructions	<i>16 Axis PCI SERCOS interface Card Installation Instructions</i>	1784-IN041x-EN-P
SoftLogix Analog Encoder PCI card installation instructions	<i>PCI 2 Axis Servo Card Installation Instructions</i>	1784-IN005x-EN-P
The instructions needed to program a motion application	<i>Logix Controller Motion Instruction Set Reference Manual</i>	1756-RM007x-EN-P
Information on configuring and troubleshooting your ControlLogix motion module	<i>ControlLogix Motion Module Setup and Configuration Manual</i>	1756-UM006x-EN-P
Information on configuring and troubleshooting your SoftLogix PCI card	<i>SoftLogix Motion Card Setup and Configuration Manual</i>	1784-UM003x-EN-P
Information on proper handling, installing, testing, and troubleshooting fiber-optic cables	<i>Fiber-Optic Cable Installation and Handling Instructions</i>	2090-IN010x-EN-P
Information, examples, and techniques designed to minimize system failures caused by electrical noise	<i>System Design for Control of Electrical Noise Reference Manual</i>	GMC-RM001x-EN-P
For declarations of conformity (DoC) currently available from Rockwell Automation	Rockwell Automation Product Certification website	www.ab.com/certification/ce/docs
An article on wire sizes and types for grounding electrical equipment	<i>National Electrical Code</i>	Published by the National Fire Protection Association of Boston, MA.
A glossary of industrial automation terms and abbreviations	<i>Allen-Bradley Industrial Automation Glossary</i>	AG-7.1

Conventions Used in this Manual

The following conventions are used throughout this manual.

- Bulleted lists such as this one provide information, not procedural steps
- Numbered lists provide sequential steps or hierarchical information
- Words that you type or select appear in bold
- When we refer you to another location, the section or chapter name appears in italics
- Abbreviations for the Ultra3000 drives, shown in the table below, are used throughout this manual

Ultra3000 Drive	Abbreviation
Ultra3000 with SERCOS interface	Ultra3000-SE
Ultra3000 with DeviceNet interface	Ultra3000-DN

Allen-Bradley Support

Allen-Bradley offers support services worldwide, with over 75 Sales/Support Offices, 512 authorized Distributors and 260 authorized Systems Integrators located throughout the United States alone, plus Allen-Bradley representatives in every major country in the world.

Local Product Support

Contact your local Allen-Bradley representative for:

- Sales and order support
- Product technical training
- Warranty support
- Support service agreements

Technical Product Assistance

If you need technical assistance, contact your local Allen-Bradley representative or Rockwell Automation Technical Support at (440) 646-5800 / www.ab.com/support. Please have the catalog numbers of your products available when you call.

Comments Regarding this Manual

To offer comments regarding the contents of this manual, go to www.ab.com/manuals/gmc and download the Motion Control Problem Report form. Mail or fax your comments to the address/fax number given on the form.

Installing Your Ultra3000

Chapter Objectives

This chapter provides system installation guidelines and procedures for mounting your Ultra3000. This chapter covers the following topics:

- Complying with European Union Directives
- Ultra3000 System Component Overview
- Before Mounting Your System
- HF Bonding Your System
- Planning Your Panel Layout
- Mounting Your Ultra3000 Drive

ATTENTION

The following information is a guideline for proper installation. The National Electrical Code and any other governing regional or local codes overrule this information. The Allen-Bradley Company cannot assume responsibility for the compliance or the noncompliance with any code, national, local or otherwise, for the proper installation of this system or associated equipment. If you ignore codes during installation, hazard of personal injury and/or equipment damage exists.

Complying with European Union Directives

If this product is installed within the European Union or EEC regions and has the CE mark, the following regulations apply.

Note: Declarations of Conformity (DOCs) to European Union Directives are available on-line at www.ab.com/certification/ce/docs. The web site is the authoritative source for verifying compliance and suitability for use of this and other Rockwell Automation/Allen-Bradley products.

EMC Directive

This unit is tested to meet Council Directive 89/336/EEC Electromagnetic Compatibility (EMC) using a technical construction file and the following standards, in whole or in part:

- EN 50081-2 EMC - Emission Standard, Part 2 - Industrial Environment
- EN 50082-2 EMC - Immunity Standard, Part 2 - Industrial Environment
- EN 61800-3 - Adjustable Speed Electrical Power Drive Systems, Part 3 - EMC Product Standard including specific test methods

The product described in this manual is intended for use in an industrial environment.

Meeting CE Requirements

To meet CE requirements the following components are required:

- Install an AC line filter (2090-UXLF-xxx or -HVxxx) between the AC power source and the drive input, and as close to the drive as possible (refer to *Appendix C* for available AC line filters). The supply must be grounded for the filter to operate properly.
- Connect auxiliary input power (if required) from the load side of the AC line filter to the drive.
- Use 2090 series motor power and feedback cables and terminate the motor power cable shields to the chassis clamp provided (refer to *Chapter 3* for wiring instructions).
- When installing the Ultra3000 system inside an enclosure, run input power wiring (grounded to the enclosure) in conduit outside of the enclosure.
- Separate signal and power cables as shown in *Planning Your Panel Layout* of this chapter.

Low Voltage Directive

These units are tested to meet Council Directive 73/23/EEC Low Voltage Directive. The EN 60204-1 Safety of Machinery-Electrical Equipment of Machines, *Part 1-Specification for General Requirements* standard applies in whole or in part. Additionally, the standard EN 50178 *Electronic Equipment for use in Power Installations* applies in whole or in part.

Refer to *Appendix B* for interconnect information.

Ultra3000 System Component Overview

This section provides an overview of the Ultra3000 system components and a typical installation.

Ultra3000 System Component	Catalog Numbers	Description
Ultra3000 Drives	2098-DSD-xxx and -xxxX	Ultra3000 and Ultra3000 with indexing available with 500W, 1, 2, 3, 7.5 and 15 kW continuous output and 230V input power.
	2098-DSD-HVxxx, and -HVxxxX	Ultra3000 and Ultra3000 with indexing available with 3, 5, 10, 15, and 22 kW continuous output and 460V input power.
Ultra3000-SE SERCOS interface Drives	2098-DSD-xxx-SE	Ultra3000 with SERCOS interface available with 500W, 1, 2, 3, 7.5 and 15 kW continuous output and 230V input power.
	2098-DSD-HVxxx-SE	Ultra3000 with SERCOS interface available with 3, 5, 10, 15, and 22 kW continuous output and 460V input power.
Ultra3000-DN DeviceNet Drives	2098-DSD-xxx-DN and -xxxX-DN	Ultra3000 with DeviceNet and Ultra3000 with indexing DeviceNet available with 500W, 1, 2, 3, 7.5 and 15 kW continuous output with 230V input power.
	2098-DSD-HVxxx-DN and -HVxxxX-DN	Ultra3000 with DeviceNet and Ultra3000 with indexing DeviceNet available with 3, 5, 10, 15, and 22 kW continuous output with 460V input power.
ControlLogix/SoftLogix Platforms	1756-MxxSE module 1784-PM16SE PCI card	The SERCOS interface module/PCI card serves as a link between the ControlLogix/SoftLogix platform and Ultra3000 system. The communication link uses the IEC 61491 Serial Real-time COmmunication System (SERCOS) protocol over a fiber-optic cable.
RSLogix™ 5000 software	9324-RLD300ENE	RSLogix 5000 provides support for programming, commissioning, and maintaining the Logix family of controllers.
Ultraware Software	2098-UWCPRG	The Ultra3000 Analog and DeviceNet drives are configured using Ultraware software.
Servo Motors	MP-Series, 1326AB, F-, H-, N-, and Y-Series	The MP-Series (Low Inertia, Integrated Gear, and Food Grade) 230 and 460V, 1326AB (M2L/S2L) 460V, and F-, H-, N-, and Y-Series 230V motors are available for use with the Ultra3000 drives.
Cables	Motor Power, Feedback, and Brake cables	Motor power, feedback, and brake cables include integral molded, bayonet style, quick connect/quick-release connectors at the motor. Power and brake cables have flying leads on the drive end and straight connectors that connect to servo motors. Standard feedback cables have angled connectors (45°) on the drive end and straight connectors that connect to servo motors.
	Fiber-Optic cables	SERCOS fiber-optic cables are available in enclosure only, PVC, nylon, and glass with connectors at both ends.
AC Line Filters	2090-UXLF-xxx	AC line filters with 6, 10, 23, 32, 36, and 50A are available for Ultra3000 (230V) drive systems.
	2090-UXLF-HVxxx	AC line filters with 23, 30, and 50A are available for Ultra3000 (460V) drive systems.
External Shunt Modules	2090-UCSR-xxxx, 9101-1183, and 2090-SRxxx-xx	External shunt modules are available when the Ultra3000 internal shunt capability is exceeded.

Note: Refer to *Appendix C* for a complete list of catalog numbers for the Ultra3000 system components listed above.

The typical Ultra3000 system installation includes the following, as shown in the figures below.

Figure 1.1
Ultra3000-SE (SERCOS) Digital Servo Drive System Overview

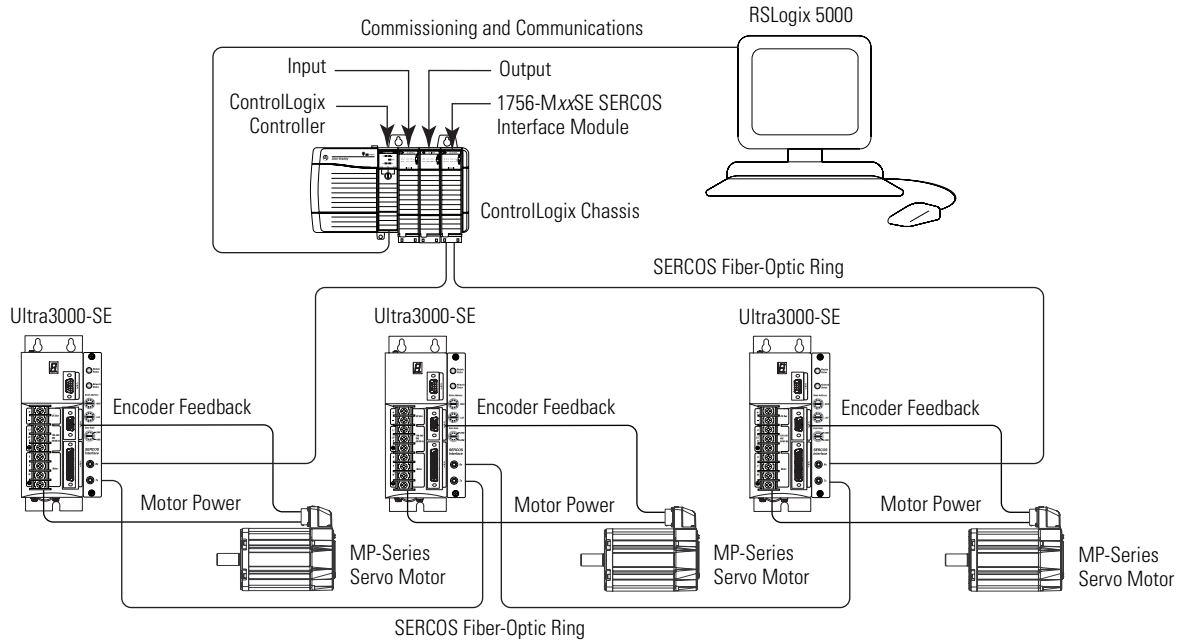

Figure 1.2
Ultra3000 Digital Servo Drive System Overview

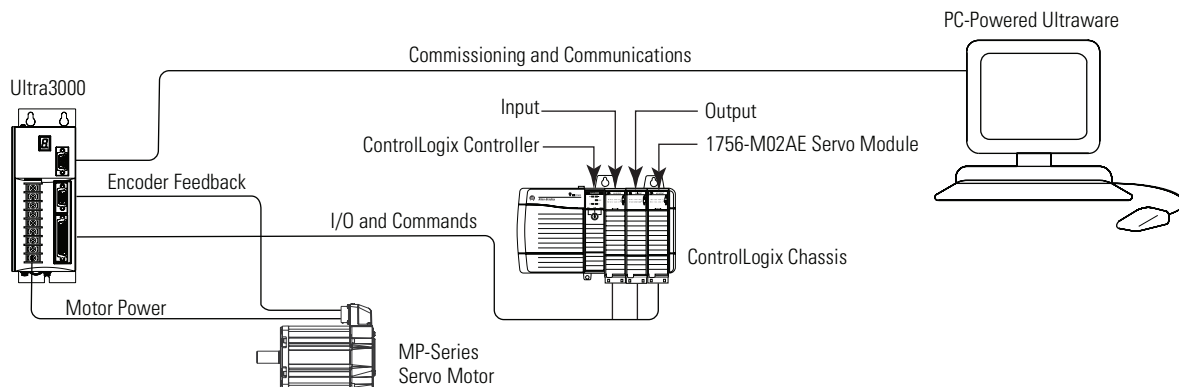
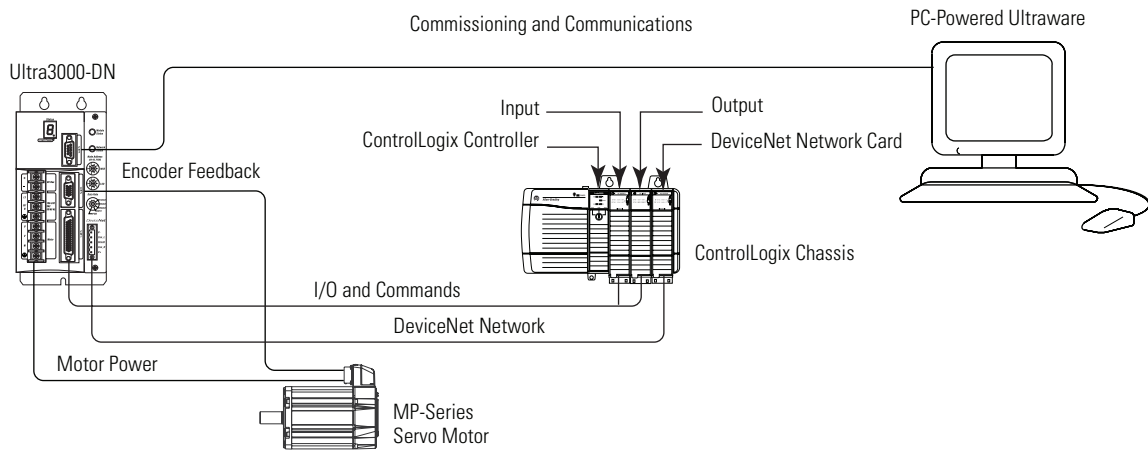

Figure 1.3
Ultra3000-DN (DeviceNet) Digital Servo Drive System Overview



Before Mounting Your System

Before you mount your Ultra3000 system make sure you understand the following:

- how to unpack the system
- the minimum mounting requirements

Unpacking Modules

Each Ultra3000 ships with the following:

- One Ultra3000 drive
- One installation manual (publication 2098-IN003x-EN-P)

Remove all packing material, wedges, and braces from within and around the components. After unpacking, check the item(s) name plate catalog number against the purchase order.

System Mounting Requirements

There are several things that you need to take into account when preparing to mount the Ultra3000:

- The Ultra3000 must be enclosed in a grounded conductive enclosure offering protection as defined in standard EN 60529 (IEC 529) to IP22 such that they are not accessible to an operator or unskilled person, in order to comply with UL[®] and CE requirements. A NEMA 4X enclosure exceeds these requirements providing protection to IP66.
- The ambient temperature of the location in which you will install the Ultra3000 must not exceed 55° C (131° F).
- You must install the Ultra3000 vertically on the panel (refer to Figure 1.4 for mounting orientation).
- You must install the panel on a flat, rigid, vertical surface that won't be subjected to shock, vibration, moisture, oil mist, dust, or corrosive vapors.
- You need to maintain minimum clearances (refer to Figure 1.4) for proper airflow, easy module access, and proper cable bend radius.
- The Ultra3000 can operate at elevations to 1000 m (3280 ft) without derating, however, the continuous current rating must be de-rated by 3% for each additional 300 m (984 ft) up to 3000 m (9842 ft). Consult your local Allen-Bradley representative prior to operating above 3000 m (9842 ft).

ATTENTION

Plan the installation of your system so that you can perform all cutting, drilling, tapping, and welding with the system removed from the enclosure. Because the system is of the open type construction, be careful to keep any metal debris from falling into it. Metal debris or other foreign matter can become lodged in the circuitry, which can result in damage to components.

Refer to *Appendix A* for mounting dimensions, power dissipation, and environmental specifications for the Ultra3000.

Ventilation Requirements

This section provides information to assist you in sizing your cabinet and locating your Ultra3000 drive(s) inside the cabinet.

Figure 1.4
Minimum Clearance Requirements

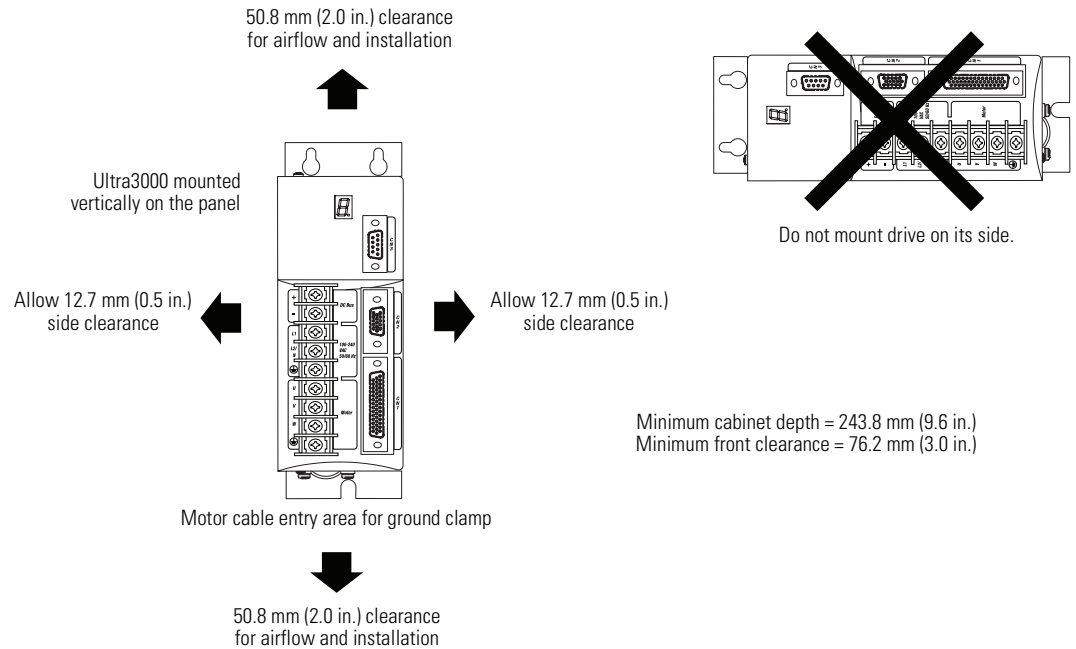

IMPORTANT

If the cabinet is ventilated, use filtered or conditioned air to prevent the accumulation of dust and dirt on electronic components. The air should be free of oil, corrosives, or electrically conductive contaminants.

Refer to *Appendix A* for Ultra3000 power dissipation specifications.

Sizing an Enclosure

As an additional aid in sizing an enclosure, with no active method of heat dissipation, either of the following approximate equations can be used:

Metric	Standard English
$A = \frac{0.38Q}{1.8T - 1.1}$	$A = \frac{4.08Q}{T - 1.1}$
Where T is temperature difference between inside air and outside ambient (°C), Q is heat generated in enclosure (Watts), and A is enclosure surface area (m ²). The exterior surface of all six sides of an enclosure is calculated as	Where T is temperature difference between inside air and outside ambient (°F), Q is heat generated in enclosure (Watts), and A is enclosure surface area (ft ²). The exterior surface of all six sides of an enclosure is calculated as
$A = 2dw + 2dh + 2wh$	$A = (2dw + 2dh + 2wh) / 144$
Where d (depth), w (width), and h (height) are in meters.	Where d (depth), w (width), and h (height) are in inches.

Transformer Sizing

The Ultra3000 does not require isolation transformers. However, a transformer may be required to match the voltage requirements of the controller to the available service. To size a transformer for the main AC power inputs, the power output (KVA) of each axis must be known. This can be derived by calculating the horsepower for each axis and converting that horsepower into units of watts. If you are supplying power to more than one motor and an Ultra3000, simply add the kW ratings together from each calculation to get a system kW total.

IMPORTANT

If using an autotransformer, ensure that the phase to neutral/ground voltages do not exceed the input voltage ratings of the drive.

Definitions:

kW = power or real power

KVA = apparent power

Transformer KVA rating = (Sum of average output power of each axis) x 2.0.

IMPORTANT

If you are using the Rockwell Automation/Allen-Bradley system sizing program, the average speed and average torque data has already been calculated and can be used in the above equation. If you are not sure of the exact speed and torque in your application, another approach is to look at the speed/torque curve for your Ultra3000/motor combination and use the values for the worst case continuous speed and torque.

IMPORTANT

Calculations are multiplied by a factor to compensate for the power and loss elements within a power system. A factor of 2.0 is used with a single phase system and a factor of 1.5 is used with a three phase system. This factor should minimize the effects of the secondary line voltage sagging in the transformer during peak current periods.

Example: sizing a transformer to the voltage requirements of an 2098-DSD-020 and MPL-A320P motor:

$$KVA = \frac{Speed(RPM) \times Torque(lb-in)}{63,025} \times \frac{746Watts}{HP} \times \frac{KVA}{1000Watts} \times 2.0$$

$$KVA = \frac{(5,000(RPM)) \times 17.7(lb-in)}{42,250}$$

$$Transformer\ Size = 2.1\ KVA$$

The speed/torque curve information for 230V motors is based upon an Ultra3000 input voltage of 230V ac. For a 115V ac input voltage, the maximum speed can be reduced up to one half.

Fuse Sizing

In the United States, the National Electric Code (NEC) specifies that fuses must be selected based on the motor full load amperage (FLA). The typical fuse size should be 300% of the motor FLA for non-time delay fuses (and time-delay class CC fuses) or 175% of motor FLA for time delay fuses. If these ratings are not high enough for starting currents, the NEC allows non-time delay fuses (and time-delay class CC fuses) to be sized up to 400% of the motor FLA and time-delay fuses to be sized up to 225% of the motor FLA.

In most cases, fuses selected to match the drive input current rating will meet the NEC requirements and provide the full drive capabilities. Dual element, time delay (slow acting) fuses should be used to avoid nuisance trips during the inrush current of power initialization. Refer to the section *Ultra3000 Power Specifications* in *Appendix A* for input current and inrush current specifications.

The Ultra3000 utilizes solid state motor short circuit protection rated as shown in the table below.

Drive Models:	Input Power Type	Short Circuit Current Rating with No Fuse Restrictions:	Short Circuit Current Rating with Fuse Restrictions:
2098-DSD-xxx-xx or xxxX-xx	Input Power and Auxiliary Input Power	Suitable for use on a circuit capable of delivering not more than 5000 rms symmetrical amperes, 240V maximum.	Suitable for use on a circuit capable of delivering not more than 200,000 rms symmetrical amperes, 240V maximum, when protected by high interrupting capacity, current limiting fuses meeting UL 198C (Class CC, G, J, L, R, T).
2098-DSD-HVxxx-xx or HVxxxX-xx		Suitable for use on a circuit capable of delivering not more than 5000 rms symmetrical amperes, 480V maximum.	Suitable for use on a circuit capable of delivering not more than 200,000 rms symmetrical amperes, 480V maximum, when protected by high interrupting capacity, current limiting fuses meeting UL 198C (Class CC, G, J, L, R, T).

Wiring to the auxiliary power terminals (L1 AUX and L2/N AUX) of the drive should be 2.5 mm² (14 AWG) minimum and fusing for the auxiliary power should be selected to properly protect the wire. For example, if 60° C (140° F) wire is used, the fuse should not exceed 8A. If 75° C (167° F) wire is used, the fuse should not exceed 13A. Refer to *Fuse Specifications* in *Appendix A* for fuse examples.

HF Bonding Your System

Bonding is the practice of connecting metal chassis, assemblies, frames, shields and enclosures to reduce the effects of electromagnetic interference (EMI). For more information on the concept of high-frequency (HF) bonding, the ground plane principle, and electrical noise reduction, refer to the *System Design for Control of Electrical Noise Reference Manual* (publication GMC-RM001x-EN-P).

Bonding Modules

Unless specified, most paints are not conductive and they act as insulators. To achieve a good bond between modules and the subpanel, surfaces need to be paint-free or plated. Bonding metal surfaces creates a low-impedance exit path for high-frequency energy.

IMPORTANT

To improve the bond between the drive and subpanel, construct your subpanel out of zinc plated (paint-free) steel.

Improper bonding blocks that direct exit path and allows high-frequency energy to travel elsewhere in the cabinet. Excessive high-frequency energy can effect the operation of other microprocessor controlled equipment. The illustrations that follow (refer to Figure 1.5) show details of recommended bonding practices for painted panels, enclosures, and mounting brackets.

Figure 1.5
Recommended Bonding Practices

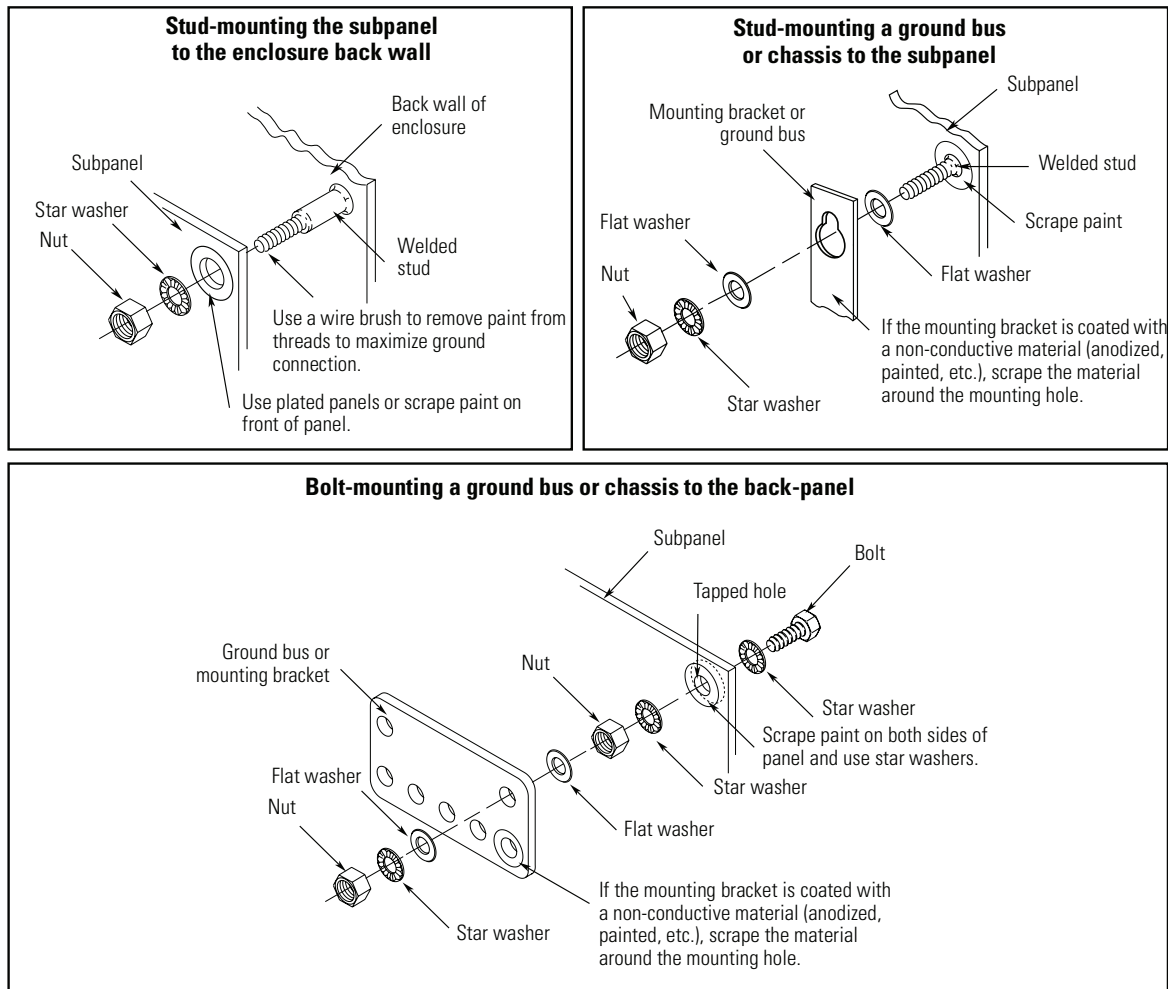

Bonding Multiple Subpanels

Bonding multiple subpanels creates a common low impedance exit path for the high frequency energy inside the cabinet. Subpanels that are not bonded together may not share a common low impedance path. This difference in impedance may affect networks and other devices that span multiple panels. Refer to the figure below for recommended bonding practices.

Figure 1.6
Multiple Subpanels and Cabinet

Recommended:

Bond the top and bottom of each subpanel to the cabinet using 25.4 mm (1.0 in.) by 6.35 mm (0.25 in.) wire braid.

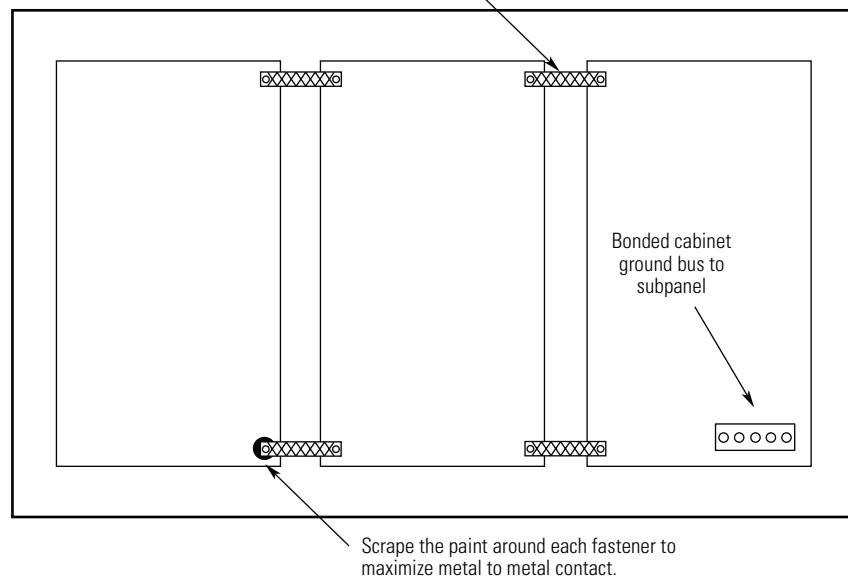

Planning Your Panel Layout

This section outlines the practices which minimize the possibility of noise-related failures as they apply specifically to Ultra3000 installations. For more information on the concept of electrical noise reduction, refer to *System Design for Control of Electrical Noise* (publication GMC-RM001x-EN-P).

Establishing Noise Zones

Observe the following guidelines when laying out your panel (refer to Figure 1.7 for zone locations).

- The clean zone (C) is above and beneath the Ultra3000 and includes CN1, CN2, CN3, and the DC filter (grey wireways).
- The dirty zone (D) is left of the Ultra3000 (black wireways) and includes the circuit breakers, transformer, AC line filter, contactors, 24V dc power supply, and motor power cables.
- The very dirty zone (VD) is limited to where the AC line (EMC) filter AC output jumpers over to the Ultra3000. Shielded cable is required only if the very dirty cables enter a wireway.
- The SERCOS fiber-optic cables are immune to electrical noise.

Figure 1.7
Establishing Noise Zones

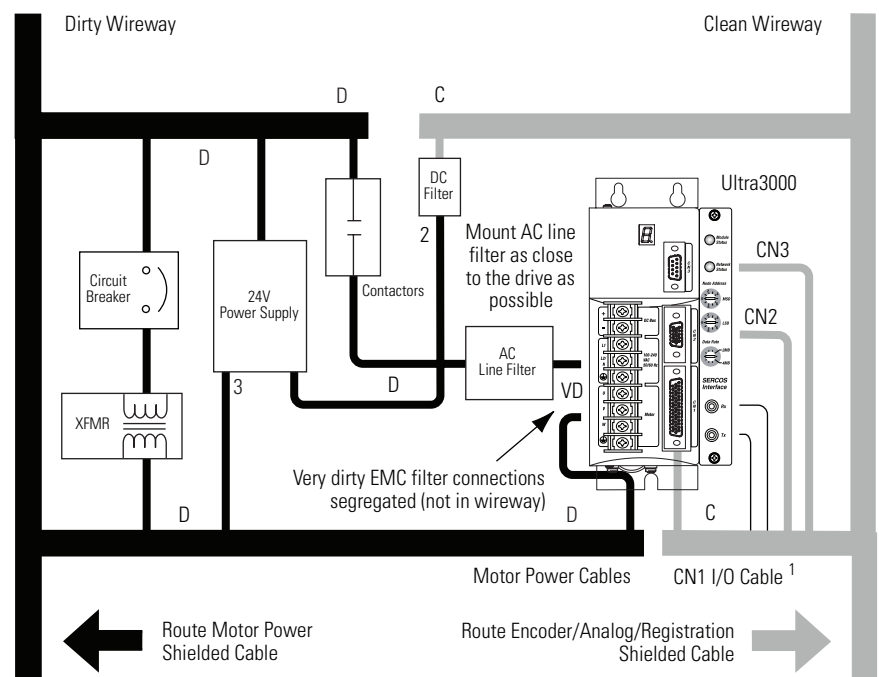

¹ If I/O cable contains (dirty) relay wires, route cable with motor power wires in dirty wireway.

² This is a clean 24V dc available for CN1 I/O power supply. The 24V enters the clean wireway and exits to the right.

³ This is a dirty 24V dc available for motor brakes and contactors. The 24V enters the dirty wireway and exits to the left.

Observe the following guidelines when installing your 1756-MxxSE SERCOS interface module (refer to Figure 1.8 for zone locations).

- The clean zone (C) is beneath the less noisy modules (I/O, analog, encoder, registration, etc. (grey wireway).
- The dirty zone (D) is above and below the power supply and noisy modules (black wireway).
- The SERCOS fiber-optic cables are immune to electrical noise.

Figure 1.8
Establishing Noise Zones (ControlLogix)

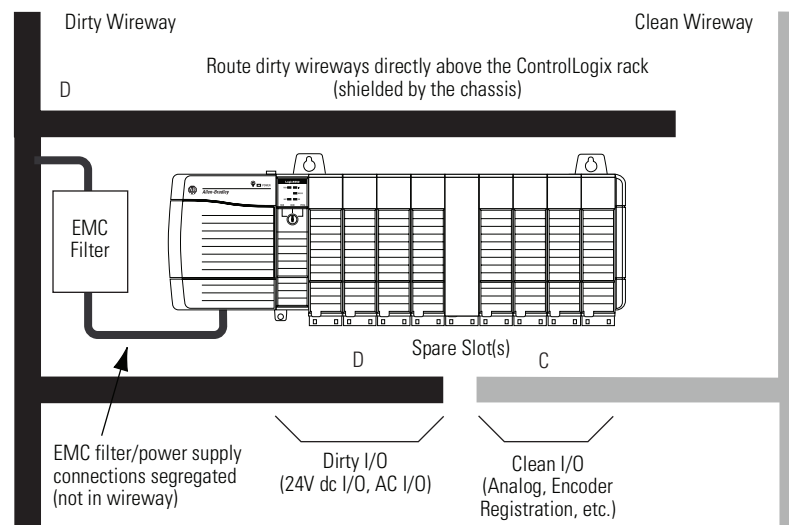

Cable Categories for the Ultra3000

The table below indicates the zoning requirements of cables connecting to the Ultra3000.

Wire/Cable	Connector	Zone			Method	
		Very Dirty	Dirty	Clean	Ferrite Sleeve	Shielded Cable
DC-/DC+	TB1	X				
L1, L2, L3 (shielded cable)			X			X
L1, L2, L3 (unshielded cable)		X				
U, V, W (motor power)			X			X
Registration Wiring	CN1			X		X
Other 24V Wiring	CN1		X			
Motor Feedback	CN2			X		X
Serial Communications	CN3			X		X
Fiber-Optic	Rx and Tx	No Restrictions				

The table below indicates the zoning requirements of cables connecting to the External Shunt Resistor Kit.

Wire/Cable	Connector	Zone			Method	
		Very Dirty	Dirty	Clean	Ferrite Sleeve	Shielded Cable
Shunt Connections (shielded option)	TB2		X			X
Shunt Connections (unshielded option)		X				
Fan (if present)	N/A		X			

Mounting Guidelines to Reduce Electrical Noise

When mounting an AC line (EMC) filter or external shunt resistor refer to the sections below for guidelines designed to reduce system failures caused by excessive electrical noise.

ATTENTION



High voltage exists in AC line filters. The filter must be grounded properly before applying power. Filter capacitors retain high voltages after power removal. Before handling the equipment, voltages should be measured to determine safe levels. Failure to observe this precaution could result in personal injury.

AC Line Filters

Observe the following guidelines when mounting your AC line (EMC) filter (refer to Figure 1.7 for an example).

- Mount the AC line filter and bonded cabinet ground bus on the same panel as the Ultra3000, and as close to the Ultra3000 as possible.
- Good HF bonding to the panel is critical. For painted panels, refer to Figure 1.5.
- Segregate input and output wiring as far as possible.

IMPORTANT

CE test certification applies only to AC line filter and single drive. Multiple drive loads may perform satisfactorily, but the user takes legal responsibility.

External Shunt Resistor

Observe the following guidelines when mounting your external shunt resistor (refer to Figure 1.9 and for an example).

- Mount circuit components and wiring in the very dirty zone or in an external shielded enclosure. Run shunt power and fan wiring inside metal conduit to minimize the effects of EMI and RFI.
- Mount resistors (other than metal-clad) in a shielded and ventilated enclosure outside the cabinet.
- Keep unshielded wiring as short as possible. Keep shunt wiring as flat to the cabinet as possible.

Figure 1.9
External Shunt Resistor Outside the Enclosure

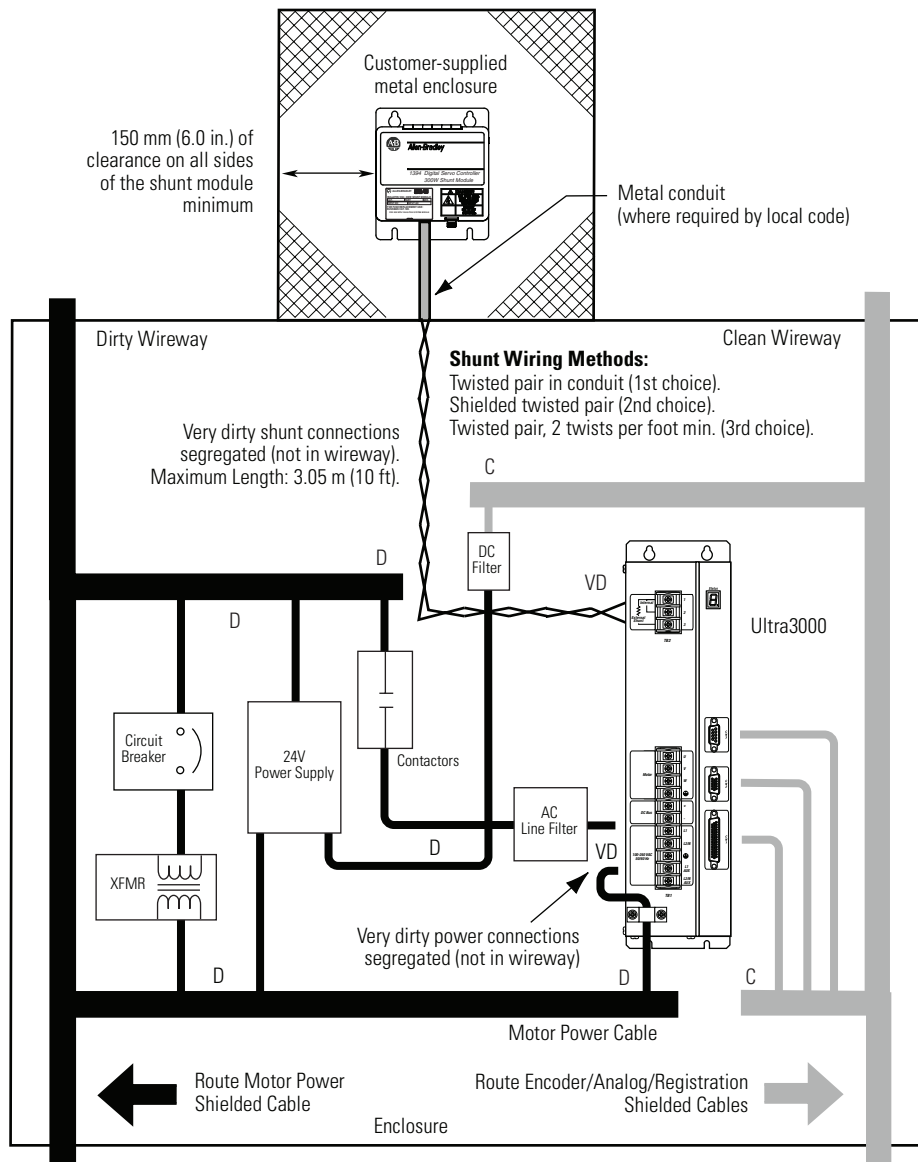

When mounting your shunt module inside the enclosure, follow these additional guidelines (refer to Figure 1.10 and for an example).

- Metal-clad modules can be mounted anywhere in the dirty zone, but as close to the Ultra3000 as possible.
- Shunt power wires can be run with motor power cables.
- Keep unshielded wiring as short as possible. Keep shunt wiring as flat to the cabinet as possible.
- Separate shunt power cables from other sensitive, low voltage signal cables.

Figure 1.10
External Shunt Resistor Inside the Enclosure

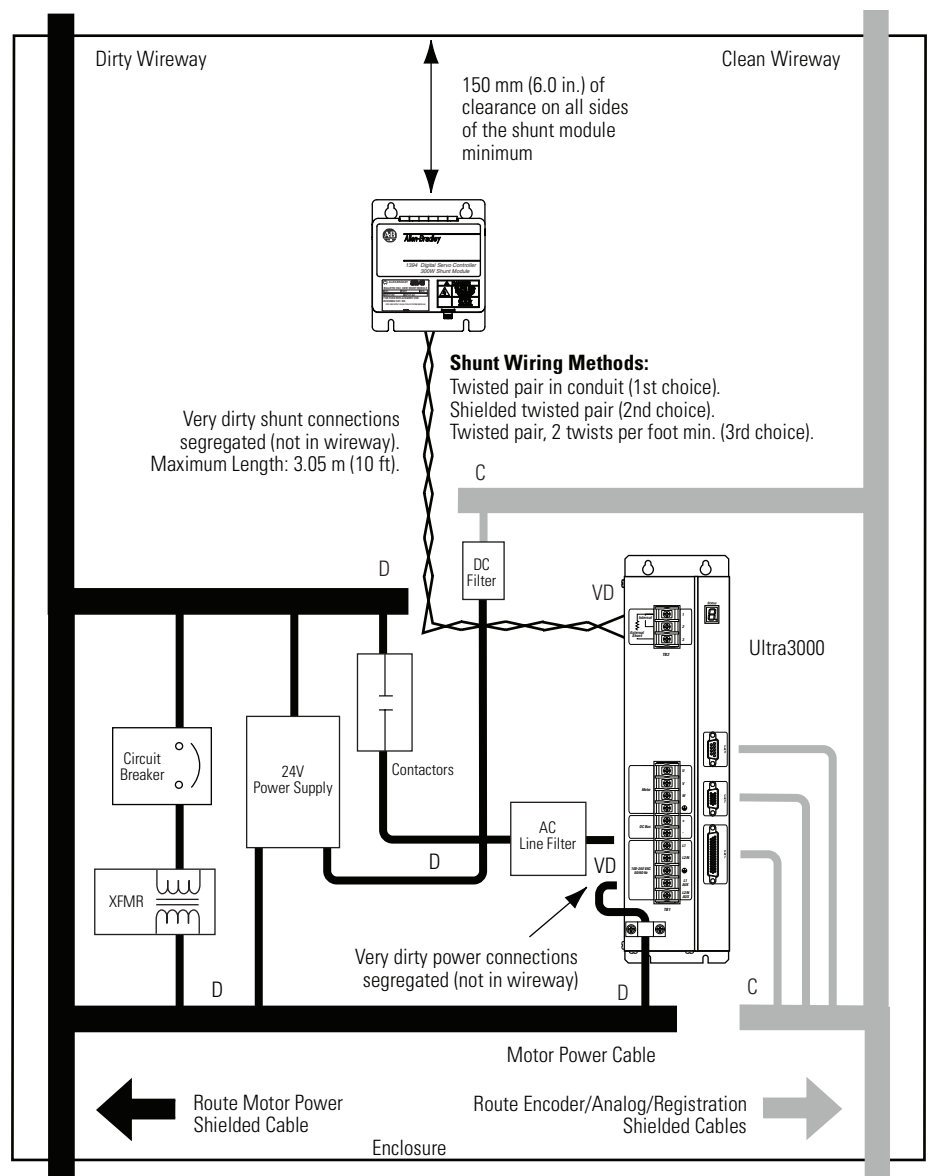

Mounting Your Ultra3000 Drive

The procedures in this section assume you have prepared your panel and understand how to bond your system. For installation instructions regarding other equipment and accessories, refer to the instructions that came with each of the accessories for their specific requirements.

ATTENTION

This drive contains ESD (Electrostatic Discharge) sensitive parts and assemblies. You are required to follow static control precautions when you install, test, service, or repair this assembly. If you do not follow ESD control procedures, components can be damaged. If you are not familiar with static control procedures, refer to Allen-Bradley publication 8000-4.5.2, *Guarding Against Electrostatic Damage* or any other applicable ESD Protection Handbook.

To mount your Ultra3000 drive:

1. Layout the position for the Ultra3000 and accessories in the enclosure (refer to *Establishing Noise Zones* for panel layout recommendations). Mounting hole dimensions for the Ultra3000 are shown in *Appendix A*.
2. Attach the Ultra3000 to the cabinet, first using the upper mounting slots of the drive and then the lower. The recommended mounting hardware is M5 metric (1/4-20) or #10 MS bolts. Observe bonding techniques as described in *HF Bonding Your System*.

IMPORTANT

To improve the bond between the Ultra3000 and subpanel, construct your subpanel out of zinc plated (paint-free) steel.

3. Tighten all mounting fasteners.

Ultra3000 Connector Data

Chapter Objectives

This chapter provides I/O, encoder, and serial interface connector locations and signal descriptions for your Ultra3000. This chapter includes:

- Understanding Ultra3000 Connectors
- Understanding Ultra3000 I/O Specifications
- Understanding Motor Encoder Feedback Specifications
- Understanding Auxiliary Encoder Feedback Specifications
- Understanding the Serial Interface

Switch and LED locations are shown, however for switch and LED configuration, refer to the *Ultra3000 Digital Servo Drives Integration Manual* (publication 2098-IN005x-EN-P).

Understanding Ultra3000 Connectors

The following table provides a brief description of the Ultra3000 front panel connectors and describes the connector type.

Designator	Description	Connector
CN1	User Input/Output	44-pin high-density D-shell
CN2	Motor Feedback	15-pin high-density D-shell
CN3	Serial Port	9-pin standard D-shell
TB	DC bus, Motor and AC power	9-position screw style barrier terminal strip (2098-DSD-005x-xx, -010x-xx, and -020x-xx)
TB1	DC bus, Motor, AC power, and auxiliary AC power	11- or 12-position screw style barrier terminal strip (2098-DSD-030x-xx, -075x-xx, -150x-xx, HVxxx-xx, and HVxxxX-xx)
TB2	Shunt	3-position screw style barrier terminal strip (2098-DSD-030x-xx, -075x-xx, -150x-xx, HVxxx-xx, and HVxxxX-xx)

All signal connections on the Ultra3000 use commonly available D-shell type connectors.

For connector pin-outs and the location of connectors, switches, and status LEDs on:	Refer to:
2098-DSD-xxx and -HVxxx Ultra3000 drives	Figures 2.1-2.4 and the tables that follow on pages 2-2 through 2-9.
2098-DSD-xxx and -HVxxx Ultra3000 drives with SERCOS interface	Figures 2.5-2.8 and the tables that follow on pages 2-10 through 2-17.
2098-DSD-xxx and -HVxxx Ultra3000 drives with DeviceNet interface	Figures 2.9-2.12 and the tables that follow on pages 2-18 through 2-25.

Ultra3000 Front Panel Connections

Use the figure below to locate the front panel connections on the Ultra3000 230V drives (500W, 1 kW, and 2 kW).

Figure 2.1
Ultra3000 Front Panel Connections
for 2098-DSD-005, -005X, -010, -010X, -020, and -020X

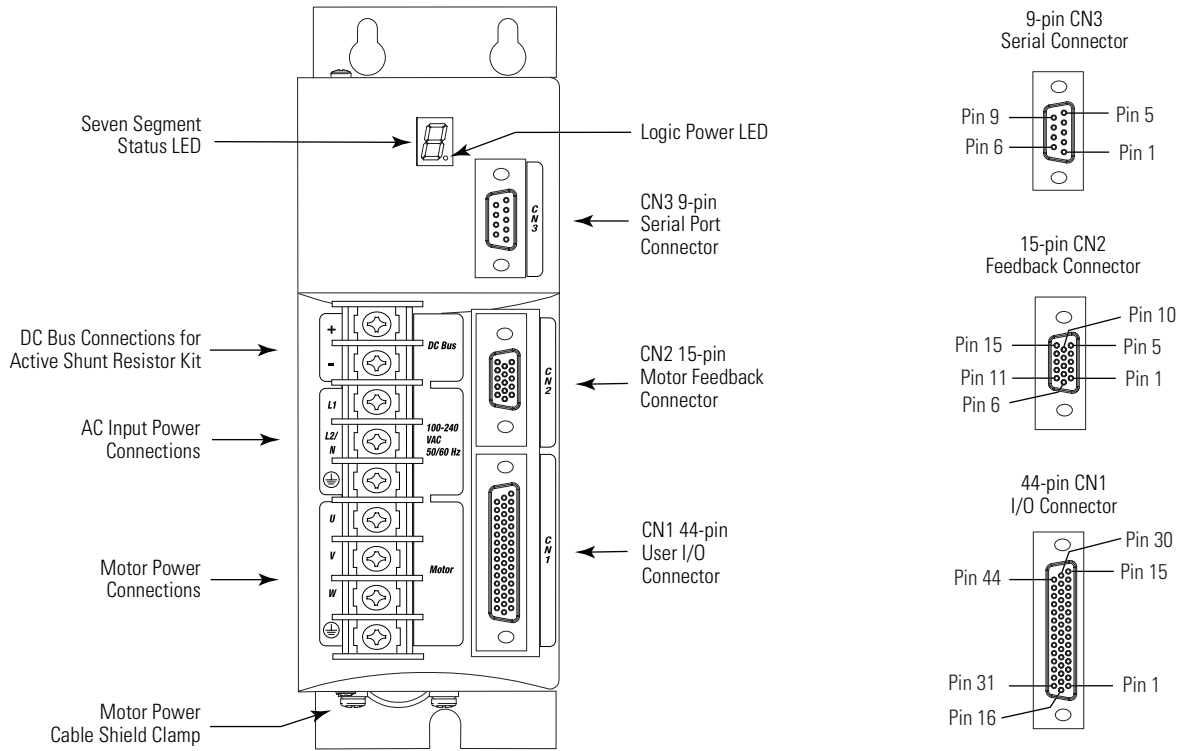

Serial Port Connector

The following table provides the signal descriptions and pin-outs for the CN3 serial port (9-pin) connector.

CN3 Pin	Description	Signal
1	RS-422/RS-485 Input+	RCV+
2	RS-232 Input	RCV
3	RS-232 Output	XMT
4	RS-422/RS-485 Output+	XMT+
5	Common	COM
6	Reserved	—
7	RS-422/RS-485 Input-	RCV-
8	RS-422/RS-485 Output-	XMT-
9	Reserved	—

I/O Connector

The following table provides the signal descriptions and pin-outs for the CN1 I/O (44-pin) connector.

CN1 Pin	Description	Signal
1	Auxiliary Encoder Power Out (+5V)	EPWR
2	Common	ECOM
3	Auxiliary Logic Power In (+5V)	AUXPWR
4	Auxiliary A+/Step+/CW+	AX+
5	Auxiliary A-/Step-/CW-	AX-
6	Auxiliary B+/Dir+/CCW+	BX+
7	Auxiliary B-/Dir-/CCW-	BX-
8	Auxiliary Encoder Ch I+	IX+
9	Auxiliary Encoder Ch I-	IX-
10	Unbuffered Motor Encoder Ch A+	AM+
11	Unbuffered Motor Encoder Ch A-	AM-
12	Unbuffered Motor Encoder Ch B+	BM+
13	Unbuffered Motor Encoder Ch B-	BM-
14	Unbuffered Motor Encoder Ch I+	IM+
15	Unbuffered Motor Encoder Ch I-	IM-
16	Buffered Motor Encoder Ch A+	AMOUT+
17	Buffered Motor Encoder Ch A-	AMOUT-
18	Buffered Motor Encoder Ch B+	BMOUT+
19	Buffered Motor Encoder Ch B-	BMOUT-
20	Buffered Motor Encoder Ch I+	IMOUT+
21	Buffered Motor Encoder Ch I-	IMOUT-
22	Common	ACOM

CN1 Pin	Description	Signal
23	Programmable Analog Output	AOUT
24	Analog Current Limit Input	ILIMIT
25	Command +	COMMAND+
26	Command -	COMMAND-
27	I/O Common	IOCOM
28	I/O Common	IOCOM
29	I/O Power	IOPWR
30	I/O Power	IOPWR
31	Digital Input 1	INPUT1
32	Digital Input 2	INPUT2
33	Digital Input 3	INPUT3
34	Digital Input 4	INPUT4
35	Digital Input 5	INPUT5
36	Digital Input 6	INPUT6
37	Digital Input 7	INPUT7
38	Digital Input 8	INPUT8
39	Digital Output 1	OUTPUT1
40	Digital Output 2	OUTPUT2
41	Digital Output 3	OUTPUT3
42	Digital Output 4	OUTPUT4
43	Normally Open Relay Output+	RELAY+
44	Normally Open Relay Output-	RELAY-

Motor Encoder Connector

The following table provides the signal descriptions and pin-outs for the CN2 motor encoder (15-pin) connector.

CN2 Pin	Description	Signal
1	Channel A+/Sine Differential Input+	AM+
2	Channel A-/Sine Differential Input-	AM-
3	Channel B+/Cosine Differential Input+	BM+
4	Channel B-/Cosine Differential Input-	BM-
5	Channel I+/Index Pulse+	IM+
6	Common	ECOM
7	Reserved	-
8	Commutation Channel S3	S3

CN2 Pin	Description	Signal
9	Positive Overtravel Limit	+LIMIT
10	Channel I-/Index Pulse-	IM-
11	Thermostat	TS
12	Commutation Channel S1	S1
13	Commutation Channel S2	S2
14	Encoder Power (+5V)	EPWR_5V
15	Negative Overtravel Limit	-LIMIT

Use the figure below to locate the front panel connections on the Ultra3000 230V drives (3 kW).

Figure 2.2
Ultra3000 Front Panel Connections for 2098-DSD-030 and -030X

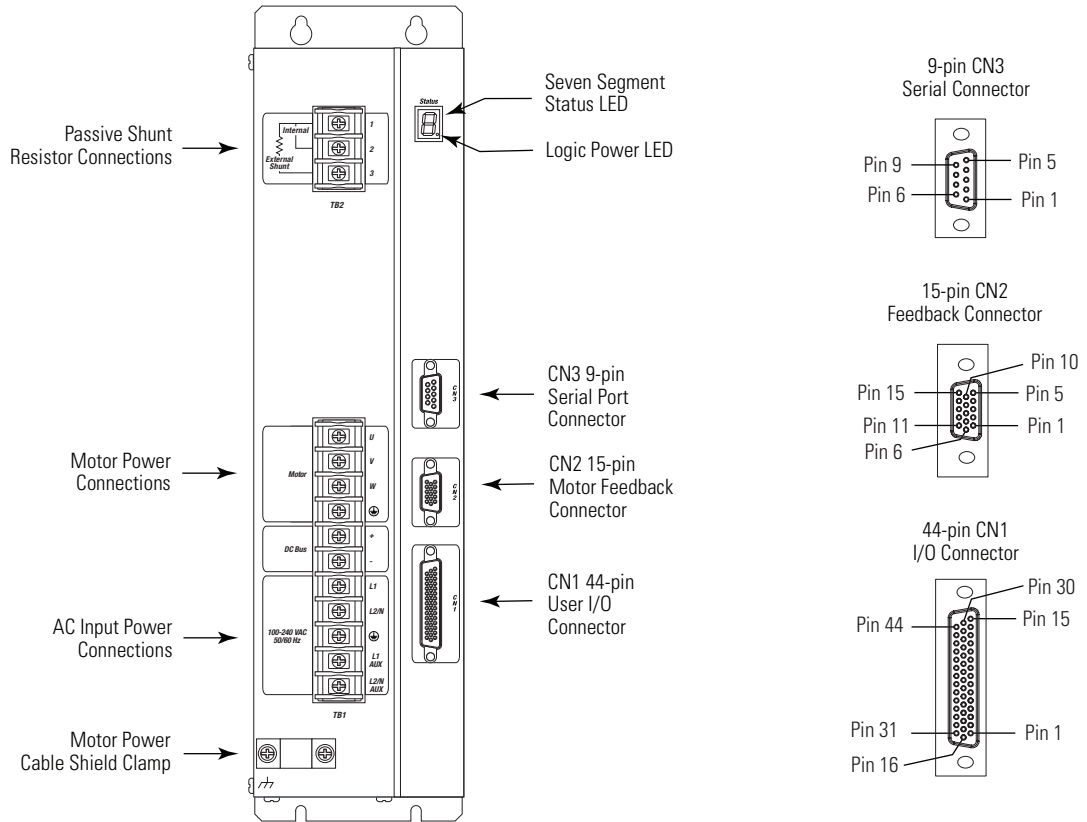

Serial Port Connector

The following table provides the signal descriptions and pin-outs for the CN3 serial port (9-pin) connector.

CN3 Pin	Description	Signal
1	RS-422/RS-485 Input+	RCV+
2	RS-232 Input	RCV
3	RS-232 Output	XMT
4	RS-422/RS-485 Output+	XMT+
5	Common	COM
6	Reserved	—
7	RS-422/RS-485 Input-	RCV-
8	RS-422/RS-485 Output-	XMT-
9	Reserved	—

I/O Connector

The following table provides the signal descriptions and pin-outs for the CN1 I/O (44-pin) connector.

CN1 Pin	Description	Signal
1	Auxiliary Encoder Power Out (+5V)	EPWR
2	Common	ECOM
3	Reserved	–
4	Auxiliary A+/Step+/CW+	AX+
5	Auxiliary A-/Step-/CW-	AX-
6	Auxiliary B+/Dir+/CCW+	BX+
7	Auxiliary B-/Dir-/CCW-	BX-
8	Auxiliary Encoder Ch I+	IX+
9	Auxiliary Encoder Ch I-	IX-
10	Unbuffered Motor Encoder Ch A+	AM+
11	Unbuffered Motor Encoder Ch A-	AM-
12	Unbuffered Motor Encoder Ch B+	BM+
13	Unbuffered Motor Encoder Ch B-	BM-
14	Unbuffered Motor Encoder Ch I+	IM+
15	Unbuffered Motor Encoder Ch I-	IM-
16	Buffered Motor Encoder Ch A+	AMOUT+
17	Buffered Motor Encoder Ch A-	AMOUT-
18	Buffered Motor Encoder Ch B+	BMOUT+
19	Buffered Motor Encoder Ch B-	BMOUT-
20	Buffered Motor Encoder Ch I+	IMOUT+
21	Buffered Motor Encoder Ch I-	IMOUT-
22	Common	ACOM

CN1 Pin	Description	Signal
23	Programmable Analog Output	AOUT
24	Analog Current Limit Input	ILIMIT
25	Command +	COMMAND+
26	Command -	COMMAND-
27	I/O Common	IOCOM
28	I/O Common	IOCOM
29	I/O Power	IOPWR
30	I/O Power	IOPWR
31	Digital Input 1	INPUT1
32	Digital Input 2	INPUT2
33	Digital Input 3	INPUT3
34	Digital Input 4	INPUT4
35	Digital Input 5	INPUT5
36	Digital Input 6	INPUT6
37	Digital Input 7	INPUT7
38	Digital Input 8	INPUT8
39	Digital Output 1	OUTPUT1
40	Digital Output 2	OUTPUT2
41	Digital Output 3	OUTPUT3
42	Digital Output 4	OUTPUT4
43	Normally Open Relay Output+	RELAY+
44	Normally Open Relay Output-	RELAY-

Motor Encoder Connector

The following table provides the signal descriptions and pin-outs for the CN2 motor encoder (15-pin) connector.

CN2 Pin	Description	Signal
1	Channel A+/Sine Differential Input+	AM+
2	Channel A-/Sine Differential Input-	AM-
3	Channel B+/Cosine Differential Input+	BM+
4	Channel B-/Cosine Differential Input-	BM-
5	Channel I+/Index Pulse+	IM+
6	Common	ECOM
7	Encoder Power (+9V)	EPWR_9V
8	Commutation Channel S3	S3

CN2 Pin	Description	Signal
9	Positive Overtravel Limit	+LIMIT
10	Channel I-/Index Pulse-	IM-
11	Thermostat	TS
12	Commutation Channel S1	S1
13	Commutation Channel S2	S2
14	Encoder Power (+5V)	EPWR_5V
15	Negative Overtravel Limit	-LIMIT

Use the figure below to locate the front panel connections on the Ultra3000 230V (7.5 and 15 kW).

Figure 2.3
Ultra3000 Front Panel Connections for 2098-DSD-075, -075X, -150, and -150X

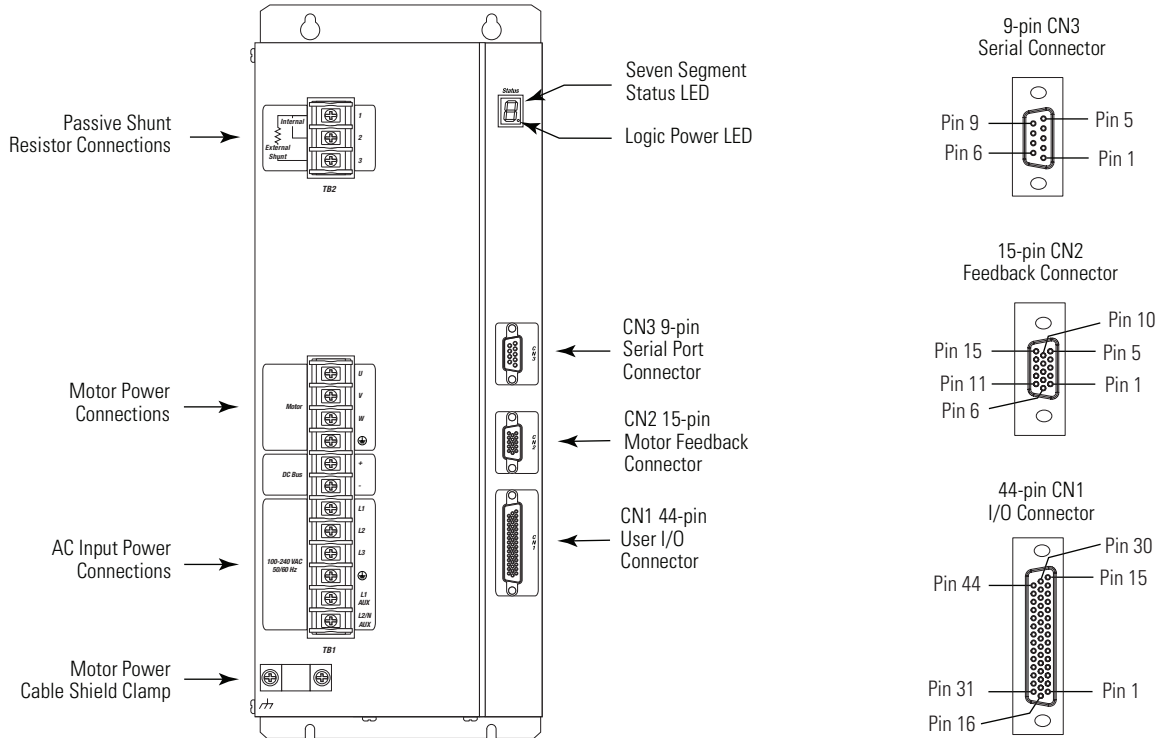

Serial Port Connector

The following table provides the signal descriptions and pin-outs for the CN3 serial port (9-pin) connector.

CN3 Pin	Description	Signal
1	RS-422/RS-485 Input+	RCV+
2	RS-232 Input	RCV
3	RS-232 Output	XMT
4	RS-422/RS-485 Output+	XMT+
5	Common	COM
6	Reserved	—
7	RS-422/RS-485 Input-	RCV-
8	RS-422/RS-485 Output-	XMT-
9	Reserved	—

I/O Connector

The following table provides the signal descriptions and pin-outs for the CN1 I/O (44-pin) connector.

CN1 Pin	Description	Signal
1	Auxiliary Encoder Power Out (+5V)	EPWR
2	Common	ECOM
3	Reserved	–
4	Auxiliary A+/Step+/CW+	AX+
5	Auxiliary A-/Step-/CW-	AX-
6	Auxiliary B+/Dir+/CCW+	BX+
7	Auxiliary B-/Dir-/CCW-	BX-
8	Auxiliary Encoder Ch I+	IX+
9	Auxiliary Encoder Ch I-	IX-
10	Unbuffered Motor Encoder Ch A+	AM+
11	Unbuffered Motor Encoder Ch A-	AM-
12	Unbuffered Motor Encoder Ch B+	BM+
13	Unbuffered Motor Encoder Ch B-	BM-
14	Unbuffered Motor Encoder Ch I+	IM+
15	Unbuffered Motor Encoder Ch I-	IM-
16	Buffered Motor Encoder Ch A+	AMOUT+
17	Buffered Motor Encoder Ch A-	AMOUT-
18	Buffered Motor Encoder Ch B+	BMOUT+
19	Buffered Motor Encoder Ch B-	BMOUT-
20	Buffered Motor Encoder Ch I+	IMOUT+
21	Buffered Motor Encoder Ch I-	IMOUT-
22	Common	ACOM

CN1 Pin	Description	Signal
23	Programmable Analog Output	AOUT
24	Analog Current Limit Input	ILIMIT
25	Command +	COMMAND+
26	Command -	COMMAND-
27	I/O Common	IOCOM
28	I/O Common	IOCOM
29	I/O Power	IOPWR
30	I/O Power	IOPWR
31	Digital Input 1	INPUT1
32	Digital Input 2	INPUT2
33	Digital Input 3	INPUT3
34	Digital Input 4	INPUT4
35	Digital Input 5	INPUT5
36	Digital Input 6	INPUT6
37	Digital Input 7	INPUT7
38	Digital Input 8	INPUT8
39	Digital Output 1	OUTPUT1
40	Digital Output 2	OUTPUT2
41	Digital Output 3	OUTPUT3
42	Digital Output 4	OUTPUT4
43	Normally Open Relay Output+	RELAY+
44	Normally Open Relay Output-	RELAY-

Motor Encoder Connector

The following table provides the signal descriptions and pin-outs for the CN2 motor encoder (15-pin) connector.

CN2 Pin	Description	Signal
1	Channel A+/Sine Differential Input+	AM+
2	Channel A-/Sine Differential Input-	AM-
3	Channel B+/Cosine Differential Input+	BM+
4	Channel B-/Cosine Differential Input-	BM-
5	Channel I+/Index Pulse+	IM+
6	Common	ECOM
7	Encoder Power (+9V)	EPWR_9V
8	Commutation Channel S3	S3

CN2 Pin	Description	Signal
9	Positive Overtravel Limit	+LIMIT
10	Channel I-/Index Pulse-	IM-
11	Thermostat	TS
12	Commutation Channel S1	S1
13	Commutation Channel S2	S2
14	Encoder Power (+5V)	EPWR_5V
15	Negative Overtravel Limit	-LIMIT

Use the figure below to locate the front panel connections on the Ultra3000 460V drives (3W, 5 kW, 10 kW, 15 kW, and 22 kW).

Figure 2.4
Ultra3000 Front Panel Connections for 2098-DSD-HVxxx and HVxxxX

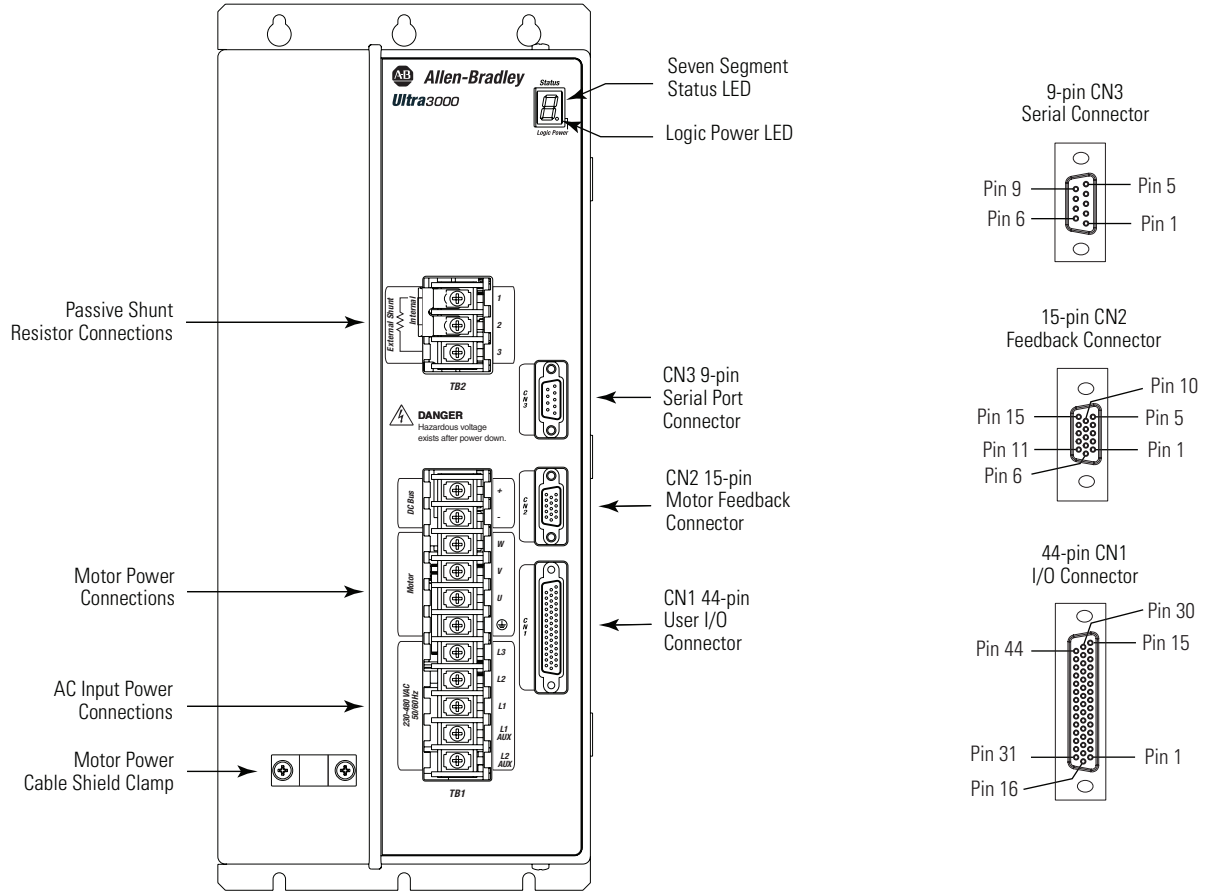

Serial Port Connector

The following table provides the signal descriptions and pin-outs for the CN3 serial port (9-pin) connector.

CN3 Pin	Description	Signal
1	RS-422/RS-485 Input+	RCV+
2	RS-232 Input	RCV
3	RS-232 Output	XMT
4	RS-422/RS-485 Output+	XMT+
5	Common	COM
6	Reserved	—
7	RS-422/RS-485 Input-	RCV-
8	RS-422/RS-485 Output-	XMT-
9	Reserved	—

I/O Connector

The following table provides the signal descriptions and pin-outs for the CN1 I/O (44-pin) connector.

CN1 Pin	Description	Signal
1	Auxiliary Encoder Power Out (+5V)	EPWR
2	Common	ECOM
3	Reserved	–
4	Auxiliary A+/Step+/CW+	AX+
5	Auxiliary A-/Step-/CW-	AX-
6	Auxiliary B+/Dir+/CCW+	BX+
7	Auxiliary B-/Dir-/CCW-	BX-
8	Auxiliary Encoder Ch I+	IX+
9	Auxiliary Encoder Ch I-	IX-
10	Unbuffered Motor Encoder Ch A+	AM+
11	Unbuffered Motor Encoder Ch A-	AM-
12	Unbuffered Motor Encoder Ch B+	BM+
13	Unbuffered Motor Encoder Ch B-	BM-
14	Unbuffered Motor Encoder Ch I+	IM+
15	Unbuffered Motor Encoder Ch I-	IM-
16	Buffered Motor Encoder Ch A+	AMOUT+
17	Buffered Motor Encoder Ch A-	AMOUT-
18	Buffered Motor Encoder Ch B+	BMOUT+
19	Buffered Motor Encoder Ch B-	BMOUT-
20	Buffered Motor Encoder Ch I+	IMOUT+
21	Buffered Motor Encoder Ch I-	IMOUT-
22	Common	ACOM

CN1 Pin	Description	Signal
23	Programmable Analog Output	AOUT
24	Analog Current Limit Input	ILIMIT
25	Command +	COMMAND+
26	Command -	COMMAND-
27	I/O Common	IOCOM
28	I/O Common	IOCOM
29	I/O Power	IOPWR
30	I/O Power	IOPWR
31	Digital Input 1	INPUT1
32	Digital Input 2	INPUT2
33	Digital Input 3	INPUT3
34	Digital Input 4	INPUT4
35	Digital Input 5	INPUT5
36	Digital Input 6	INPUT6
37	Digital Input 7	INPUT7
38	Digital Input 8	INPUT8
39	Digital Output 1	OUTPUT1
40	Digital Output 2	OUTPUT2
41	Digital Output 3	OUTPUT3
42	Digital Output 4	OUTPUT4
43	Normally Open Relay Output+	RELAY+
44	Normally Open Relay Output-	RELAY-

Motor Encoder Connector

The following table provides the signal descriptions and pin-outs for the CN2 motor encoder (15-pin) connector.

CN2 Pin	Description	Signal
1	Channel A+/Sine Differential Input+	AM+
2	Channel A-/Sine Differential Input-	AM-
3	Channel B+/Cosine Differential Input+	BM+
4	Channel B-/Cosine Differential Input-	BM-
5	Channel I+/Index Pulse+	IM+
6	Common	ECOM
7	Encoder Power (+9V)	EPWR_9V
8	Commutation Channel S3	S3

CN2 Pin	Description	Signal
9	Positive Overtravel Limit	+LIMIT
10	Channel I-/Index Pulse-	IM-
11	Thermostat	TS
12	Commutation Channel S1	S1
13	Commutation Channel S2	S2
14	Encoder Power (+5V)	EPWR_5V
15	Negative Overtravel Limit	-LIMIT

Ultra3000 (with SERCOS) Front Panel Connections

Use the figure below to locate the front panel connections on the Ultra3000 with SERCOS interface 230V drives (500W, 1 kW, and 2 kW).

Figure 2.5
Ultra3000 Front Panel Connections for 2098-DSD-005-SE, -010-SE, and -020-SE

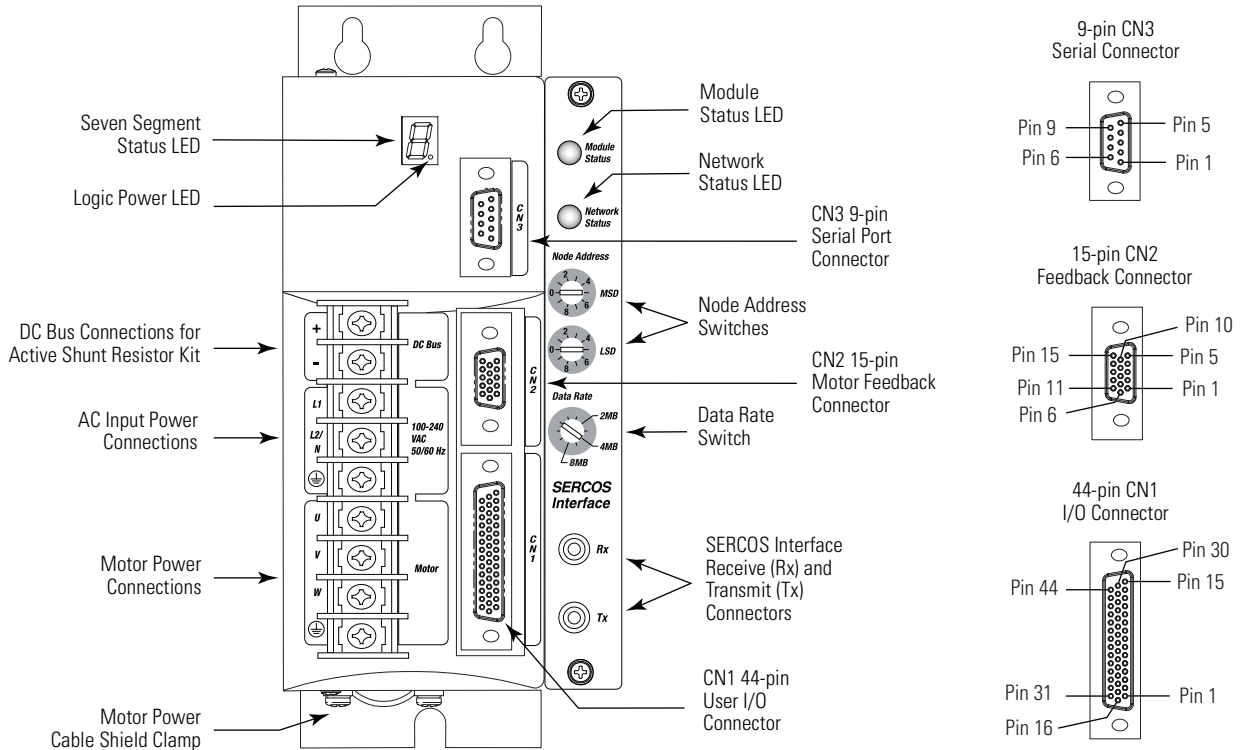

Serial Port Connector

The following table provides the signal descriptions and pin-outs for the CN3 serial port (9-pin) connector.

CN3 Pin	Description	Signal
1	RS-422/RS-485 Input+	RCV+
2	RS-232 Input	RCV
3	RS-232 Output	XMT
4	RS-422/RS-485 Output+	XMT+
5	Common	COM
6	Reserved	—
7	RS-422/RS-485 Input-	RCV-
8	RS-422/RS-485 Output-	XMT-
9	Reserved	—

I/O Connector

The following table provides the signal descriptions and pin-outs for the CN1 I/O (44-pin) connector.

CN1 Pin	Description	Signal
1	Auxiliary Encoder Power Out (+5V)	EPWR
2	Common	ECOM
3	Auxiliary Logic Power In (+5V)	AUXPWR
4	Auxiliary Encoder Ch A+	AX+
5	Auxiliary Encoder Ch A-	AX-
6	Auxiliary Encoder Ch B+	BX+
7	Auxiliary Encoder Ch B-	BX-
8	Auxiliary Encoder Ch I+	IX+
9	Auxiliary Encoder Ch I-	IX-
10	Unbuffered Motor Encoder Ch A+	AM+
11	Unbuffered Motor Encoder Ch A-	AM-
12	Unbuffered Motor Encoder Ch B+	BM+
13	Unbuffered Motor Encoder Ch B-	BM-
14	Unbuffered Motor Encoder Ch I+	IM+
15	Unbuffered Motor Encoder Ch I-	IM-
16	Buffered Motor Encoder Ch A+	AMOUT+
17	Buffered Motor Encoder Ch A-	AMOUT-
18	Buffered Motor Encoder Ch B+	BMOUT+
19	Buffered Motor Encoder Ch B-	BMOUT-
20	Buffered Motor Encoder Ch I+	IMOUT+
21	Buffered Motor Encoder Ch I-	IMOUT-
22	Common	ACOM

CN1 Pin	Description	Signal
23	Reserved	–
24	Analog Current Limit Input	ILIMIT
25	Reserved	–
26	Reserved	–
27	I/O Common	IOCOM
28	I/O Common	IOCOM
29	I/O Power	IOPWR
30	I/O Power	IOPWR
31	Drive Enable Input	ENABLE
32	Home Sensor Input	HOME
33	Registration Sensor 1 Input	REG1
34	Registration Sensor 2 Input	REG2
35	Reserved	–
36	Reserved	–
37	Positive Overtravel Input	OT_POS
38	Negative Overtravel Input	OT_NEG
39	Drive Ready	READY ¹
40	Reserved	–
41	Reserved	–
42	Reserved	–
43	Brake Relay Output+	BRAKE+
44	Brake Relay Output-	BRAKE-

¹ READY signal only available with firmware version 1.29 (or above). Requires use of drive-mounted breakout board (2090-U3CBB-DM44).

Motor Encoder Connector

The following table provides the signal descriptions and pin-outs for the CN2 motor encoder (15-pin) connector.

CN2 Pin	Description	Signal
1	Channel A+/Sine Differential Input+	AM+
2	Channel A-/Sine Differential Input-	AM-
3	Channel B+/Cosine Differential Input+	BM+
4	Channel B-/Cosine Differential Input-	BM-
5	Channel I+/Index Pulse+	IM+
6	Common	ECOM
7	Reserved	–
8	Commutation Channel S3	S3

CN2 Pin	Description	Signal
9	Positive Overtravel Limit	+LIMIT
10	Channel I-/Index Pulse-	IM-
11	Thermostat	TS
12	Commutation Channel S1	S1
13	Commutation Channel S2	S2
14	Encoder Power (+5V)	EPWR_5V
15	Negative Overtravel Limit	-LIMIT

Use the figure below to locate the front panel connections on the Ultra3000 with SERCOS interface 230V drive (3 kW).

Figure 2.6
Ultra3000 Front Panel Connections for 2098-DSD-030-SE

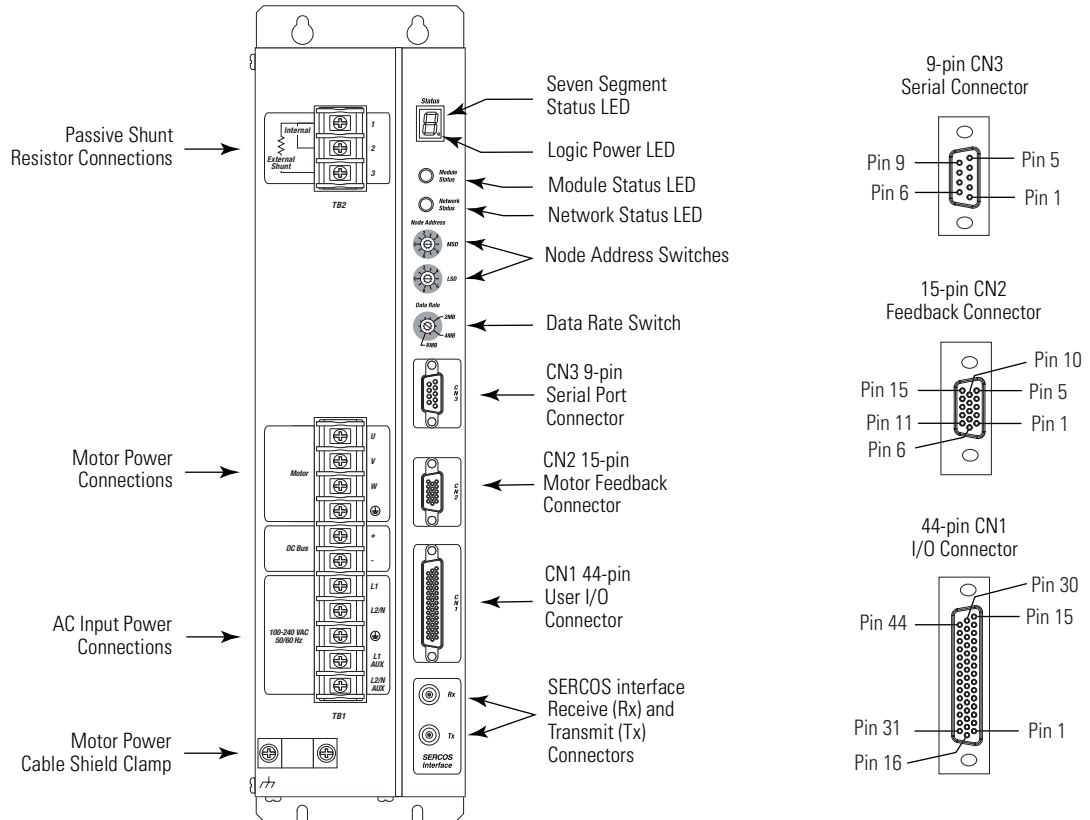

Serial Port Connector

The following table provides the signal descriptions and pin-outs for the CN3 serial port (9-pin) connector.

CN3 Pin	Description	Signal
1	RS-422/RS-485 Input+	RCV+
2	RS-232 Input	RCV
3	RS-232 Output	XMT
4	RS-422/RS-485 Output+	XMT+
5	Common	COM
6	Reserved	—
7	RS-422/RS-485 Input-	RCV-
8	RS-422/RS-485 Output-	XMT-
9	Reserved	—

I/O Connector

The following table provides the signal descriptions and pin-outs for the CN1 I/O (44-pin) connector.

CN1 Pin	Description	Signal
1	Auxiliary Encoder Power Out (+5V)	EPWR
2	Common	ECOM
3	Reserved	–
4	Auxiliary Encoder Ch A+	AX+
5	Auxiliary Encoder Ch A-	AX-
6	Auxiliary Encoder Ch B+	BX+
7	Auxiliary Encoder Ch B-	BX-
8	Auxiliary Encoder Ch I+	IX+
9	Auxiliary Encoder Ch I-	IX-
10	Unbuffered Motor Encoder Ch A+	AM+
11	Unbuffered Motor Encoder Ch A-	AM-
12	Unbuffered Motor Encoder Ch B+	BM+
13	Unbuffered Motor Encoder Ch B-	BM-
14	Unbuffered Motor Encoder Ch I+	IM+
15	Unbuffered Motor Encoder Ch I-	IM-
16	Buffered Motor Encoder Ch A+	AMOUT+
17	Buffered Motor Encoder Ch A-	AMOUT-
18	Buffered Motor Encoder Ch B+	BMOUT+
19	Buffered Motor Encoder Ch B-	BMOUT-
20	Buffered Motor Encoder Ch I+	IMOUT+
21	Buffered Motor Encoder Ch I-	IMOUT-
22	Common	ACOM

CN1 Pin	Description	Signal
23	Reserved	–
24	Analog Current Limit Input	ILIMIT
25	Reserved	–
26	Reserved	–
27	I/O Common	IOCOM
28	I/O Common	IOCOM
29	I/O Power	IOPWR
30	I/O Power	IOPWR
31	Drive Enable Input	ENABLE
32	Home Sensor Input	HOME
33	Registration Sensor 1 Input	REG1
34	Registration Sensor 2 Input	REG2
35	Reserved	–
36	Reserved	–
37	Positive Overtravel Input	OT_POS
38	Negative Overtravel Input	OT_NEG
39	Drive Ready	READY ¹
40	Reserved	–
41	Reserved	–
42	Reserved	–
43	Brake Relay Output+	BRAKE+
44	Brake Relay Output-	BRAKE-

¹ READY signal only available with firmware version 1.29 (or above). Requires use of drive-mounted breakout board (2090-U3BB2-DM44).

Motor Encoder Connector

The following table provides the signal descriptions and pin-outs for the CN2 motor encoder (15-pin) connector.

CN2 Pin	Description	Signal
1	Channel A+/Sine Differential Input+	AM+
2	Channel A-/Sine Differential Input-	AM-
3	Channel B+/Cosine Differential Input+	BM+
4	Channel B-/Cosine Differential Input-	BM-
5	Channel I+/Index Pulse+	IM+
6	Common	ECOM
7	Encoder Power (+9V)	EPWR_9V
8	Commutation Channel S3	S3

CN2 Pin	Description	Signal
9	Positive Overtravel Limit	+LIMIT
10	Channel I-/Index Pulse-	IM-
11	Thermostat	TS
12	Commutation Channel S1	S1
13	Commutation Channel S2	S2
14	Encoder Power (+5V)	EPWR_5V
15	Negative Overtravel Limit	-LIMIT

Use the figure below to locate the front panel connections on the Ultra3000 with SERCOS interface 230V drives (7.5 and 15 kW).

Figure 2.7
Ultra3000 Front Panel Connections for 2098-DSD-075-SE and -150-SE

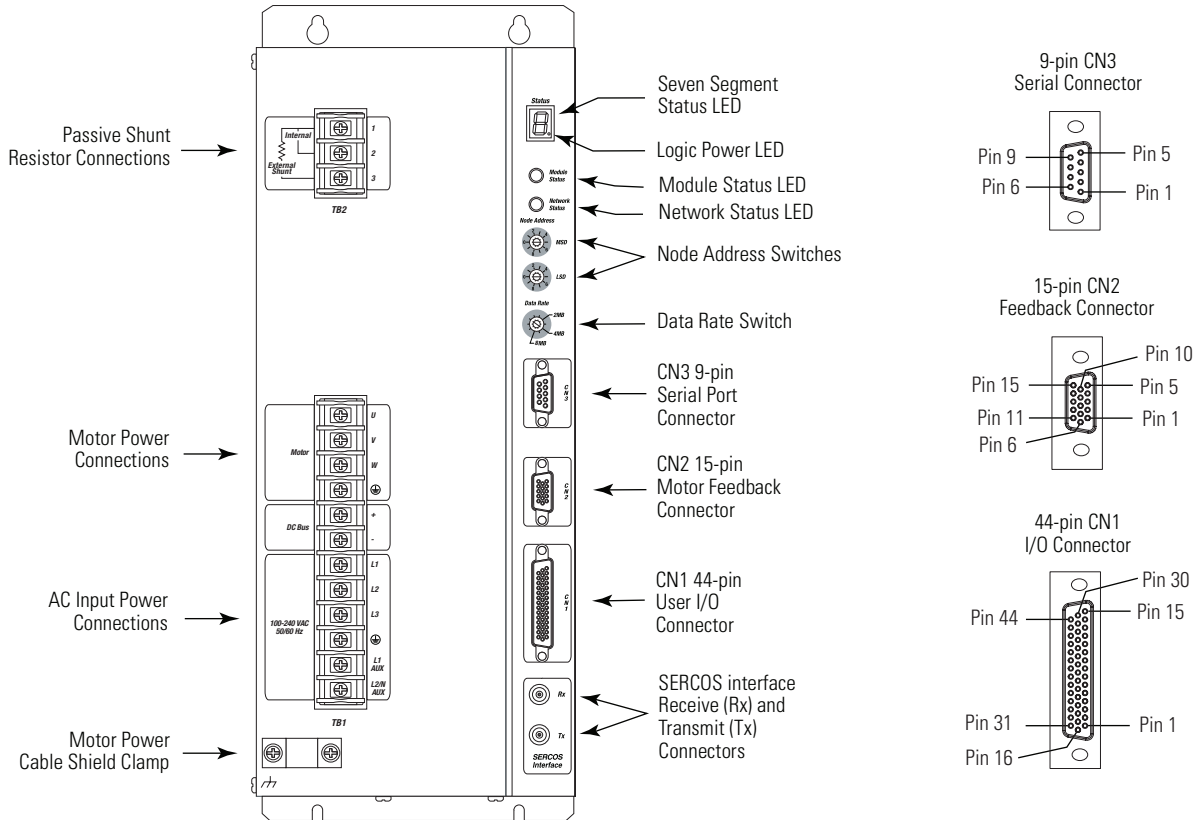

Serial Port Connector

The following table provides the signal descriptions and pin-outs for the CN3 serial port (9-pin) connector.

CN3 Pin	Description	Signal
1	RS-422/RS-485 Input+	RCV+
2	RS-232 Input	RCV
3	RS-232 Output	XMT
4	RS-422/RS-485 Output+	XMT+
5	Common	COM
6	Reserved	—
7	RS-422/RS-485 Input-	RCV-
8	RS-422/RS-485 Output-	XMT-
9	Reserved	—

I/O Connector

The following table provides the signal descriptions and pin-outs for the CN1 I/O (44-pin) connector.

CN1 Pin	Description	Signal
1	Auxiliary Encoder Power Out (+5V)	EPWR
2	Common	ECOM
3	Reserved	–
4	Auxiliary Encoder Ch A+	AX+
5	Auxiliary Encoder Ch A-	AX-
6	Auxiliary Encoder Ch B+	BX+
7	Auxiliary Encoder Ch B-	BX-
8	Auxiliary Encoder Ch I+	IX+
9	Auxiliary Encoder Ch I-	IX-
10	Unbuffered Motor Encoder Ch A+	AM+
11	Unbuffered Motor Encoder Ch A-	AM-
12	Unbuffered Motor Encoder Ch B+	BM+
13	Unbuffered Motor Encoder Ch B-	BM-
14	Unbuffered Motor Encoder Ch I+	IM+
15	Unbuffered Motor Encoder Ch I-	IM-
16	Buffered Motor Encoder Ch A+	AMOUT+
17	Buffered Motor Encoder Ch A-	AMOUT-
18	Buffered Motor Encoder Ch B+	BMOUT+
19	Buffered Motor Encoder Ch B-	BMOUT-
20	Buffered Motor Encoder Ch I+	IMOUT+
21	Buffered Motor Encoder Ch I-	IMOUT-
22	Common	ACOM

CN1 Pin	Description	Signal
23	Reserved	–
24	Analog Current Limit Input	ILIMIT
25	Reserved	–
26	Reserved	–
27	I/O Common	IOCOM
28	I/O Common	IOCOM
29	I/O Power	IOPWR
30	I/O Power	IOPWR
31	Drive Enable Input	ENABLE
32	Home Sensor Input	HOME
33	Registration Sensor 1 Input	REG1
34	Registration Sensor 2 Input	REG2
35	Reserved	–
36	Reserved	–
37	Positive Overtravel Input	OT_POS
38	Negative Overtravel Input	OT_NEG
39	Drive Ready	READY ¹
40	Reserved	–
41	Reserved	–
42	Reserved	–
43	Brake Relay Output+	BRAKE+
44	Brake Relay Output-	BRAKE-

¹ READY signal only available with firmware version 1.29 (or above). Requires use of drive-mounted breakout board (2090-U3BB2-DM44).

Motor Encoder Connector

The following table provides the signal descriptions and pin-outs for the CN2 motor encoder (15-pin) connector.

CN2 Pin	Description	Signal
1	Channel A+/Sine Differential Input+	AM+
2	Channel A-/Sine Differential Input-	AM-
3	Channel B+/Cosine Differential Input+	BM+
4	Channel B-/Cosine Differential Input-	BM-
5	Channel I+/Index Pulse+	IM+
6	Common	ECOM
7	Encoder Power (+9V)	EPWR_9V
8	Commutation Channel S3	S3

CN2 Pin	Description	Signal
9	Positive Overtravel Limit	+LIMIT
10	Channel I-/Index Pulse-	IM-
11	Thermostat	TS
12	Commutation Channel S1	S1
13	Commutation Channel S2	S2
14	Encoder Power (+5V)	EPWR_5V
15	Negative Overtravel Limit	-LIMIT

Use the figure below to locate the front panel connections on the Ultra3000 with SERCOS interface 460V drives (3 kW, 5 kW, 10 kW, 15 kW, and 22 kW).

Figure 2.8
Ultra3000 Front Panel Connections for 2098-DSD-HVxxx-SE

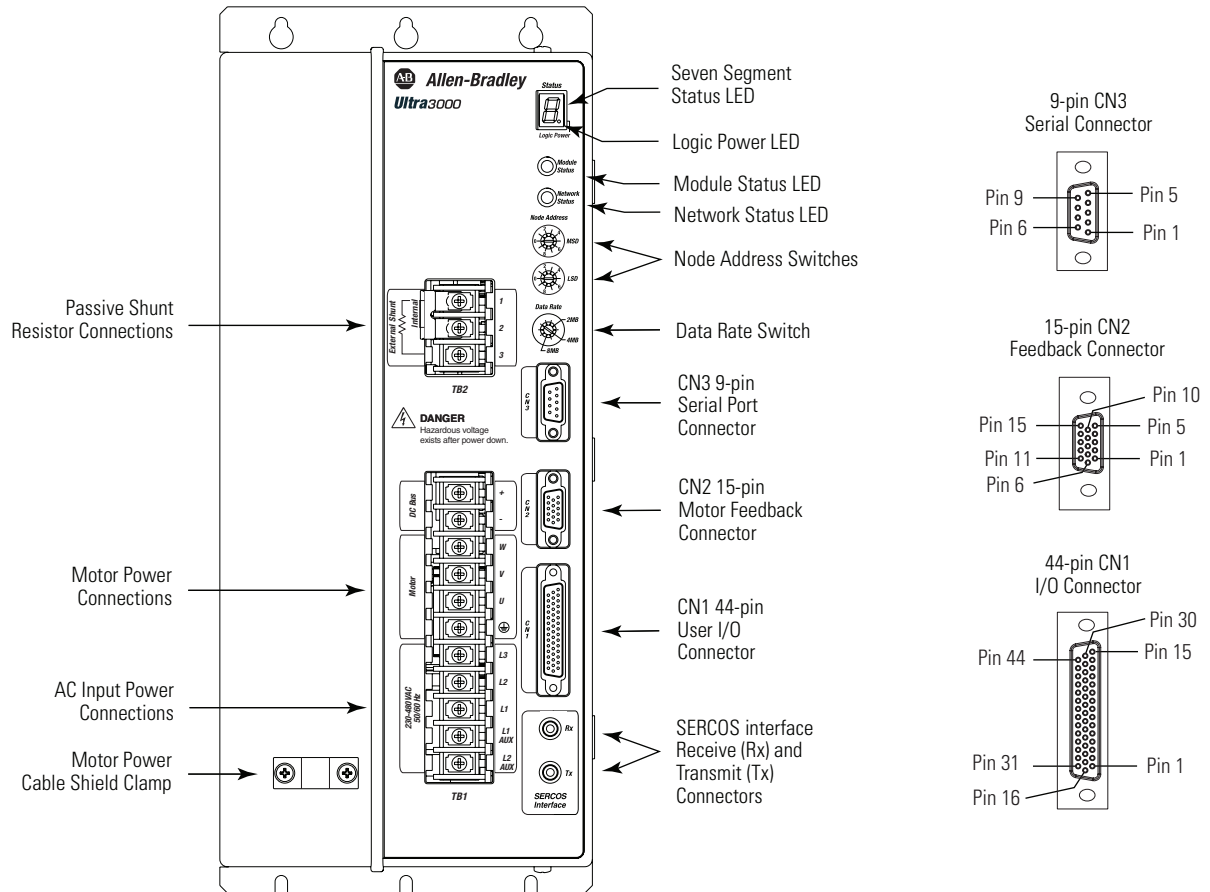

Serial Port Connector

The following table provides the signal descriptions and pin-outs for the CN3 serial port (9-pin) connector.

CN3 Pin	Description	Signal
1	RS-422/RS-485 Input+	RCV+
2	RS-232 Input	RCV
3	RS-232 Output	XMT
4	RS-422/RS-485 Output+	XMT+
5	Common	COM
6	Reserved	—
7	RS-422/RS-485 Input-	RCV-
8	RS-422/RS-485 Output-	XMT-
9	Reserved	—

I/O Connector

The following table provides the signal descriptions and pin-outs for the CN1 I/O (44-pin) connector.

CN1 Pin	Description	Signal
1	Auxiliary Encoder Power Out (+5V)	EPWR
2	Common	ECOM
3	Reserved	–
4	Auxiliary Encoder Ch A+	AX+
5	Auxiliary Encoder Ch A-	AX-
6	Auxiliary Encoder Ch B+	BX+
7	Auxiliary Encoder Ch B-	BX-
8	Auxiliary Encoder Ch I+	IX+
9	Auxiliary Encoder Ch I-	IX-
10	Unbuffered Motor Encoder Ch A+	AM+
11	Unbuffered Motor Encoder Ch A-	AM-
12	Unbuffered Motor Encoder Ch B+	BM+
13	Unbuffered Motor Encoder Ch B-	BM-
14	Unbuffered Motor Encoder Ch I+	IM+
15	Unbuffered Motor Encoder Ch I-	IM-
16	Buffered Motor Encoder Ch A+	AMOUT+
17	Buffered Motor Encoder Ch A-	AMOUT-
18	Buffered Motor Encoder Ch B+	BMOUT+
19	Buffered Motor Encoder Ch B-	BMOUT-
20	Buffered Motor Encoder Ch I+	IMOUT+
21	Buffered Motor Encoder Ch I-	IMOUT-
22	Common	ACOM

CN1 Pin	Description	Signal
23	Reserved	–
24	Analog Current Limit Input	ILIMIT
25	Reserved	–
26	Reserved	–
27	I/O Common	IOCOM
28	I/O Common	IOCOM
29	I/O Power	IOPWR
30	I/O Power	IOPWR
31	Drive Enable Input	ENABLE
32	Home Sensor Input	HOME
33	Registration Sensor 1 Input	REG1
34	Registration Sensor 2 Input	REG2
35	Reserved	–
36	Reserved	–
37	Positive Overtravel Input	OT_POS
38	Negative Overtravel Input	OT_NEG
39	Drive Ready	READY ¹
40	Reserved	–
41	Reserved	–
42	Reserved	–
43	Brake Relay Output+	BRAKE+
44	Brake Relay Output-	BRAKE-

¹ READY signal only available with firmware version 1.29 (or above). Requires use of drive-mounted breakout board (2090-U3BB2-DM44).

Motor Encoder Connector

The following table provides the signal descriptions and pin-outs for the CN2 motor encoder (15-pin) connector.

CN2 Pin	Description	Signal
1	Channel A+/Sine Differential Input+	AM+
2	Channel A-/Sine Differential Input-	AM-
3	Channel B+/Cosine Differential Input+	BM+
4	Channel B-/Cosine Differential Input-	BM-
5	Channel I+/Index Pulse+	IM+
6	Common	ECOM
7	Encoder Power (+9V)	EPWR_9V
8	Commutation Channel S3	S3

CN2 Pin	Description	Signal
9	Positive Overtravel Limit	+LIMIT
10	Channel I-/Index Pulse-	IM-
11	Thermostat	TS
12	Commutation Channel S1	S1
13	Commutation Channel S2	S2
14	Encoder Power (+5V)	EPWR_5V
15	Negative Overtravel Limit	-LIMIT

Ultra3000 (with DeviceNet) Front Panel Connections

Use the figure below to locate the front panel connections on the Ultra3000 with DeviceNet Interface 230V drives (500W, 1 kW, and 2 kW).

Figure 2.9
Ultra3000 Front Panel Connections
 for 2098-DSD-005-DN, -005X-DN, -010-DN, -010X-DN, -020-DN, and -020X-DN

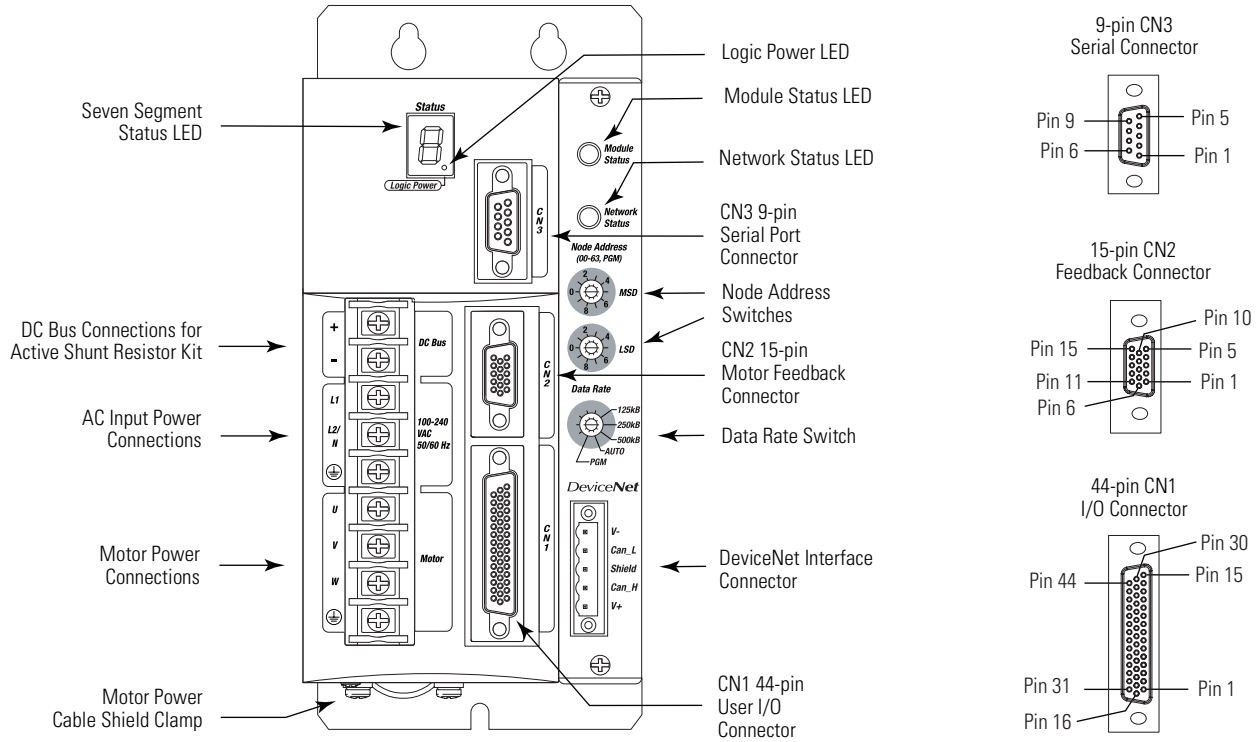

Serial Port Connector

The following table provides the signal descriptions and pin-outs for the CN3 serial port (9-pin) connector.

CN3 Pin	Description	Signal
1	RS-422/RS-485 Input+	RCV+
2	RS-232 Input	RCV
3	RS-232 Output	XMT
4	RS-422/RS-485 Output+	XMT+
5	Common	COM
6	Reserved	—
7	RS-422/RS-485 Input-	RCV-
8	RS-422/RS-485 Output-	XMT-
9	Reserved	—

I/O Connector

The following table provides the signal descriptions and pin-outs for the CN1 I/O (44-pin) connector.

CN1 Pin	Description	Signal
1	Auxiliary Encoder Power Out (+5V)	EPWR
2	Common	ECOM
3	Auxiliary Logic Power In (+5V)	AUXPWR
4	Auxiliary A+/Step+/CW+	AX+
5	Auxiliary A-/Step-/CW-	AX-
6	Auxiliary B+/Dir+/CCW+	BX+
7	Auxiliary B-/Dir-/CCW-	BX-
8	Auxiliary Encoder Ch I+	IX+
9	Auxiliary Encoder Ch I-	IX-
10	Unbuffered Motor Encoder Ch A+	AM+
11	Unbuffered Motor Encoder Ch A-	AM-
12	Unbuffered Motor Encoder Ch B+	BM+
13	Unbuffered Motor Encoder Ch B-	BM-
14	Unbuffered Motor Encoder Ch I+	IM+
15	Unbuffered Motor Encoder Ch I-	IM-
16	Buffered Motor Encoder Ch A+	AMOUT+
17	Buffered Motor Encoder Ch A-	AMOUT-
18	Buffered Motor Encoder Ch B+	BMOUT+
19	Buffered Motor Encoder Ch B-	BMOUT-
20	Buffered Motor Encoder Ch I+	IMOUT+
21	Buffered Motor Encoder Ch I-	IMOUT-
22	Common	ACOM

CN1 Pin	Description	Signal
23	Programmable Analog Output	AOUT
24	Analog Current Limit Input	ILIMIT
25	Command +	COMMAND+
26	Command -	COMMAND-
27	I/O Common	IOCOM
28	I/O Common	IOCOM
29	I/O Power	IOPWR
30	I/O Power	IOPWR
31	Digital Input 1	INPUT1
32	Digital Input 2	INPUT2
33	Digital Input 3	INPUT3
34	Digital Input 4	INPUT4
35	Digital Input 5	INPUT5
36	Digital Input 6	INPUT6
37	Digital Input 7	INPUT7
38	Digital Input 8	INPUT8
39	Digital Output 1	OUTPUT1
40	Digital Output 2	OUTPUT2
41	Digital Output 3	OUTPUT3
42	Digital Output 4	OUTPUT4
43	Normally Open Relay Output+	RELAY+
44	Normally Open Relay Output-	RELAY-

Motor Encoder Connector

The following table provides the signal descriptions and pin-outs for the CN2 motor encoder (15-pin) connector.

CN2 Pin	Description	Signal
1	Channel A+/Sine Differential Input+	AM+
2	Channel A-/Sine Differential Input-	AM-
3	Channel B+/Cosine Differential Input+	BM+
4	Channel B-/Cosine Differential Input-	BM-
5	Channel I+/Index Pulse+	IM+
6	Common	ECOM
7	Reserved	-
8	Commutation Channel S3	S3

CN2 Pin	Description	Signal
9	Positive Overtravel Limit	+LIMIT
10	Channel I-/Index Pulse-	IM-
11	Thermostat	TS
12	Commutation Channel S1	S1
13	Commutation Channel S2	S2
14	Encoder Power (+5V)	EPWR_5V
15	Negative Overtravel Limit	-LIMIT

Use the figure below to locate the front panel connections on the Ultra3000 with DeviceNet Interface 230V drives (3 kW).

Figure 2.10
Ultra3000 Front Panel Connections for 2098-DSD-030-DN and -030X-DN

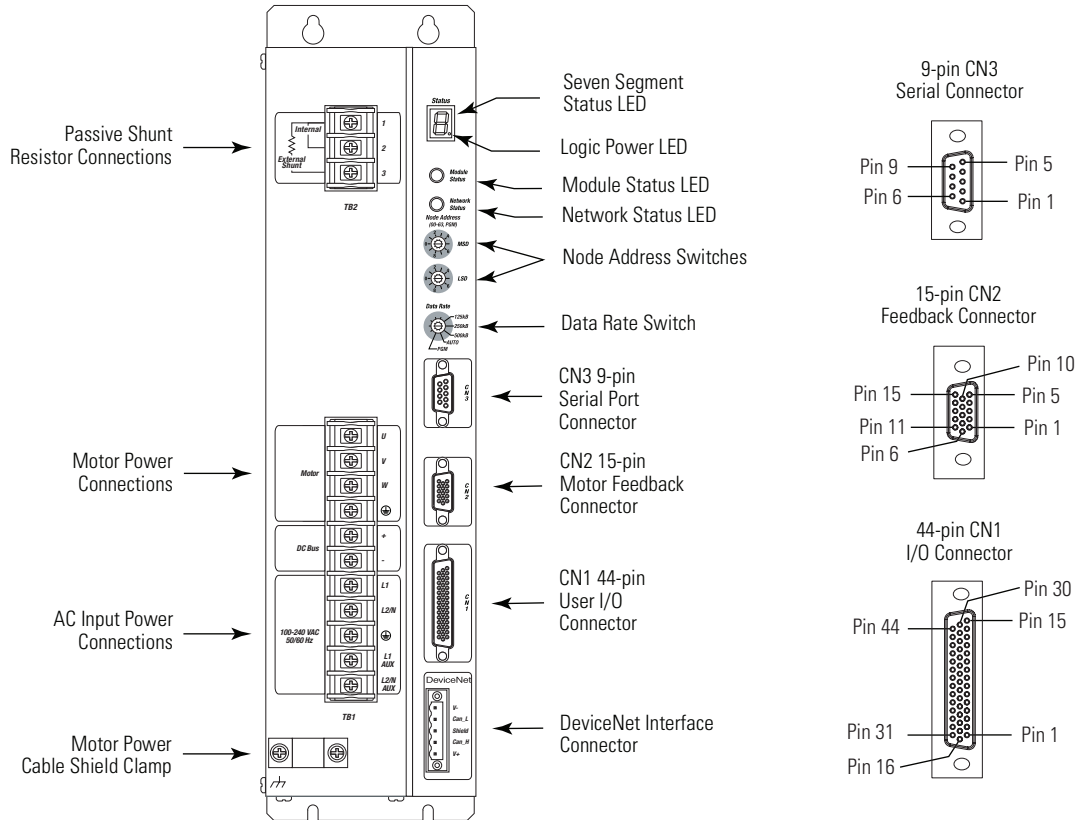

Serial Port Connector

The following table provides the signal descriptions and pin-outs for the CN3 serial port (9-pin) connector.

CN3 Pin	Description	Signal
1	RS-422/RS-485 Input+	RCV+
2	RS-232 Input	RCV
3	RS-232 Output	XMT
4	RS-422/RS-485 Output+	XMT+
5	Common	COM
6	Reserved	—
7	RS-422/RS-485 Input-	RCV-
8	RS-422/RS-485 Output-	XMT-
9	Reserved	—

I/O Connector

The following table provides the signal descriptions and pin-outs for the CN1 I/O (44-pin) connector.

CN1 Pin	Description	Signal
1	Auxiliary Encoder Power Out (+5V)	EPWR
2	Common	ECOM
3	Reserved	–
4	Auxiliary A+/Step+/CW+	AX+
5	Auxiliary A-/Step-/CW-	AX-
6	Auxiliary B+/Dir+/CCW+	BX+
7	Auxiliary B-/Dir-/CCW-	BX-
8	Auxiliary Encoder Ch I+	IX+
9	Auxiliary Encoder Ch I-	IX-
10	Unbuffered Motor Encoder Ch A+	AM+
11	Unbuffered Motor Encoder Ch A-	AM-
12	Unbuffered Motor Encoder Ch B+	BM+
13	Unbuffered Motor Encoder Ch B-	BM-
14	Unbuffered Motor Encoder Ch I+	IM+
15	Unbuffered Motor Encoder Ch I-	IM-
16	Buffered Motor Encoder Ch A+	AMOUT+
17	Buffered Motor Encoder Ch A-	AMOUT-
18	Buffered Motor Encoder Ch B+	BMOUT+
19	Buffered Motor Encoder Ch B-	BMOUT-
20	Buffered Motor Encoder Ch I+	IMOUT+
21	Buffered Motor Encoder Ch I-	IMOUT-
22	Common	ACOM

CN1 Pin	Description	Signal
23	Programmable Analog Output	AOUT
24	Analog Current Limit Input	ILIMIT
25	Command +	COMMAND+
26	Command -	COMMAND-
27	I/O Common	IOCOM
28	I/O Common	IOCOM
29	I/O Power	IOPWR
30	I/O Power	IOPWR
31	Digital Input 1	INPUT1
32	Digital Input 2	INPUT2
33	Digital Input 3	INPUT3
34	Digital Input 4	INPUT4
35	Digital Input 5	INPUT5
36	Digital Input 6	INPUT6
37	Digital Input 7	INPUT7
38	Digital Input 8	INPUT8
39	Digital Output 1	OUTPUT1
40	Digital Output 2	OUTPUT2
41	Digital Output 3	OUTPUT3
42	Digital Output 4	OUTPUT4
43	Normally Open Relay Output+	RELAY+
44	Normally Open Relay Output-	RELAY-

Motor Encoder Connector

The following table provides the signal descriptions and pin-outs for the CN2 motor encoder (15-pin) connector.

CN2 Pin	Description	Signal
1	Channel A+/Sine Differential Input+	AM+
2	Channel A-/Sine Differential Input-	AM-
3	Channel B+/Cosine Differential Input+	BM+
4	Channel B-/Cosine Differential Input-	BM-
5	Channel I+/Index Pulse+	IM+
6	Common	ECOM
7	Encoder Power (+9V)	EPWR_9V
8	Commutation Channel S3	S3

CN2 Pin	Description	Signal
9	Positive Overtravel Limit	+LIMIT
10	Channel I-/Index Pulse-	IM-
11	Thermostat	TS
12	Commutation Channel S1	S1
13	Commutation Channel S2	S2
14	Encoder Power (+5V)	EPWR_5V
15	Negative Overtravel Limit	-LIMIT

Use the figure below to locate the front panel connections on the Ultra3000 with DeviceNet Interface 230V drives (7.5 and 15 kW).

Figure 2.11
Ultra3000 Front Panel Connections
for 2098-DSD-075-DN, -075X-DN, -150-DN, and -150X-DN

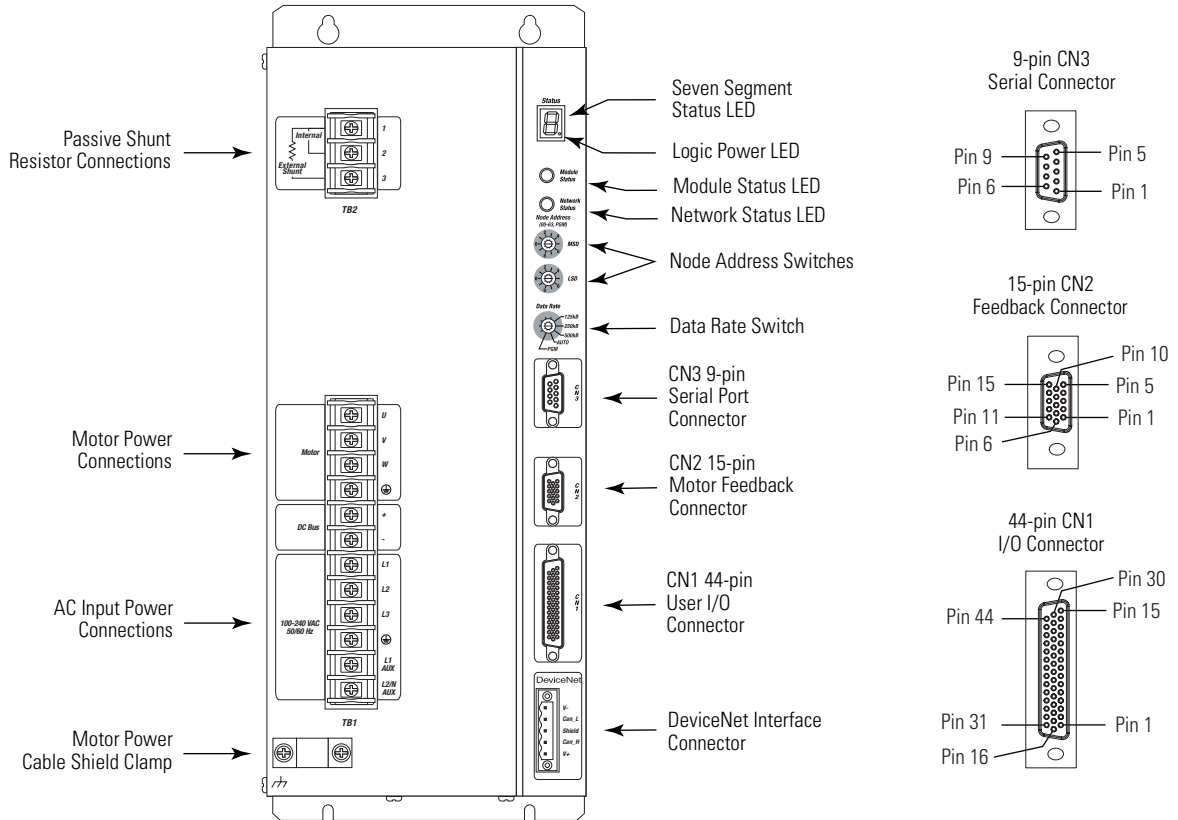

Serial Port Connector

The following table provides the signal descriptions and pin-outs for the CN3 serial port (9-pin) connector.

CN3 Pin	Description	Signal
1	RS-422/RS-485 Input+	RCV+
2	RS-232 Input	RCV
3	RS-232 Output	XMT
4	RS-422/RS-485 Output+	XMT+
5	Common	COM
6	Reserved	—
7	RS-422/RS-485 Input-	RCV-
8	RS-422/RS-485 Output-	XMT-
9	Reserved	—

I/O Connector

The following table provides the signal descriptions and pin-outs for the CN1 I/O (44-pin) connector.

CN1 Pin	Description	Signal
1	Auxiliary Encoder Power Out (+5V)	EPWR
2	Common	ECOM
3	Reserved	–
4	Auxiliary A+/Step+/CW+	AX+
5	Auxiliary A-/Step-/CW-	AX-
6	Auxiliary B+/Dir+/CCW+	BX+
7	Auxiliary B-/Dir-/CCW-	BX-
8	Auxiliary Encoder Ch I+	IX+
9	Auxiliary Encoder Ch I-	IX-
10	Unbuffered Motor Encoder Ch A+	AM+
11	Unbuffered Motor Encoder Ch A-	AM-
12	Unbuffered Motor Encoder Ch B+	BM+
13	Unbuffered Motor Encoder Ch B-	BM-
14	Unbuffered Motor Encoder Ch I+	IM+
15	Unbuffered Motor Encoder Ch I-	IM-
16	Buffered Motor Encoder Ch A+	AMOUT+
17	Buffered Motor Encoder Ch A-	AMOUT-
18	Buffered Motor Encoder Ch B+	BMOUT+
19	Buffered Motor Encoder Ch B-	BMOUT-
20	Buffered Motor Encoder Ch I+	IMOUT+
21	Buffered Motor Encoder Ch I-	IMOUT-
22	Common	ACOM

CN1 Pin	Description	Signal
23	Programmable Analog Output	AOUT
24	Analog Current Limit Input	ILIMIT
25	Command +	COMMAND+
26	Command -	COMMAND-
27	I/O Common	IOCOM
28	I/O Common	IOCOM
29	I/O Power	IOPWR
30	I/O Power	IOPWR
31	Digital Input 1	INPUT1
32	Digital Input 2	INPUT2
33	Digital Input 3	INPUT3
34	Digital Input 4	INPUT4
35	Digital Input 5	INPUT5
36	Digital Input 6	INPUT6
37	Digital Input 7	INPUT7
38	Digital Input 8	INPUT8
39	Digital Output 1	OUTPUT1
40	Digital Output 2	OUTPUT2
41	Digital Output 3	OUTPUT3
42	Digital Output 4	OUTPUT4
43	Normally Open Relay Output+	RELAY+
44	Normally Open Relay Output-	RELAY-

Motor Encoder Connector

The following table provides the signal descriptions and pin-outs for the CN2 motor encoder (15-pin) connector.

CN2 Pin	Description	Signal
1	Channel A+/Sine Differential Input+	AM+
2	Channel A-/Sine Differential Input-	AM-
3	Channel B+/Cosine Differential Input+	BM+
4	Channel B-/Cosine Differential Input-	BM-
5	Channel I+/Index Pulse+	IM+
6	Common	ECOM
7	Encoder Power (+9V)	EPWR_9V
8	Commutation Channel S3	S3

CN2 Pin	Description	Signal
9	Positive Overtravel Limit	+LIMIT
10	Channel I-/Index Pulse-	IM-
11	Thermostat	TS
12	Commutation Channel S1	S1
13	Commutation Channel S2	S2
14	Encoder Power (+5V)	EPWR_5V
15	Negative Overtravel Limit	-LIMIT

Use the figure below to locate the front panel connections on the Ultra3000 with DeviceNet Interface 460V drives (3 kW, 5 kW, 10 kW, 15 kW, and 22 kW).

Figure 2.12
Ultra3000 Front Panel Connections for 2098-DSD-HVxxx-DN and HVxxxX-DN

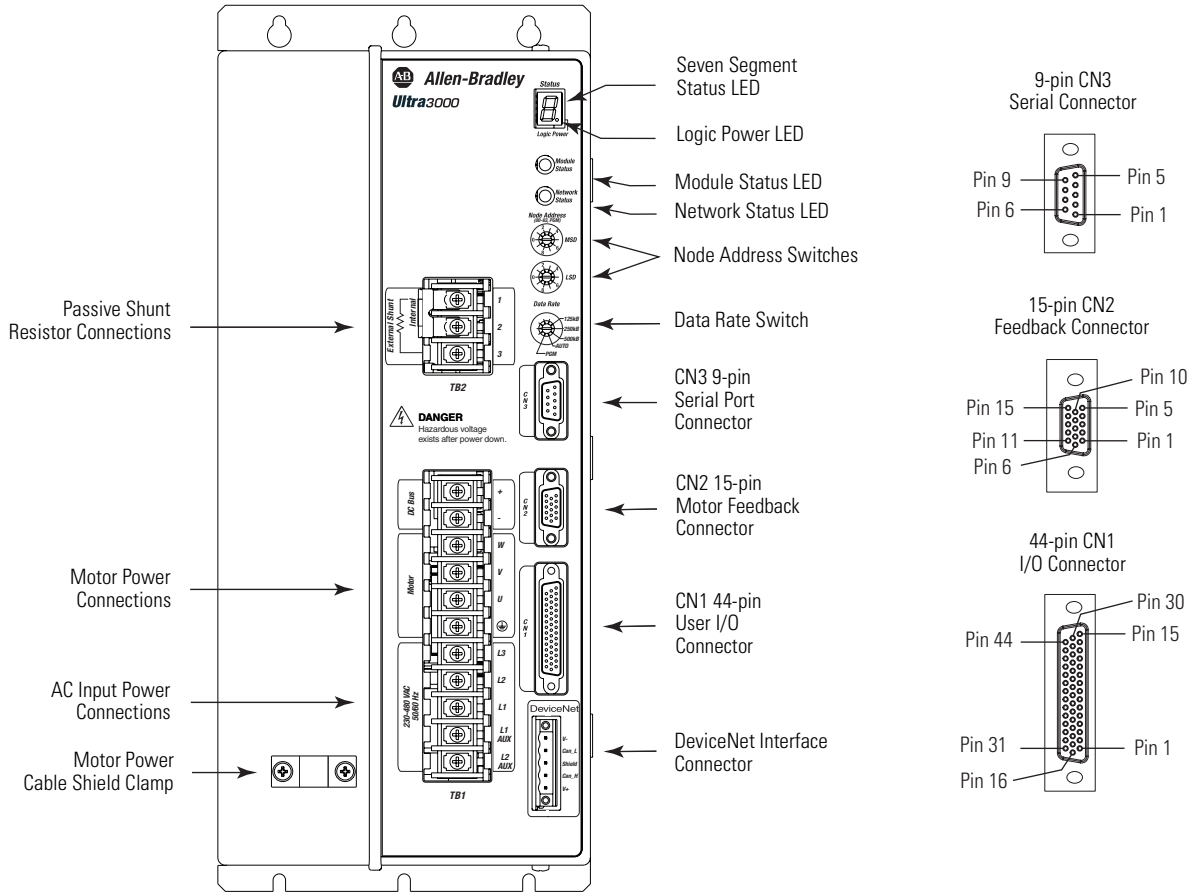

Serial Port Connector

The following table provides the signal descriptions and pin-outs for the CN3 serial port (9-pin) connector.

CN3 Pin	Description	Signal
1	RS-422/RS-485 Input+	RCV+
2	RS-232 Input	RCV
3	RS-232 Output	XMT
4	RS-422/RS-485 Output+	XMT+
5	Common	COM
6	Reserved	—
7	RS-422/RS-485 Input-	RCV-
8	RS-422/RS-485 Output-	XMT-
9	Reserved	—

I/O Connector

The following table provides the signal descriptions and pin-outs for the CN1 I/O (44-pin) connector.

CN1 Pin	Description	Signal
1	Auxiliary Encoder Power Out (+5V)	EPWR
2	Common	ECOM
3	Reserved	–
4	Auxiliary A+/Step+/CW+	AX+
5	Auxiliary A-/Step-/CW-	AX-
6	Auxiliary B+/Dir+/CCW+	BX+
7	Auxiliary B-/Dir-/CCW-	BX-
8	Auxiliary Encoder Ch I+	IX+
9	Auxiliary Encoder Ch I-	IX-
10	Unbuffered Motor Encoder Ch A+	AM+
11	Unbuffered Motor Encoder Ch A-	AM-
12	Unbuffered Motor Encoder Ch B+	BM+
13	Unbuffered Motor Encoder Ch B-	BM-
14	Unbuffered Motor Encoder Ch I+	IM+
15	Unbuffered Motor Encoder Ch I-	IM-
16	Buffered Motor Encoder Ch A+	AMOUT+
17	Buffered Motor Encoder Ch A-	AMOUT-
18	Buffered Motor Encoder Ch B+	BMOUT+
19	Buffered Motor Encoder Ch B-	BMOUT-
20	Buffered Motor Encoder Ch I+	IMOUT+
21	Buffered Motor Encoder Ch I-	IMOUT-
22	Common	ACOM

CN1 Pin	Description	Signal
23	Programmable Analog Output	AOUT
24	Analog Current Limit Input	ILIMIT
25	Command +	COMMAND+
26	Command -	COMMAND-
27	I/O Common	IOCOM
28	I/O Common	IOCOM
29	I/O Power	IOPWR
30	I/O Power	IOPWR
31	Digital Input 1	INPUT1
32	Digital Input 2	INPUT2
33	Digital Input 3	INPUT3
34	Digital Input 4	INPUT4
35	Digital Input 5	INPUT5
36	Digital Input 6	INPUT6
37	Digital Input 7	INPUT7
38	Digital Input 8	INPUT8
39	Digital Output 1	OUTPUT1
40	Digital Output 2	OUTPUT2
41	Digital Output 3	OUTPUT3
42	Digital Output 4	OUTPUT4
43	Normally Open Relay Output+	RELAY+
44	Normally Open Relay Output-	RELAY-

Motor Encoder Connector

The following table provides the signal descriptions and pin-outs for the CN2 motor encoder (15-pin) connector.

CN2 Pin	Description	Signal
1	Channel A+/Sine Differential Input+	AM+
2	Channel A-/Sine Differential Input-	AM-
3	Channel B+/Cosine Differential Input+	BM+
4	Channel B-/Cosine Differential Input-	BM-
5	Channel I+/Index Pulse+	IM+
6	Common	ECOM
7	Encoder Power (+9V)	EPWR_9V
8	Commutation Channel S3	S3

CN2 Pin	Description	Signal
9	Positive Overtravel Limit	+LIMIT
10	Channel I-/Index Pulse-	IM-
11	Thermostat	TS
12	Commutation Channel S1	S1
13	Commutation Channel S2	S2
14	Encoder Power (+5V)	EPWR_5V
15	Negative Overtravel Limit	-LIMIT

Understanding Ultra3000 I/O Specifications

A description of the Ultra3000 digital I/O power requirements and I/O signal specifications is provided on the following pages. Also included are I/O circuitry examples.

Digital I/O Power Supply

All Ultra3000 drives require an isolated external 12-24V power supply for proper operation of the digital I/O.

IMPORTANT

Do not tie the 24V digital I/O common (CN1-27 and -28) to the auxiliary encoder +5V common (CN1-2).

The following table provides a description of the digital I/O power supply (CN1-29 and -30).

Parameter	Description	Minimum	Maximum
I/O Power Supply Voltage	Voltage range of the external power supply for proper operation of the digital I/O.	10.8V	26.4V
I/O Power Supply Current	Current draw from the external power supply for the digital I/O, not including the relay output usage.	—	300 mA

Auxiliary 5V Logic Supply

The Ultra3000 drives (2098-DSD-005, -010, and -020) require an external +5V power supply in applications in which it is necessary to maintain logic power when the AC line voltage is removed. The +24V I/O supply (IOPWR) allows use of the drive-mounted breakout boards with 24V to 5V dc converter (2090-U3CBB-DM12 and -DM44). The following table provides a description of the +24V (IOPWR) power supply requirements when used to maintain logic power.

Parameter	Description	Minimum	Maximum
Input Voltage Range	Input voltage range of the external power supply for drive-mounted breakout boards with 24V to 5V converter.	18V	30V
Input Current	Input current draw from the external power supply for the drive-mounted breakout boards with 24V to 5V converter.	—	400 mA

IMPORTANT

A single 24V power supply can be used to power the digital I/O and supply 24V to the drive-mounted breakout boards (2090-U3CBB-DMxx) provided the cumulative minimum current requirements are met.

Two versions of the drive-mounted breakout board with 24V to 5V auxiliary power converter exist:

- 12-pin CN1 connector designed for use with SERCOS interface applications (catalog number 2090-U3CBB-DM12)
- 44-pin CN1 connector (catalog number 2090-U3CBB-DM44)

If an auxiliary +5V dc logic supply is used, the SERCOS ring remains active and motor position can be monitored by the drive even when the AC input power is removed. Since the drive is able to monitor the motor position, additional homing sequences can be avoided when the AC input power is re-applied.

IMPORTANT

Only the 2098-DSD-005, -010, and -020 models support an auxiliary +5V logic supply since an auxiliary AC input is not available. Refer to *Chapter 3* for more information on the auxiliary AC input.

IMPORTANT

Whenever the auxiliary +5V dc logic supply is used and the AC input supply is disconnected, the drive must be disabled. When the AC input supply is reconnected, the drive should not be re-enabled for at least 1.0 second, to allow the power stage circuitry to fully charge.

IMPORTANT

Once the AC input supply is applied, the auxiliary +5V dc logic supply must not be interrupted. Removing the +5V dc logic supply with the AC input voltage applied will cause the drive to reboot and loss of control will occur.

Using an External +5V Logic Supply

When using an external +5V dc power supply with your Ultra3000 (2098-DSD-005, -010, and -020), the +5V dc must not be grounded inside the supply, since it will be referenced to the drive common. External +5V dc power supply connections should be made to CN1-2 and CN1-3.

IMPORTANT

Using the drive-mounted breakout board with 24V to 5V auxiliary power converter is preferred to using an external +5V dc power supply.

The following table provides a description of the requirements for an external +5V dc power supply used to power the logic.

Parameter	Description	Minimum	Maximum
Voltage	Voltage tolerance of the external logic supply.	5.1V	5.25V
Current	Current output capability of the external +5V dc power supply.	1.5A	—

Digital Inputs

There are eight opto-isolated digital inputs. All digital inputs (SERCOS and non-SERCOS) have the same configuration, as shown in the figure below.

Figure 2.13
Digital Input Circuit

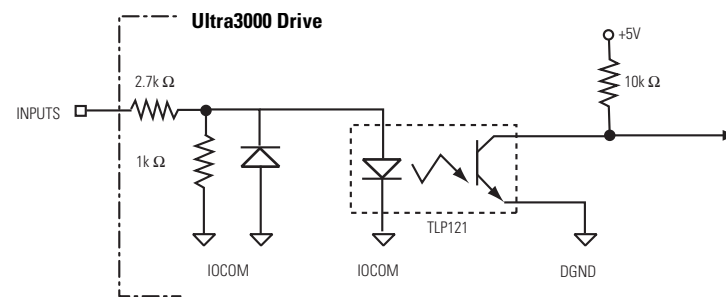

The following table provides a description of the digital input specifications.

Parameter	Description	Minimum	Maximum
ON State Voltage	Voltage applied to the input, with respect to IOCOM, to guarantee an ON state.	10.8V	26.4V
ON State Current	Current flow to guarantee an ON State	3.0 mA	12.0 mA
OFF State Voltage	Voltage applied to the input, with respect to IOCOM, to guarantee an OFF state.	-1.0V	2.0V
Propagation Delay	Signal propagation delay from the digital input to the firmware-accessible registers.	—	100 μ S

On SERCOS drives, the following inputs have dedicated functionality.

Pin	Signal	Description
CN1-31	ENABLE	Drive Enable Input, an active state enables the power electronics to control the motor.
CN1-32	HOME	Home Sensor, an active state indicates to a homing sequence that the sensor has been seen.
CN1-33 CN1-34	REG1 REG2	Registration Sensor, a transition is used to record position values.
CN1-37 CN1-38	OT_POS OT_NEG	Overtravel Input, an inactive state indicates that a position limit has been exceeded. An active state occurs when 24V is removed from the input.

IMPORTANT

Overtravel limit input devices must be normally closed.

On non-SERCOS drives, digital inputs can be configured for a variety of functions using Ultraware. Refer to Ultraware Help for digital input functionality.

Assigned Preselect Inputs

Active or inactive states select one of 64 presets shown in the following binary table. Active state indicates current flow through the input optocoupler. Inactive state indicates no current flow.

Preset Selects	Binary Code						Selected Preset or Index	
	5	4	3	2	1	0		
Select up to 64 locations via preselect inputs 5 through 0 using BCD format. (codes for preset selects 1 and 0 are shown)	0	0	0	0	0	0	Preset 0 or Index 0 is selected.	
	0	0	0	0	0	1	Preset 1 or Index 1 is selected.	
	0	0	0	0	1	0	Preset 2 or Index 2 is selected.	
	0	0	0	0	1	1	Preset 3 or Index 3 is selected.	
				↓				
		1	1	1	1	1	1	Preset 64 or Index 64 is selected.

Input Interface Examples for Active High Inputs

Figure 2.14
Drive Input Connected to Switch/Relay Contact

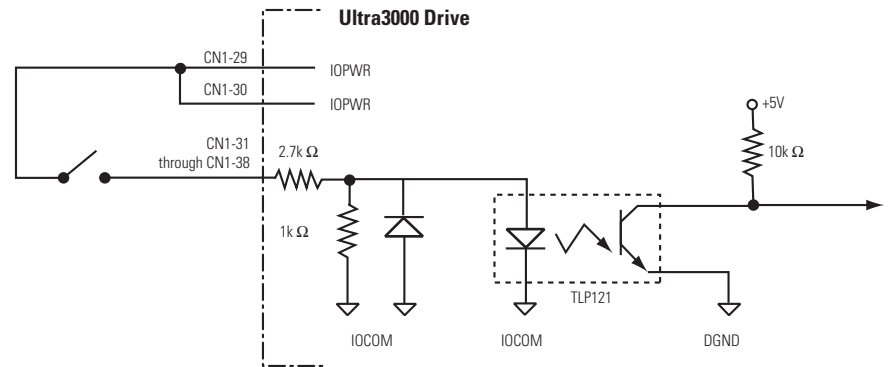

Figure 2.15
Drive Input Connected to Opto-Isolator

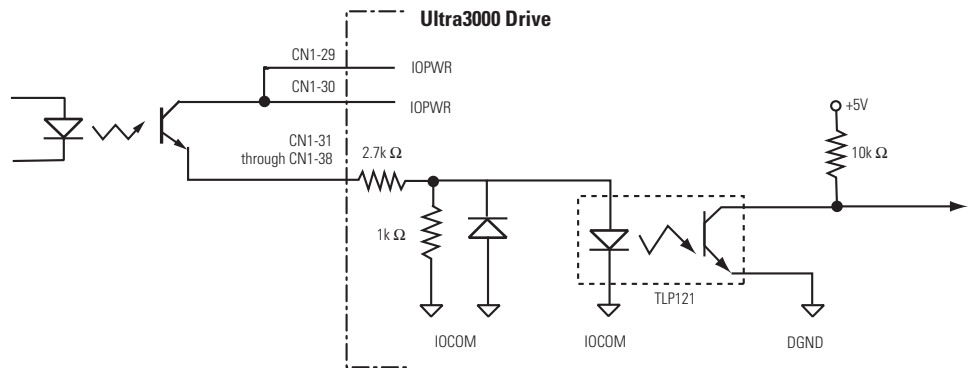

Figure 2.16
Drive Input Connected to NPN Transistor

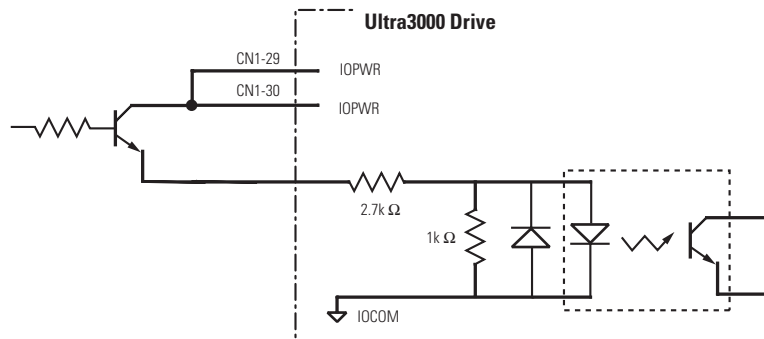

Figure 2.17
Drive Input Connected to NPN Transistor using Switch/Relay

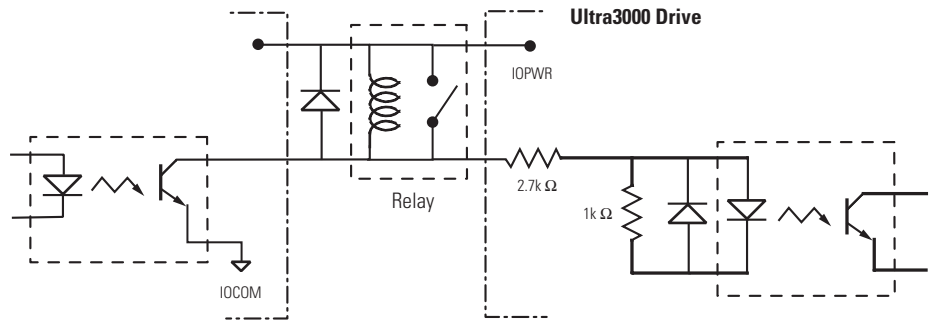

Figure 2.18
Drive Input Connected to NPN Transistor using Opto-Isolator

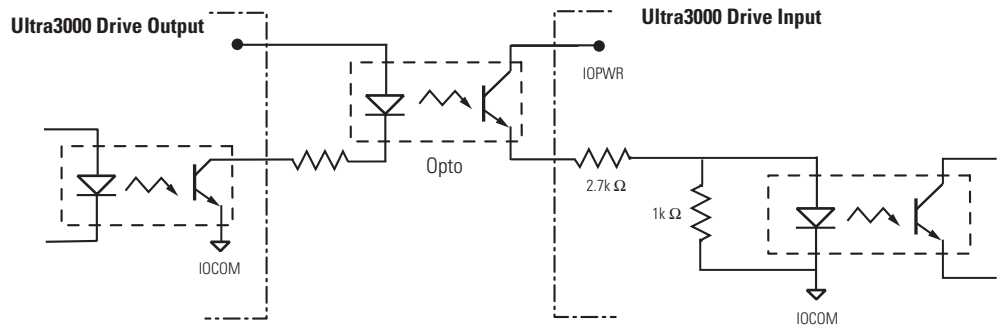

Figure 2.19
Drive Input Connected to another Ultra3000 Output

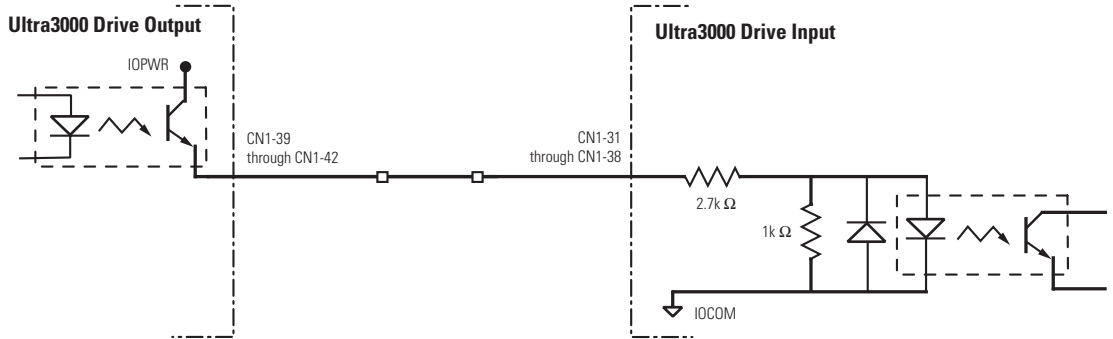
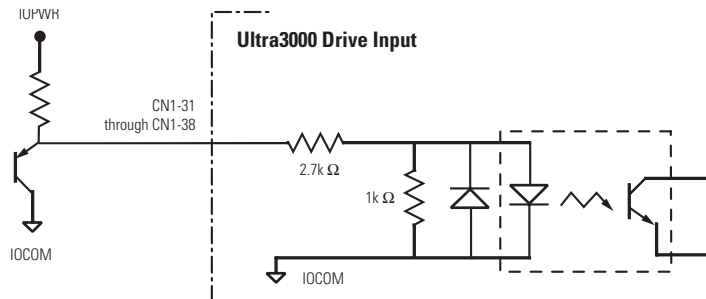

Figure 2.20
Drive Input Connected to PNP Transistor



Input Interface Examples for Active Low Inputs

Figure 2.21
Drive Input Connected to Normally Closed Switch

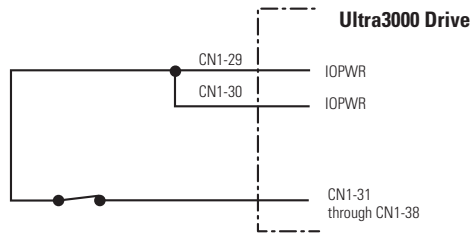

Figure 2.22
Drive Input Connected to Opto-Isolator

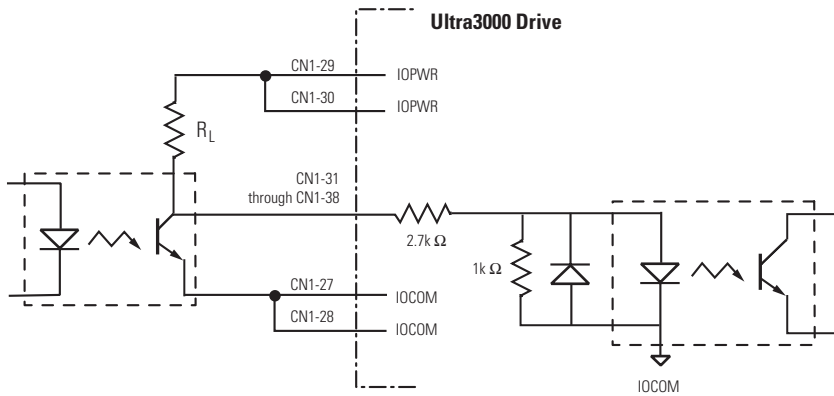

Figure 2.23
Drive Input Connected to NPN Transistor

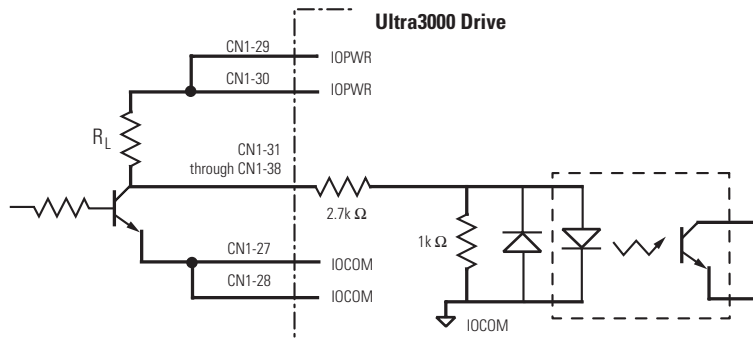
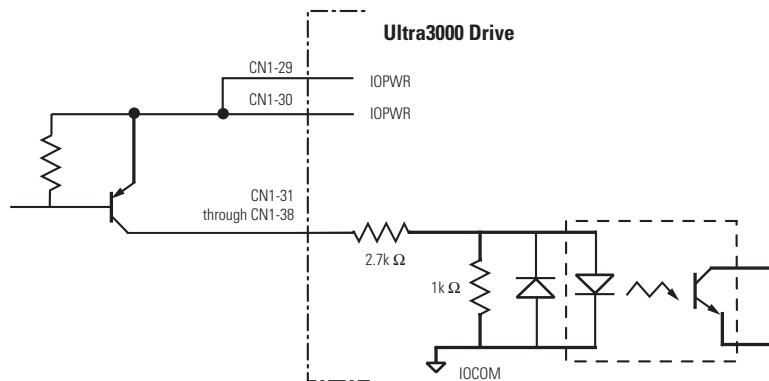

Figure 2.24
Drive Input Connected to PNP Transistor



Digital Outputs

There are four opto-isolated transistor outputs that can be configured for a variety of functions through software. Additionally, the drive has a relay output with normally open contacts. On SERCOS drives, the relay output is dedicated as a Brake output, where closed contacts release a motor brake.

The configuration of the transistor outputs is shown in Figure 2.25, and the configuration of the relay output is shown in Figure 2.26.

IMPORTANT

There is no overload protection on the transistor outputs.

Figure 2.25
Transistor Output Hardware Configuration

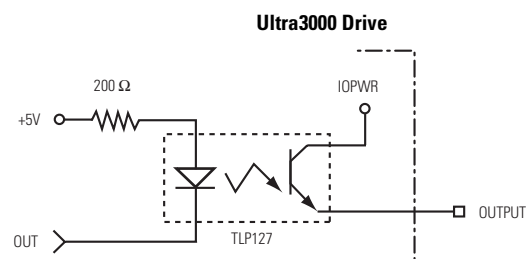

The following table provides a description of the digital output specifications.

Parameter	Description	Minimum	Maximum
ON State Current	Current flow when the output transistor is ON	—	50 mA
OFF State Current	Current flow when the output transistor is OFF	—	0.1 mA
ON State Voltage	Voltage across the output transistor when ON	—	1.5V
OFF State Voltage	Voltage across the output transistor when OFF	—	50V

Figure 2.26
Relay Output Hardware Configuration

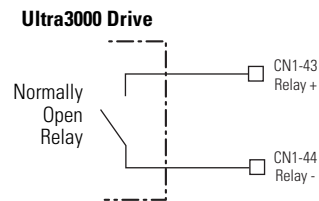

The following table provides a description of the relay output specifications.

Parameter	Description	Minimum	Maximum
ON State Current	Current flow when the relay is closed	—	1A
ON State Resistance	Contact resistance when the relay is closed	—	1 Ω
OFF State Voltage	Voltage across the contacts when the relay is open	—	30V

Drive Output Interface Examples

Figure 2.27
Drive Output Connected to an Opto-Isolator

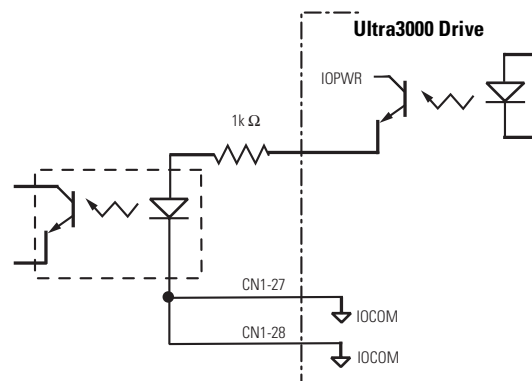

Figure 2.28
Drive Output Connected to an LED Indicator

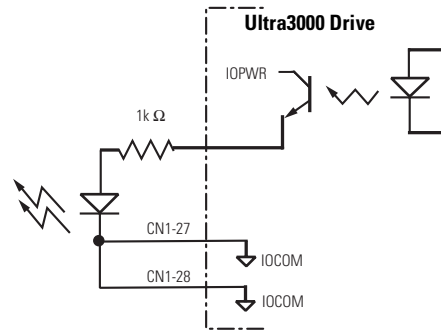

Figure 2.29
Drive Output Connected to a Resistive Load

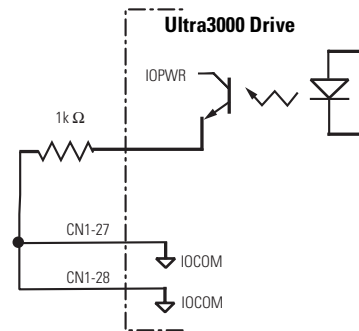

Figure 2.30
Drive Output Connected to a Switch/Relay

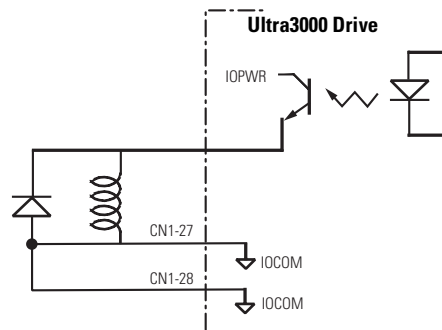

Figure 2.31
Drive Output Connected to an Active Low Input using a Switch/Relay

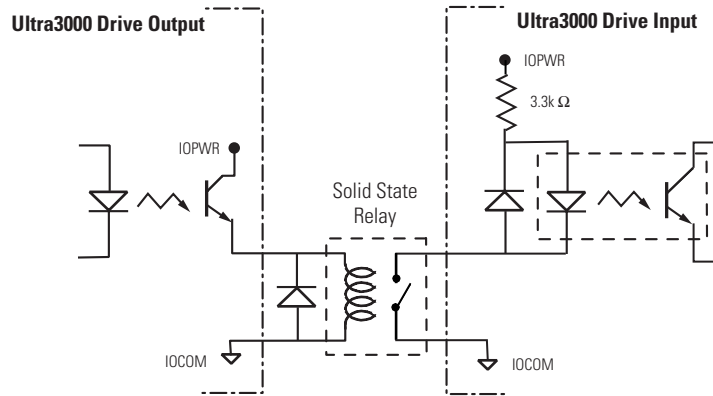

Figure 2.32
Drive Output Connected to an Active Low Input using an Opto-Isolator

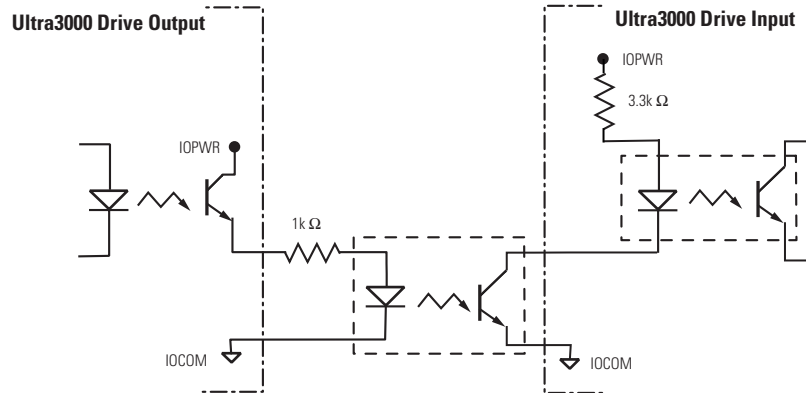
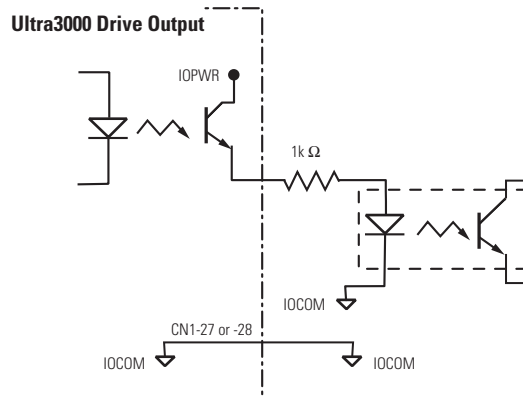

Figure 2.33
Drive Output Connected to an Active High (sinking) Input



Analog COMMAND Input

The COMMAND input to the drive can provide a position, velocity, or current command signal. A 14 bit A/D converter digitizes the signal. The configuration of the input is shown in Figure 2.34.

Figure 2.34
Analog COMMAND Input Configuration

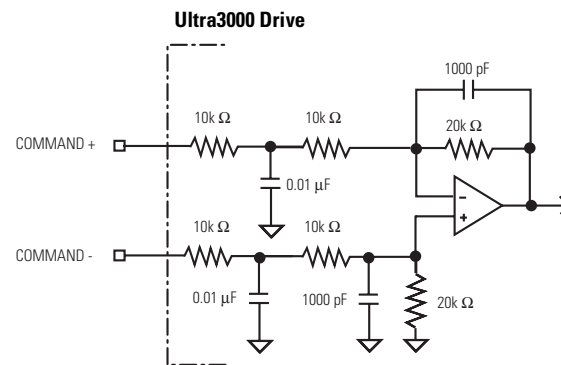

The following table provides a description of the analog COMMAND input specifications.

Parameter	Description	Minimum	Maximum
Resolution	Number of states that the input signal is divided into which is $2^{\text{(to the number of bits)}}$.	14 bits	—
Input Impedance	Open circuit impedance measured between the + and - inputs.	20 kΩ	—
Input Signal Range	Voltage applied to the input	-10V	+10V
Offset Error	Deviation from the correct value expected from analog-to-digital conversion when 0V is applied to the input.	—	50 mV
Gain Error	Deviation of the transfer function from unity gain, expressed in a percent of full scale.	—	1%
Propagation Delay	Delay from the input to the firmware-accessible registers.	—	100 μS

Analog ILIMIT Input

The ILIMIT input specifies to the drive if the drive output current should be limited. If the ILIMIT input is not connected, current is not limited. A 10 bit A/D converter digitizes the signal. The configuration of the ILIMIT input is shown in Figure 2.35.

The input range is 0 to 10V, and the drive current is limited inversely proportional to the input voltage. A +10V input corresponds to no current limiting, and a 0V input prevents any drive current.

Figure 2.35
Analog ILIMIT Input Configuration

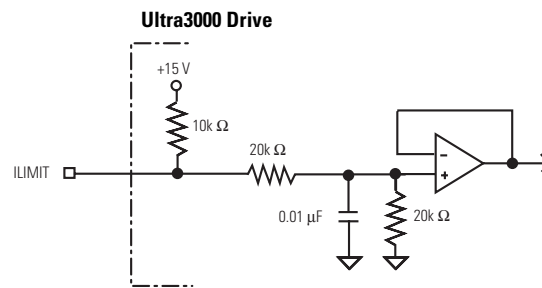

The following table provides a description of the analog ILIMIT input specifications.

Parameter	Description	Minimum	Maximum
Resolution	Number of states that the input signal is divided into which is $2^{\text{(to the number of bits)}}$	10 bits	—
Input Impedance	Open circuit impedance measured between the input and analog common.	10 kΩ	—
Input Signal Range	Voltage applied to the input	0V	+10V
Offset Error	Deviation from the correct value expected from analog-to-digital conversion when 0V is applied to the input.	—	50 mV
Gain Error	Deviation of the transfer function from unity gain, expressed in a percent of full scale.	—	1%
Propagation Delay	Delay from the input to the firmware-accessible registers.	—	100 μS

Analog Output

The Ultra3000 includes a single analog output (not supported on the SERCOS models) that can be configured through software to represent drive variables. Figure 2.36 shows the configuration of the analog output.

Figure 2.36
Analog Output Configuration

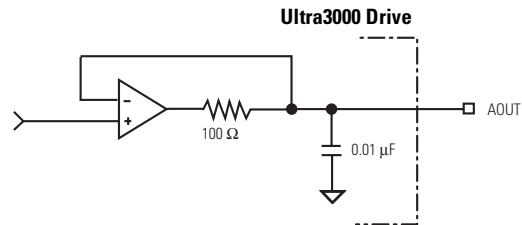

IMPORTANT

Output values can vary during power-up until the specified power supply voltage is reached.

The following table provides a description of the analog output specifications.

Parameter	Description	Minimum	Maximum
Resolution	Number of states that the output signal is divided into, which is $2^{\text{(to the number of bits)}}$.	8 Bits	—
Output Current	Current capability of the output.	-2 mA	+2 mA
Output Signal Range	Range of the output voltage.	-10V	+10V
Offset Error	Deviation when the output should be at 0V.	—	500 mV ¹
Gain Error	Deviation of the transfer function from unity gain, expressed in a percent of full scale.	—	10% ¹
Bandwidth	Frequency response of the analog output	50 Hz	—

¹ The offset and gain errors of the analog output can be corrected for an application using Ultraware scale and offset settings.

Understanding Motor Encoder Feedback Specifications

The Ultra3000 can accept motor encoder signals from the following types of encoders:

- Incremental encoders with TTL outputs, with or without Hall signals
- Sine/Cosine encoders, with or without Hall signals
- Intelligent absolute encoders
- Intelligent high-resolution encoders
- Intelligent incremental encoders

Note: The intelligent absolute, high-resolution, and incremental encoders are available only in Allen-Bradley motors.

AM, BM, and IM Inputs

AM, BM, and IM Input encoder signals are filtered using analog and digital filtering. The inputs also include illegal state change detection. Refer to Figure 2.37 for a schematic of the AM, BM, and IM inputs.

Figure 2.37
Schematic of the Motor Encoder Inputs

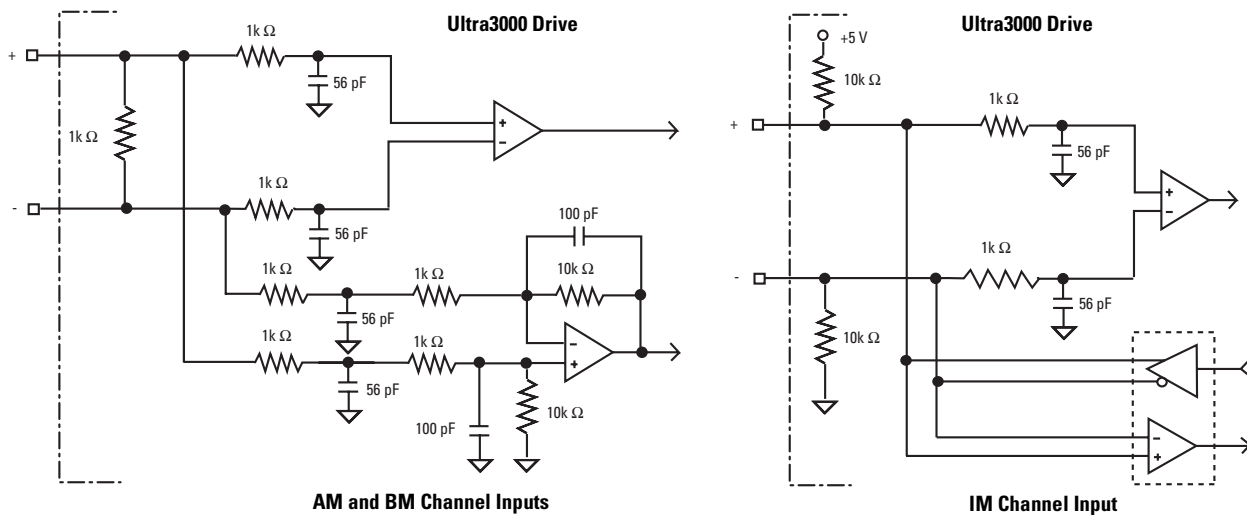

The Ultra3000 supports both TTL and Sine/Cosine encoders. The following table provides a description of the AM, BM, and IM inputs for TTL encoders.

Parameter	Description	Minimum	Maximum
AM, BM, and IM ON State Input Voltage	Input voltage difference between the + input and the - input that is detected as an ON state.	+1.0V	+7.0V
AM, BM, and IM OFF State Input Voltage	Input voltage difference between the + input and the - input that is detected as an OFF state.	-1.0V	-7.0V
Common Mode Input Voltage	Potential difference between any encoder signal and logic ground.	-7.0V	+12.0V
DC Current Draw	Current draw into the + or - input.	-30 mA	30 mA
AM, BM Input Signal Frequency	Frequency of the AM or BM signal inputs. The count frequency is 4 times this frequency, since the circuitry counts all four transitions.	—	2.5 MHz
IM Pulse Width	Pulse width of the index input signal. Since the index is active for a percentage of a revolution, the speed will determine the pulse width.	125 nS	—
AM / BM Phase Error, 2.5 MHz Line Frequency	Amount that the phase relationship between the AM and BM inputs can deviate from the nominal 90°.	-22.5°	+22.5°
AM / BM Phase Error, 1 MHz Line Frequency	Amount that the phase relationship between the AM and BM inputs can deviate from the nominal 90°.	-45°	+45°

The following table provides a description of the AM and BM inputs for Sine/Cosine encoders.

Parameter	Description	Minimum	Maximum
Sine and Cos Input Signal Frequency	Frequency of the Sine or Cos signal inputs.	—	100 kHz
Sine and Cos Input Voltage	Peak-to-peak input voltages of the Sine and Cos inputs	0.5V (p-p)	2.0V (p-p)

Hall Inputs

The Ultra3000 can use Hall signals to initialize the commutation angle for sinusoidal commutation. Hall signals must be single-ended and can be either open collector type or TTL type. Figure 2.38 shows the configuration of the Hall inputs. If the motor does not have Hall signals, the drive can be configured through software to ignore the signals.

Figure 2.38
Hall Input Configuration

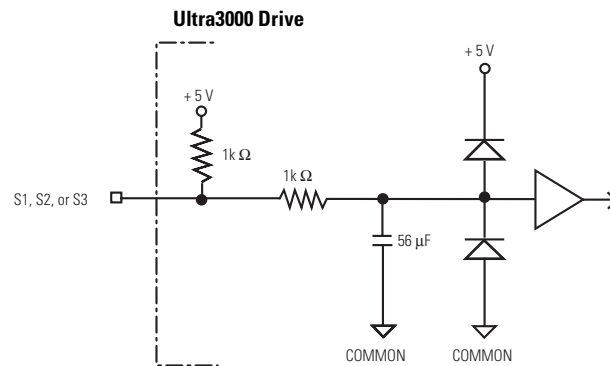

Thermostat Input

The Ultra3000 can monitor a thermostat signal from a motor and will generate a fault if the motor overheats. Figure 2.39 shows the configuration of the thermostat input. Figure 2.40 on page 2-43 shows a typical connection to a motor with a normally closed thermostat. The logic is designed so that an open condition will generate a fault. If the motor does not have a thermostat signal, the drive can be configured through software to ignore the signal.

Figure 2.39
Thermostat Input Configuration

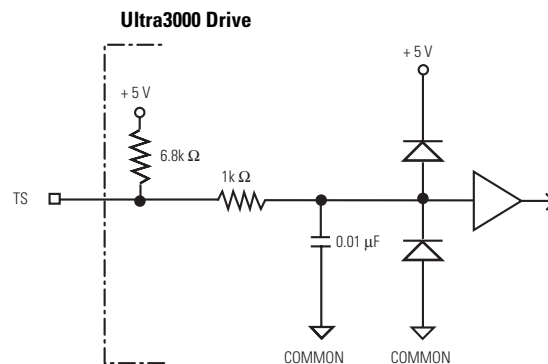
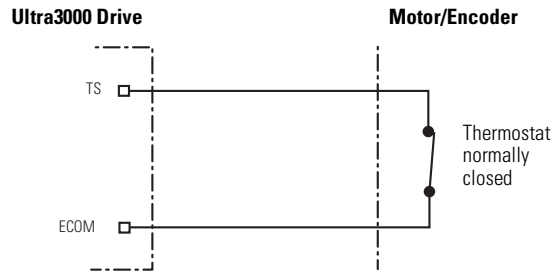

Figure 2.40
Typical Thermostat Connection



+ Limit and - Limit Inputs

The Ultra3000 drive includes integral overtravel limit inputs on the motor encoder connector (CN2). The logic is designed so that an open condition will halt motion in the corresponding direction. The integral limits are configured by the actual motor file and not software programmable. Although typically not for use on standard servo motors, they may be activated for linear motors or other unique applications. Figure 2.41 shows the configuration of the +Limit and -Limit inputs. Figure 2.42 shows a typical connection to a motor with integral limit switches.

Figure 2.41
+ Limit and - Limit Input Configuration

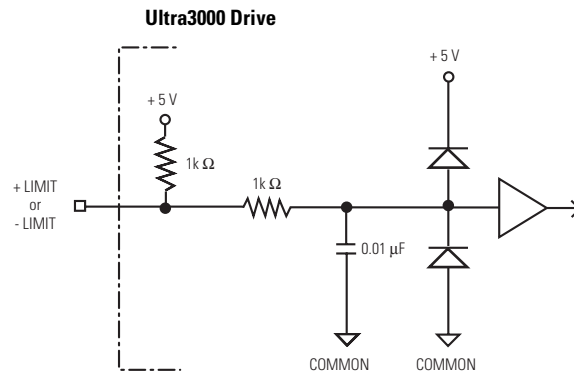
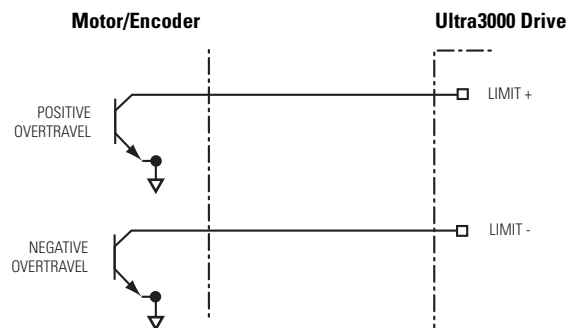

Figure 2.42
Typical + Limit and - Limit Connection



Encoder Phasing

For proper motor commutation and control, it is important that the motor feedback signals are phased properly. The drive has been designed so that a positive current applied to a motor will produce a positive velocity and increasing position readings, as interpreted by the drive. Additionally, if Hall signals are used to initialize the commutation angle, the Hall signals must sequence properly and the phase relationship to the motor back-EMF signals must be understood. Figure 2.43 shows the proper sequencing of the Hall signals when positive current is applied to the motor. If the Hall signals are out of phase with the back-EMF signals, the drive can be configured through software to compensate for the phase offset, as long as the sequencing of the Hall signals is correct. Figure 2.44 shows an example where the Hall signals have an offset of 60 degrees.

Figure 2.43
Sequencing and Phasing of the Hall Signals

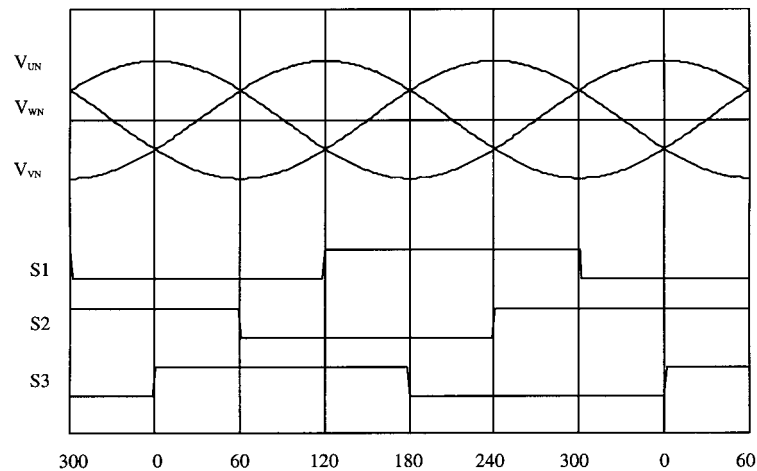

Figure 2.44
Sequencing and Phasing of the Hall Signals (60° Hall Offset Example)

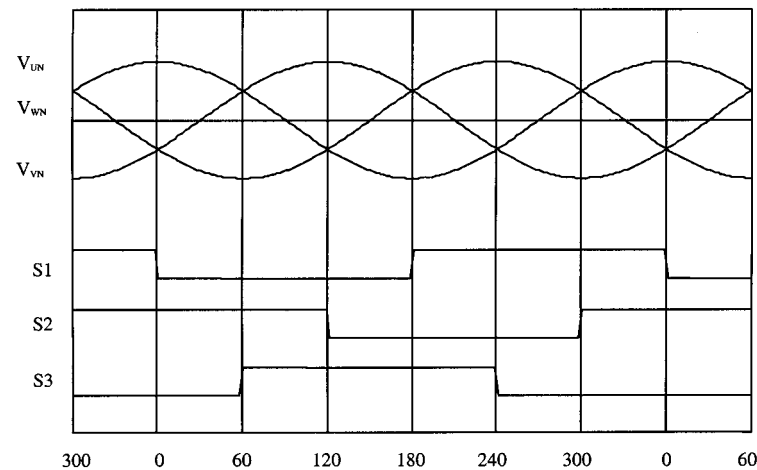

Figure 2.45 shows the proper phasing of TTL A/B encoder signals when positive current is applied.

Figure 2.45
Phasing of TTL A/B Encoder Signals

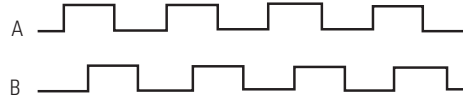
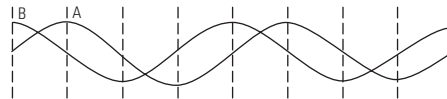

Figure 2.46 shows the proper phasing of Sine/Cosine encoder signals when positive current is applied.

IMPORTANT

Notice that the Sine/Cosine encoder signal phasing is different than the phasing of the TTL encoders.

Figure 2.46
Phasing of Sine/Cosine Encoder Signals



Motor Encoder Connection Diagram

Figure 2.47 shows a typical wiring diagram of a motor feedback cable. If the thermostat, limit, or Hall signals are not available, no connections are required, but the drive must be configured through software to ignore these signals. Refer to *Appendix B* for specific Ultra3000 drive/motor interconnect diagrams.

Figure 2.47
Drive/Motor Wiring Diagram

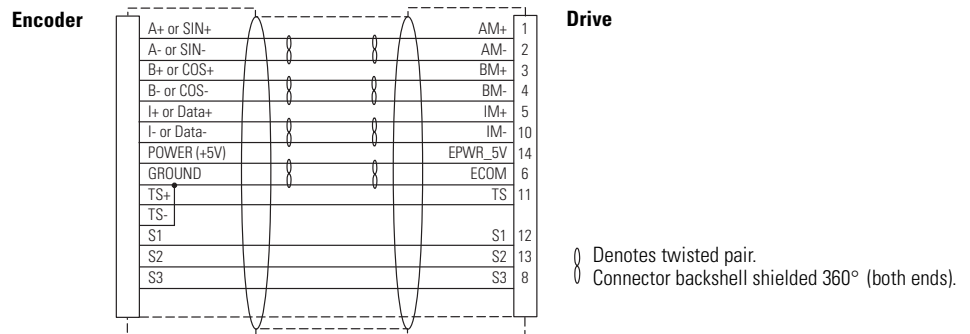

IMPORTANT

Total resistance of the wiring for +5V encoder power and ground connections between the drive and motor must be less than 1.4 ohms.

Understanding Motor Feedback Signals and Outputs

The Ultra3000 is compatible with motors equipped with both incremental A quad B or high resolution (Stegmann Hiperface[®]) SIN/COS encoders.

The buffered motor encoder outputs use RS-485 differential drivers and have a maximum signal frequency of 2.5 MHz. The drivers can drive a 2V differential voltage into a 100 ohm load. Use the block diagram below to follow the motor encoder input through CN2 to the buffered and unbuffered outputs on CN1.

Figure 2.48
Motor Encoder Outputs

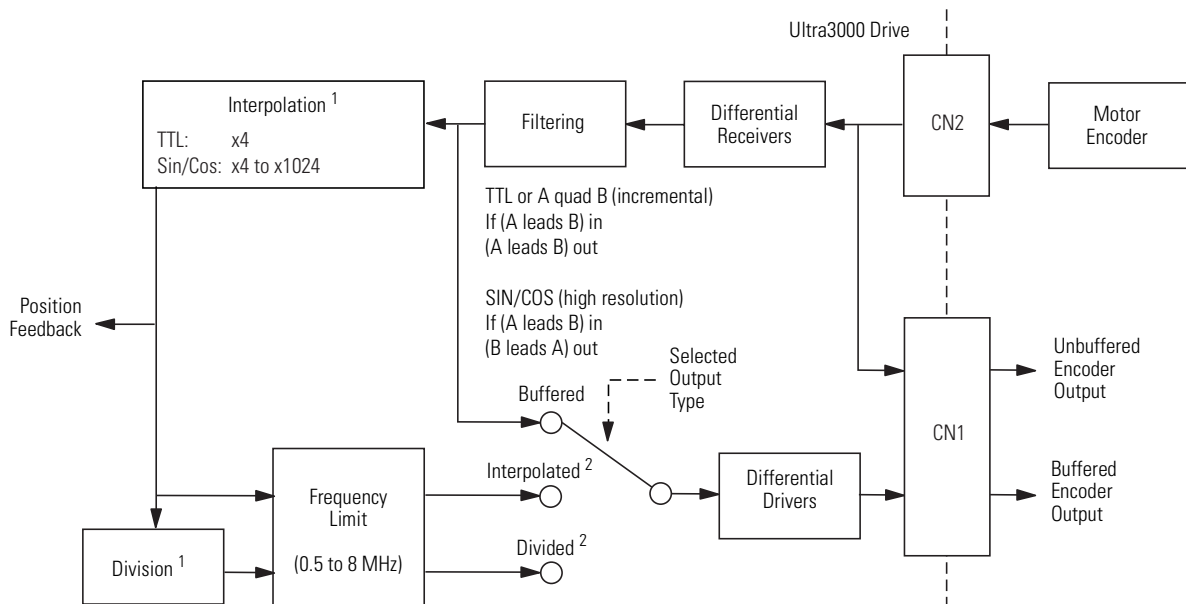

¹ Interpolation and division operations are performed in firmware and the resulting output frequency is updated at 250 μ s intervals.

² Interpolated and divided output not available on SERCOS drives.

Unbuffered Encoder Outputs

The unbuffered outputs available from the drive (CN1-10 through -15) are tied directly to the incoming (incremental or high resolution) encoder signals (CN2-1 through -6). The unbuffered outputs are not filtered or conditioned.

Incremental Encoder Output

Incremental encoder counts are generated in the drive by counting the (high to low and low to high) transitions of the incoming A and B encoder signals. In Figure 2.49 the channel A signal has two transitions, as does the channel B signal, which results in x4 interpolation (4 transitions/line equals 4 counts/line). So, for example, typical 2000 line/rev encoder output becomes 8000 counts/rev in the drive. Counts are not directly available at the encoder outputs, only the A quad B representation.

Figure 2.49
Incremental Encoder Counts

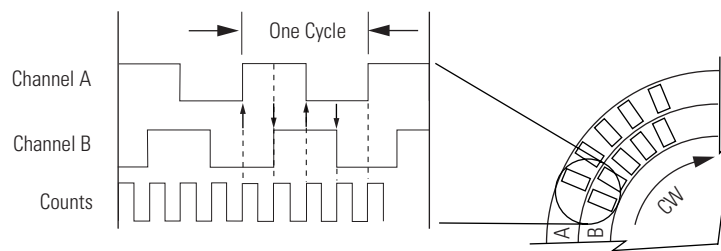

The incremental buffered outputs available from the drive (CN1-16 through -21) are software selectable as follows:

- **Buffered Outputs** are a filtered representation of the original incoming encoder (CN2) signals. Buffered outputs have the same number of cycles/rev as found on CN2.
- **Interpolated Outputs** are the same as buffered outputs when using an incremental encoder. The only interpolation performed on an A quad B signal is the drive's internal counting of transitions (4 counts/line). Because counts are not available outside the drive, selecting this in software is the same as selecting buffered (as described above).
- **Divided Outputs** are the same as buffered outputs, except when divided is selected in the software, the lines/rev are then reduced by the value of the divisor chosen in the software (as shown in the figure below).

Figure 2.50
Incremental Encoder Divided

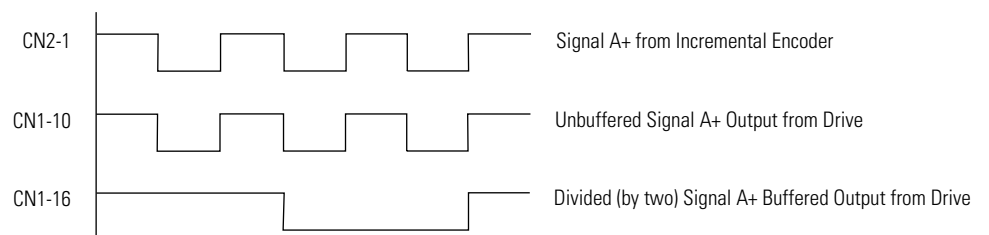

High Resolution Encoder Output

When the incoming encoder feedback on CN2 is a high resolution (SIN/COS) signal, the drive is capable of generating more than just 4 counts/cycle (as with incremental encoders). The Ultra3000 drive is capable of breaking the SIN/COS encoder signals into as many as 1024 counts/cycle. So, for example, a 1024 cycle/rev SIN/COS encoder can result in 1024 x 1024 (high resolution) counts/rev.

Figure 2.51
Absolute High Resolution Encoder Signals

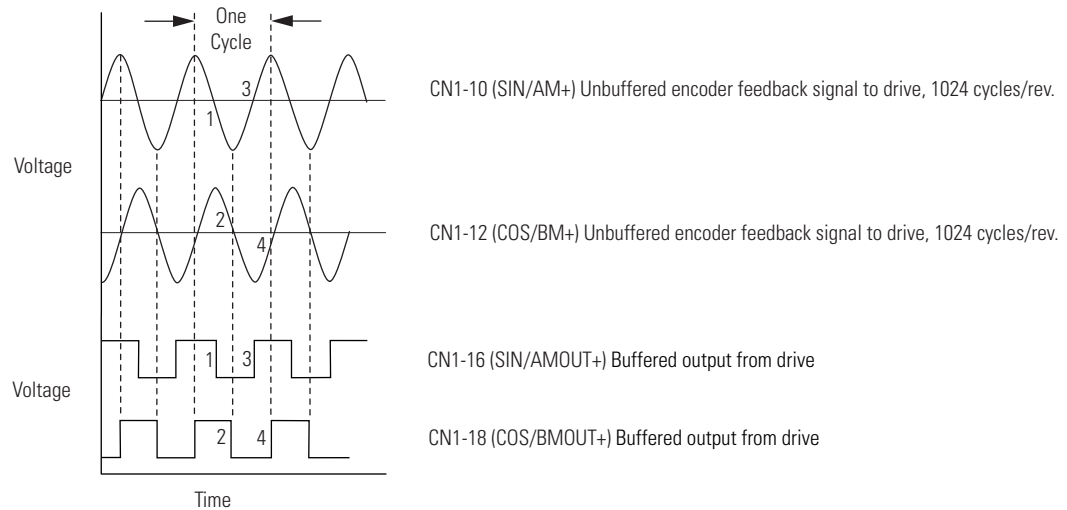

The high resolution buffered outputs available from the drive (CN1-16 through -21) are software selectable as follows:

- **Buffered Outputs** are conditioned SIN/COS signals resulting in a square wave (A quad B) signal (refer to Figure 2.51). This signal will have the same number of cycles/rev as the incoming SIN/COS encoder signals found on CN2.
- **Interpolated Outputs** are square wave (A quad B) signals reflecting the interpolation value chosen in software. The minimum interpolation value allowed is $\times 4$, which gives the same output as selecting buffered (as described above).
- **Divided Outputs** are the result of a divisor (selected in software) and an interpolation value (also selected in software). For example, with an interpolation value of $\times 8$ and a divisor of 2, the CN1 buffered output will be the ($\times 4$) square wave representation of the original incoming SIN/COS signal from CN2.

IMPORTANT

The interpolation value selected in software is what the drive uses internally to close the feedback loops regardless of any divisor value chosen to condition the signals present on CN1.

Figure 2.52
Interpolated and Divided Absolute High Resolution Encoder Counts

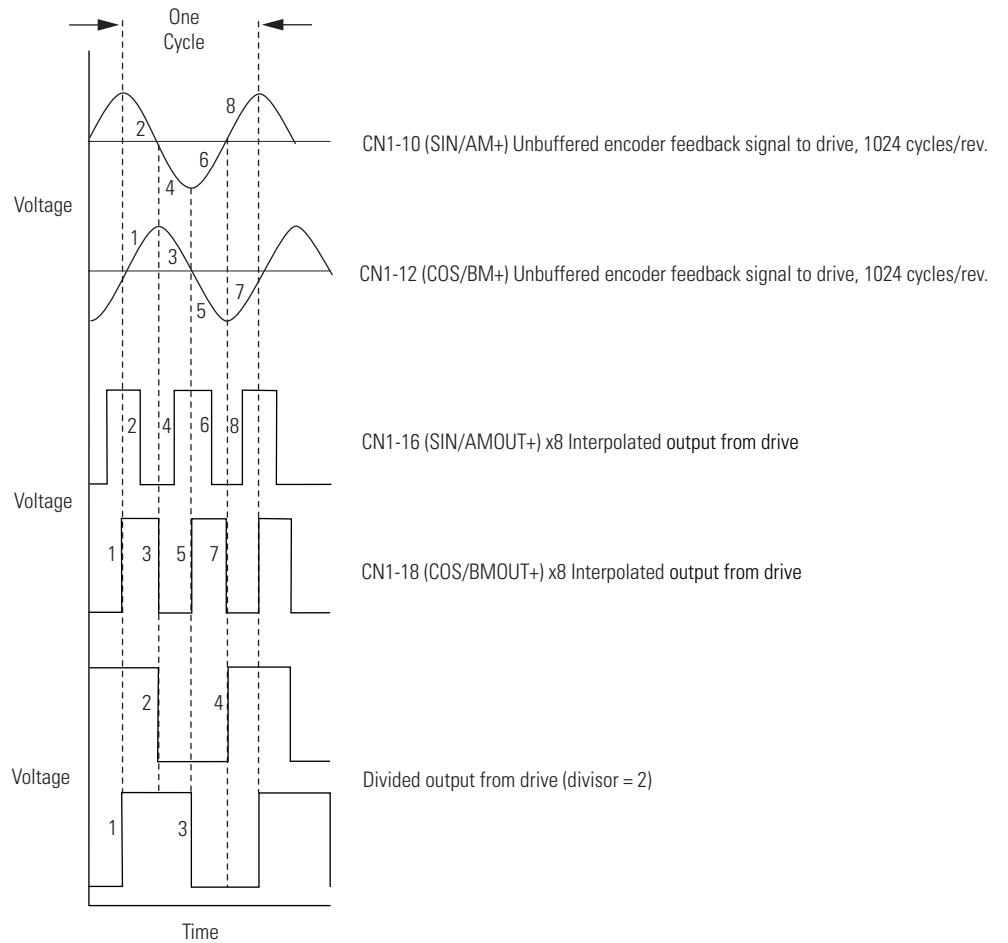

Understanding Auxiliary Encoder Feedback Specifications

The Ultra3000 can accept an auxiliary encoder signal of the following types.

Figure 2.53
Auxiliary Encoder Input Signal Types

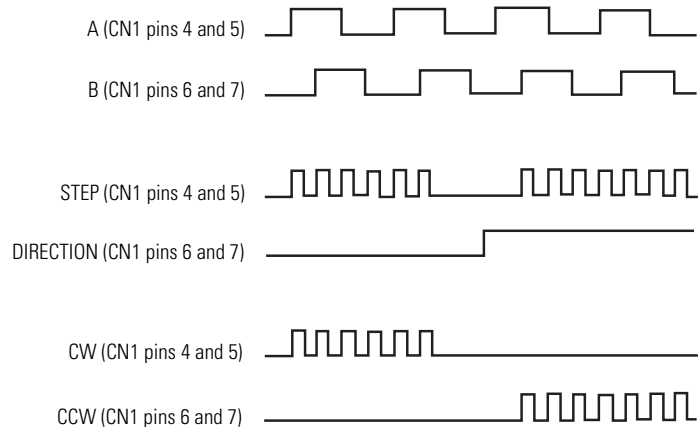
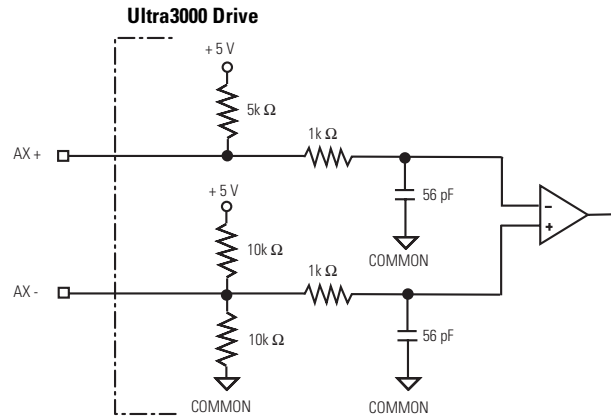

Figure 2.54 shows the configuration of the AX Auxiliary Encoder Input channel. The BX and IX channels have the same configuration.

Note: CW pulses are only counted when the CCW input is low, and CCW pulses are only counted when the CW input is low.

Figure 2.54
Auxiliary Encoder Input Configuration



Note: For single-ended connections, the negative terminals (CN1 pins 5 and 7) should be left disconnected, and the signal connections should be made to CN1 pins 4 and 6.

The following table provides a description of the auxiliary encoder interface.

Parameter	Description	Minimum	Maximum
ON State Input Voltage	Input voltage difference between the + input and the - input that is detected as an ON state.	+1.0V	+7.0V
OFF State Input Voltage	Input voltage difference between the + input and the - input that is detected as an OFF state.	-1.0V	-7.0V
Common Mode Input Voltage	Voltage between an input and logic ground.	-7.0V	+12.0V
Signal Frequency	Frequency of the AX or BX signal inputs. Count frequency is 4 times this frequency for A/B type inputs, and equal to this frequency for Step/Dir and CW/CCW type inputs.	—	2.5 MHz
Pulse Width	Time interval that a Step/Dir type input or CW/CCW type input must remain in a single state for detection.	200 nS	—
Setup Time	Time interval that the Direction, CW, or CCW must be stable before the corresponding Step, CCW, or CW signal changes state.	200 nS	—

5V Auxiliary Encoder Power Supply

All Ultra3000 drives supply 5V dc for the operation of an auxiliary encoder. The following table provides a description of the auxiliary encoder power supply.

Parameter	Description	Minimum	Maximum
Output Voltage	Voltage range of the external power supply for proper operation of an auxiliary encoder.	4.75V	5.25V
Output Current	Current draw from the external power supply for the auxiliary encoder.	—	250 mA

Pin	Signal	Description
CN1-1	EPWR	Auxiliary Encoder Power Out (+5V)
CN1-2	ECOM	Common

IMPORTANT

The internal 5V dc power supply has a resettable fuse that opens at 3 amps and automatically resets itself when the current falls below 3 amps. There are no internal fuses requiring replacement.

Understanding the Serial Interface

The Ultra3000 includes one serial port that implements the standard NRZ asynchronous serial format, and supports RS-232, RS-422, and RS-485 communication standards.

Standard baud rates include 1,200, 2,400, 4,800, 9,600, 19,200, and 38,400 baud. Data lengths of 7 and 8 bits are supported. Parity settings include odd, even, and none.

The connector pinout dedicates separate pins for the RS-232 and RS-422/ RS-485 signals, so that the communication standard can be changed by just using a different cable. Refer to Figure 2.55 for the serial interface configuration.

Figure 2.55
Serial Interface Configuration

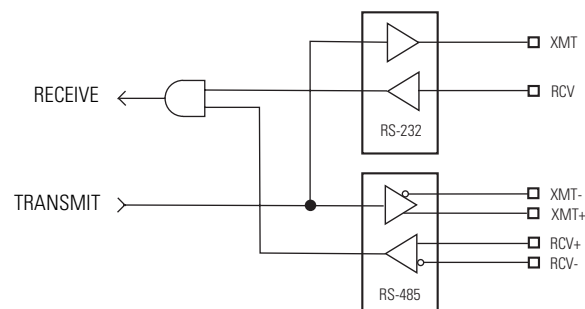

Default Serial Interface Settings

The default setting of the Ultra3000 serial interface is as follows.

Parameter	Default Setting
Baud Rate	38,400
Frame Format	8 Data, No Parity, One Stop
Drive Address	0

Figure 2.56
RS-232 Connection Diagram

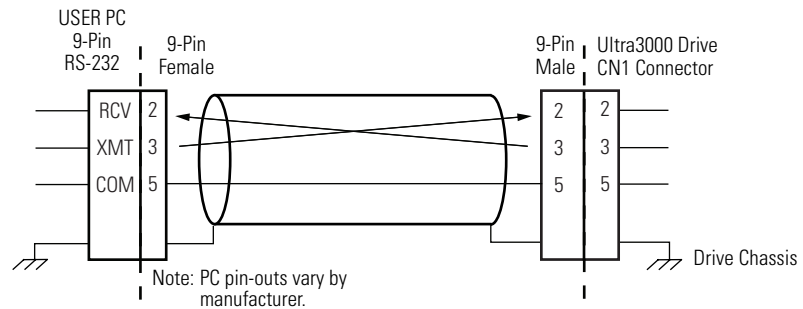

Multiple Axes RS-232 Communications

You can control multiple axes systems with a computer equipped with an RS-232 serial port. An RS-232 serial communication port may be converted to four wire RS-485 communication by attaching an RS-232 to four wire RS-485 converter. The figure below depicts the use of such a device.

Figure 2.57
RS-232 to RS-485 Connection Diagram

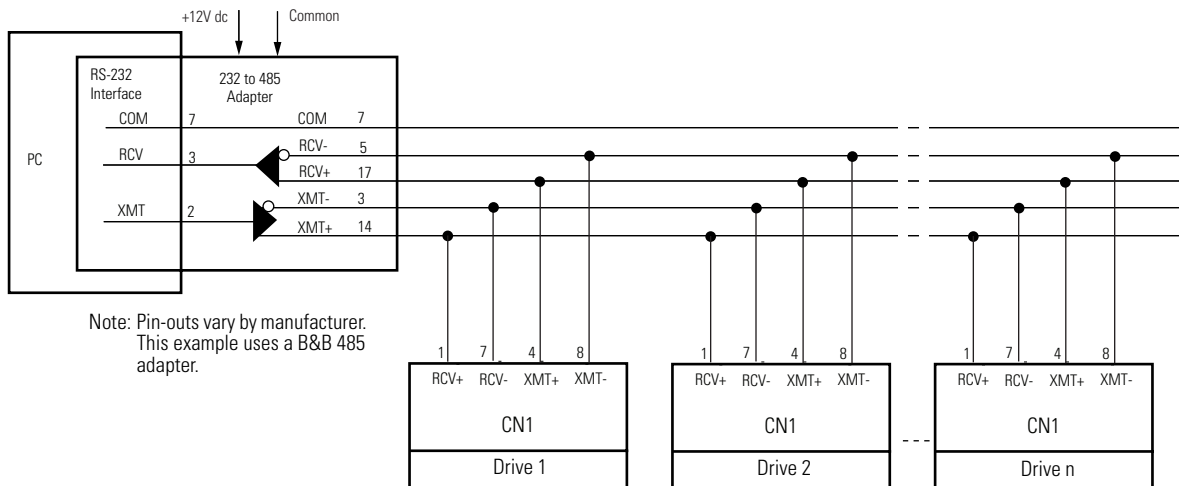

Four-Wire RS-485 Connections

The Ultra3000 uses a variation of the RS-485 standard, known as four-wire RS-485. Four-wire RS-485 uses one differential signal for host to drive transmissions, and another differential signal for drive to host transmissions. The RS-485 standard specifies a single differential signal for transmissions in both directions.

The four-wire RS-485 configuration also allows the host to use a RS-422 interface type. Because the host is driving multiple receivers and receiving from multiple transmitters, RS-422 is limited to multiple axes connections with 10 or less drives. The figure below summarizes the four-wire RS-485, RS-422, and RS-485 standards.

Figure 2.58
RS-485/RS-422 Communication Comparison

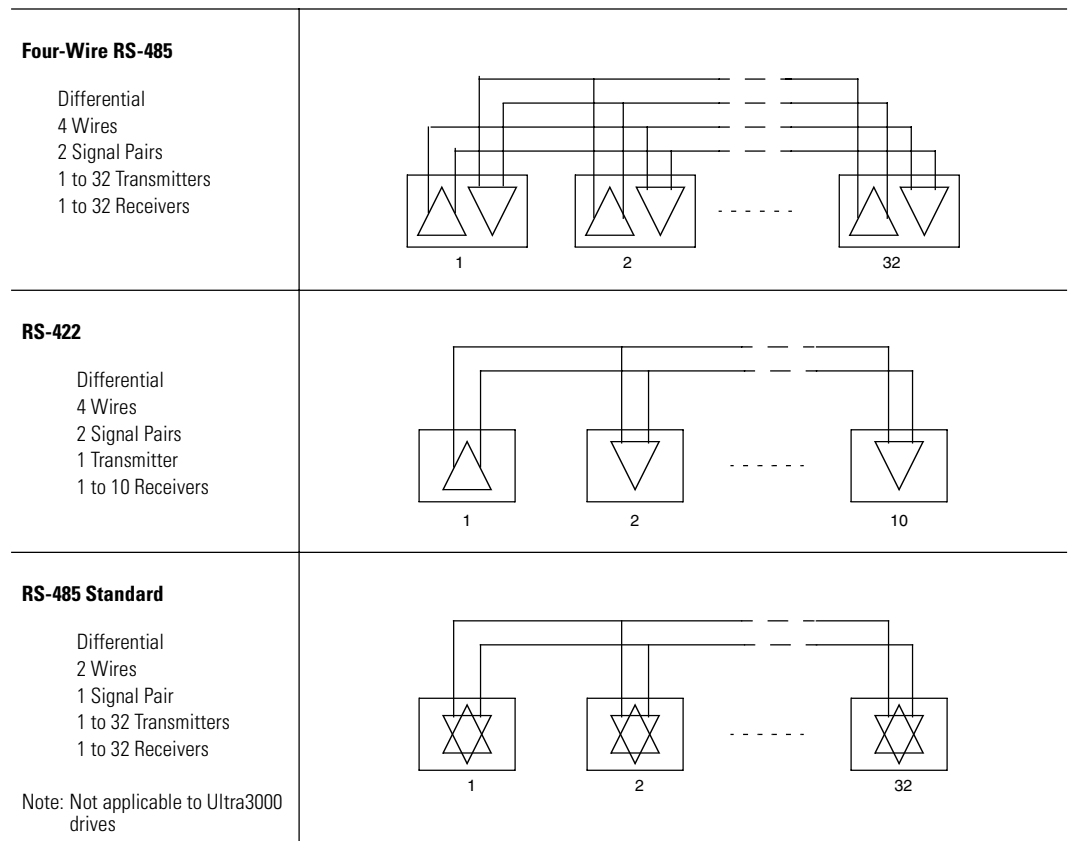

Restoring Drive Communications

The Ultra3000 includes a mechanism for restoring serial communications, in case the drive has unknown serial interface settings or communications cannot be established.

For the first 3 seconds after reset or power-up, the drive listens for messages with the following serial interface settings.

Parameter	Default Setting
Baud Rate	9,600
Frame Format	8 Data, No Parity, One Stop
Drive Address	254

If a message is received during this time, the drive will respond and these settings will be retained until the next reset or power-down, allowing the normal serial interface settings to be determined. If no messages are received during this time, the normal serial interface settings are used.

IMPORTANT

Only one drive should be connected if this mechanism is used, since multiple drives would all respond and the response would be garbled.

Connecting Your Ultra3000

Chapter Objectives

This chapter provides procedures for wiring your Ultra3000 and making cable connections. This chapter includes:

- Understanding Basic Wiring Requirements
- Determining Your Type of Input Power
- Grounding Your Ultra3000
- Power Wiring Requirements
- Connecting Input Power
- Connecting Motor Power and Brakes
- Understanding Shunt Connections
- Understanding Feedback and I/O Cable Connections
- Connecting Your SERCOS Fiber-Optic Cables
- Connecting to a DeviceNet Network

Understanding Basic Wiring Requirements

This section contains basic wiring information for the Ultra3000.

ATTENTION

Plan the installation of your system so that you can perform all cutting, drilling, tapping, and welding with the system removed from the enclosure. Because the system is of the open type construction, be careful to keep any metal debris from falling into it. Metal debris or other foreign matter can become lodged in the circuitry, which can result in damage to components.

IMPORTANT

This section contains common PWM servo system wiring configurations, size, and practices that can be used in a majority of applications. National Electrical Code, local electrical codes, special operating temperatures, duty cycles, or system configurations take precedence over the values and methods provided.

Building Your Own Cables

IMPORTANT

Factory made cables are designed to minimize EMI and are recommended over hand-built cables to ensure system performance.

When building your own cables, follow the guidelines listed below.

- Connect the cable shield to the connector shells on both ends of the cable for a complete 360° connection.
- Use a twisted pair cable whenever possible, twisting differential signals with each other, and single-ended signals with the appropriate ground return.

Refer to *Appendix C* for drive connector kit catalog numbers.

Routing Power and Signal Wiring

Be aware that when you route power and signal wiring on a machine or system, radiated noise from nearby relays, transformers, and other electronic drives, can be induced into motor or encoder feedback, communications, or other sensitive low voltage signals. This can cause system faults and communication problems.

Refer to *Chapter 1* for examples of routing high and low voltage cables in wireways. Refer to *System Design for Control of Electrical Noise* (publication GMC-RM001x-EN-P) for more information.

Determining Your Type of Input Power

On the following pages are examples of typical single-phase and three-phase facility input power wired to single-phase and three-phase Ultra3000 drives.

IMPORTANT

The Ultra3000 (2098-DSD-HVxxx) 460V drives are designed to operate from grounded or ungrounded power configurations. For systems requiring CE or for Ultra3000 (2098-DSD-xxx) 230V drives, the supply must be grounded.

The grounded power configuration allows you to ground your single-phase or three-phase power at a neutral point. Match your secondary to one of the examples and be certain to include the grounded neutral connection.

IMPORTANT

Grounded power (WYE secondary) is the preferred configuration. Examples with delta secondaries (though not preferred) are also shown.

Three-Phase Power Wired to Three-Phase Drives

The following examples illustrate grounded three-phase power wired to three-phase Ultra3000 drives when phase-to-phase voltage is within drive specifications.

Figure 3.1
Three-Phase Power Configuration (WYE Secondary)

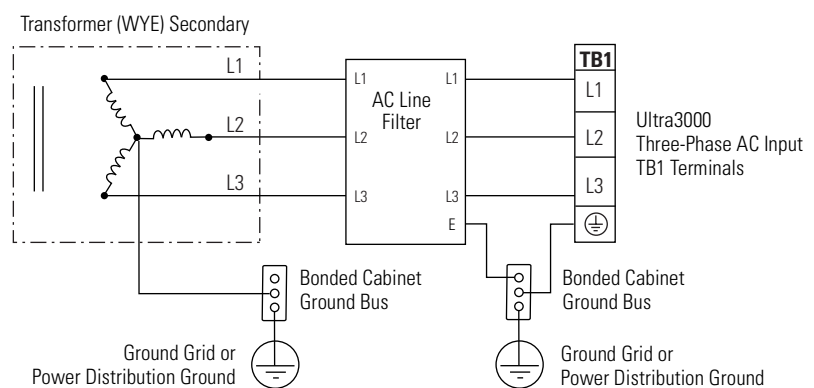

Note: Feeder and branch short circuit protection is not illustrated.

Figure 3.2
Three-Phase Power Configuration (Preferred Delta Secondary)

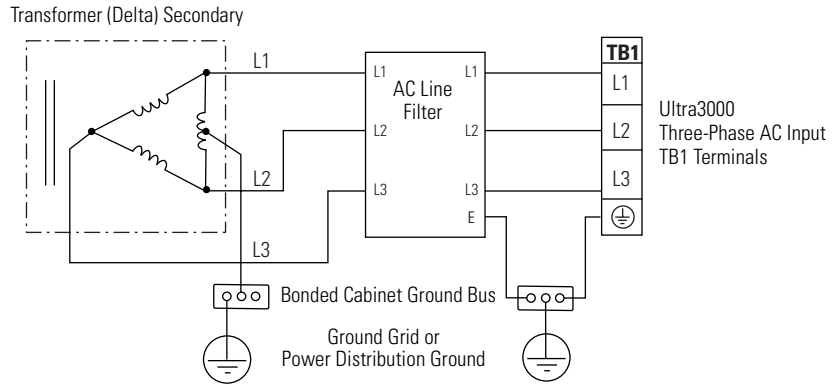

Note: Feeder and branch short circuit protection is not illustrated.

Figure 3.3
Three-Phase Power Configuration (Tolerated Delta Secondary)

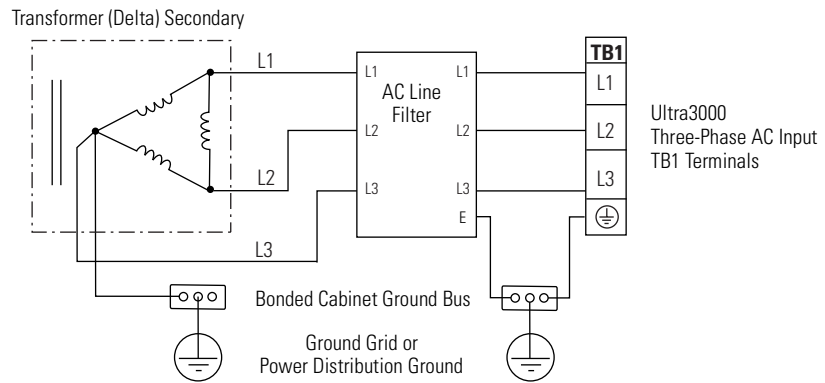

Note: Feeder and branch short circuit protection is not illustrated.

Single-Phase Power Wired to Single-Phase Drives

The following examples illustrate grounded single-phase power wired to single-phase Ultra3000 drives when phase-to-phase voltage is within drive specifications.

Figure 3.4
Single-Phase Grounded Power Configurations

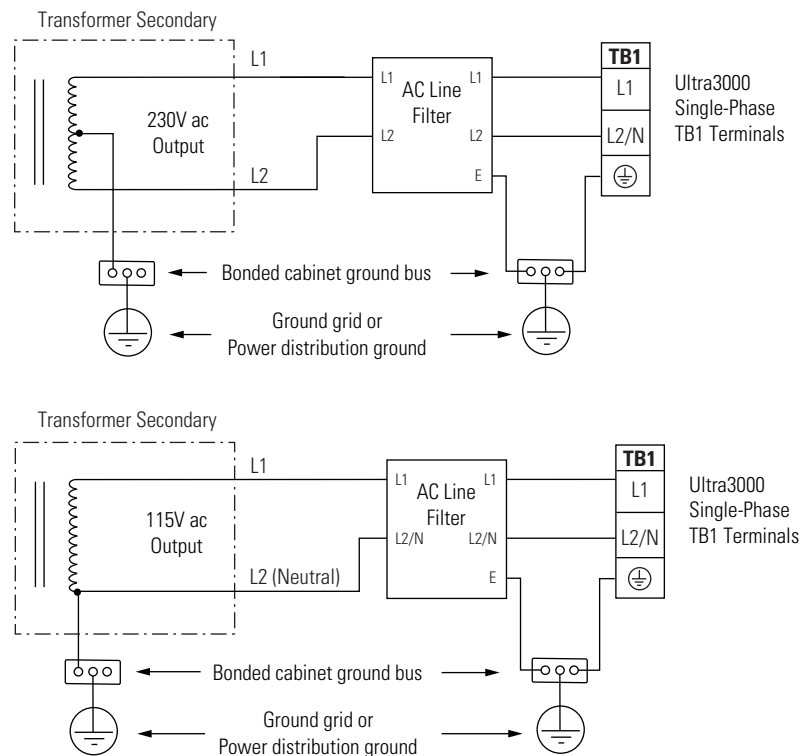

Note: Reducing transformer output will reduce motor speed.

Note: Feeder and branch short circuit protection is not illustrated.

Isolation Transformer in Grounded Power Configurations

When using an isolation transformer, attach a chassis ground wire to the neutral connection. This accomplishes the following:

- Prevents the system from floating and thereby avoids any high voltages that might otherwise occur (e.g., through static).
- Provides a solid earth path for fault conditions.

ATTENTION



If the supply transformer is an auto transformer (not recommended), a chassis earth ground should not be added.

A chassis earth ground should already be included elsewhere in the system, and adding another would create a short.

Three-Phase Power Wired to Single-Phase Drives

The following examples (figures 3.5 and 3.6) illustrate grounded three-phase power wired to single-phase Ultra3000 drives when phase-to-phase voltage is *within* drive specifications.

Figure 3.5
Single-Phase Amplifiers on Three-Phase Power (WYE)

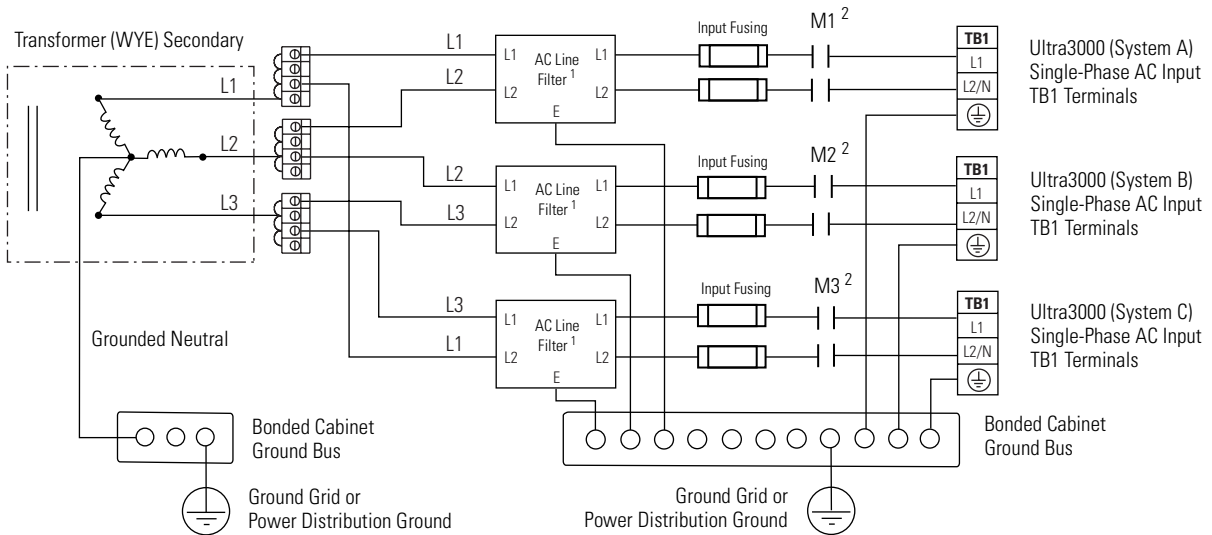

¹ AC line filter is optional, but is required for CE compliance.
² Contactors (M1, M2, and M3) may be optional. For more information refer to *Understanding the Machinery Directive* (publication SHB-900).
 Note: Feeder short circuit protection is not illustrated.

Figure 3.6
Single-Phase Amplifiers on Three-Phase Power (Delta)

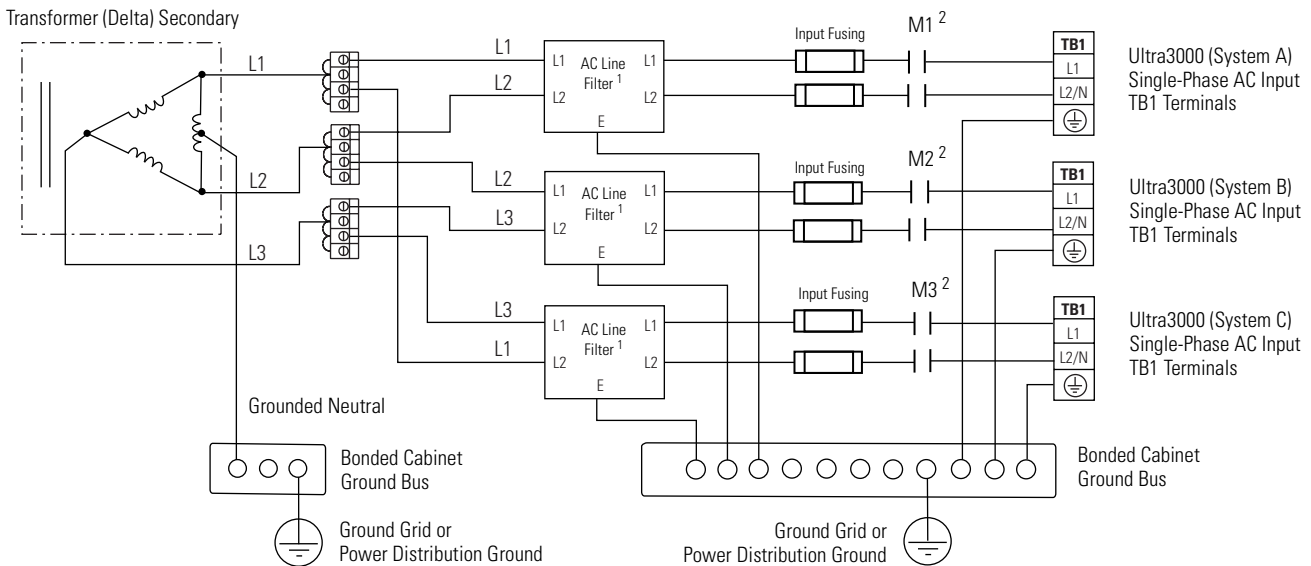

¹ AC line filter is optional, but is required for CE compliance.
² Contactors (M1, M2, and M3) may be optional. For more information refer to *Understanding the Machinery Directive* (publication SHB-900).
 Note: Feeder short circuit protection is not illustrated.

The following examples (figures 3.7 and 3.8) illustrate grounded three-phase power wired to single-phase Ultra3000 drives when phase-to-phase voltage *exceeds* drive specifications.

A neutral must be connected when single-phase drives are attached to a three-phase isolating transformer secondary. It is not necessary that all three-phases be loaded with drives, but each drive must have its power return via the neutral connection.

ATTENTION



Failure to connect the neutral can result in supply voltage swings at the individual loads (i.e., drives). This occurs when the neutral point moves vectorially as a result of load variations normally experienced by the individual drives. The supply voltage swing may cause undervoltage and overvoltage trips on the drives, and the drive can be damaged if the overvoltage limit is exceeded.

Figure 3.7
Single-Phase Amplifiers (One EMC Filter/Drive)

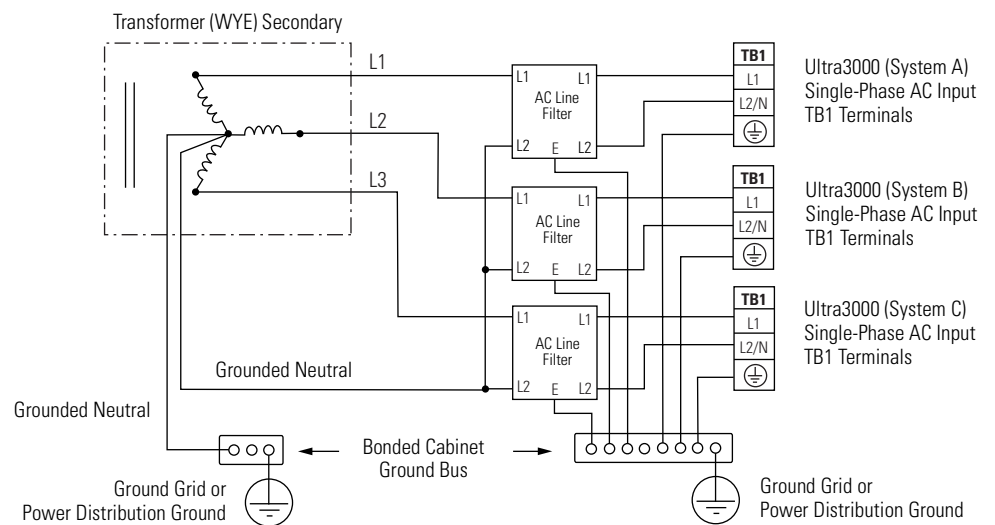

Note: Feeder and branch short circuit protection is not illustrated.

IMPORTANT

Providing an EMC line filter for each drive is the preferred configuration, and required for CE compliance.

If a three-phase line filter is used to feed multiple single-phase drives (not recommended), it is important that the filter include a neutral connection as shown in Figure 3.8. This applies if three-phase is brought directly into the filter (i.e., no isolating transformer present).

Figure 3.8
Single-Phase Amplifiers (One EMC Filter/Multiple Drives)

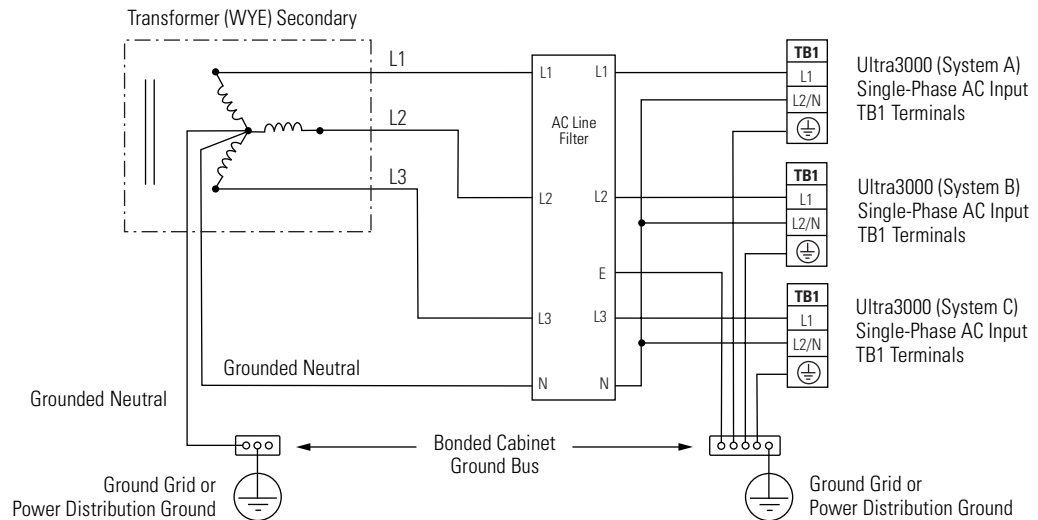

Note: Feeder and branch short circuit protection is not illustrated.

Voiding of CE Compliance

The three-phase and neutral in-line filter applications described above may not be adequate from an EMC aspect for CE compliance. Therefore, EMC validity and CE marking by Rockwell Automation is voided when three-phase and neutral in line filters are used.

ATTENTION



The three-phase isolation transformer and neutral in-line filter applications described in this document have not been tested for EMC by Rockwell Automation, and products used in such installations are not considered CE marked by Rockwell Automation.

If this three-phase isolation transformer and neutral in-line filter application is used, the responsibility for EMC validation lies with the user and CE marking of the system becomes the user's responsibility.

If CE compliance is a customer requirement, single-phase line filters which have been tested by Rockwell and specified for the product should be used. Refer to *AC Line Filters* on page C-3 for catalog numbers.

Grounding Your Ultra3000

All equipment and components of a machine or process system should have a common earth ground point connected to their chassis. A grounded system provides a safety ground path for short circuit protection. Grounding your modules and panels minimize shock hazard to personnel and damage to equipment caused by short circuits, transient overvoltages, and accidental connection of energized conductors to the equipment chassis. For CE grounding requirements, refer to *Meeting CE Requirements* in *Chapter 1*.

IMPORTANT

To improve the bond between the Ultra3000 and subpanel, construct your subpanel out of zinc plated (paint-free) steel.

Grounding Your System to the Subpanel

ATTENTION



The National Electrical Code contains grounding requirements, conventions, and definitions. Follow all applicable local codes and regulations to safely ground your system. Refer to the illustration below for details on grounding your Ultra3000. Refer to *Appendix B* for the power wiring diagram for your Ultra3000 drive.

Figure 3.9
Chassis Ground Configuration (Multiple Ultra3000 Systems on One Panel)

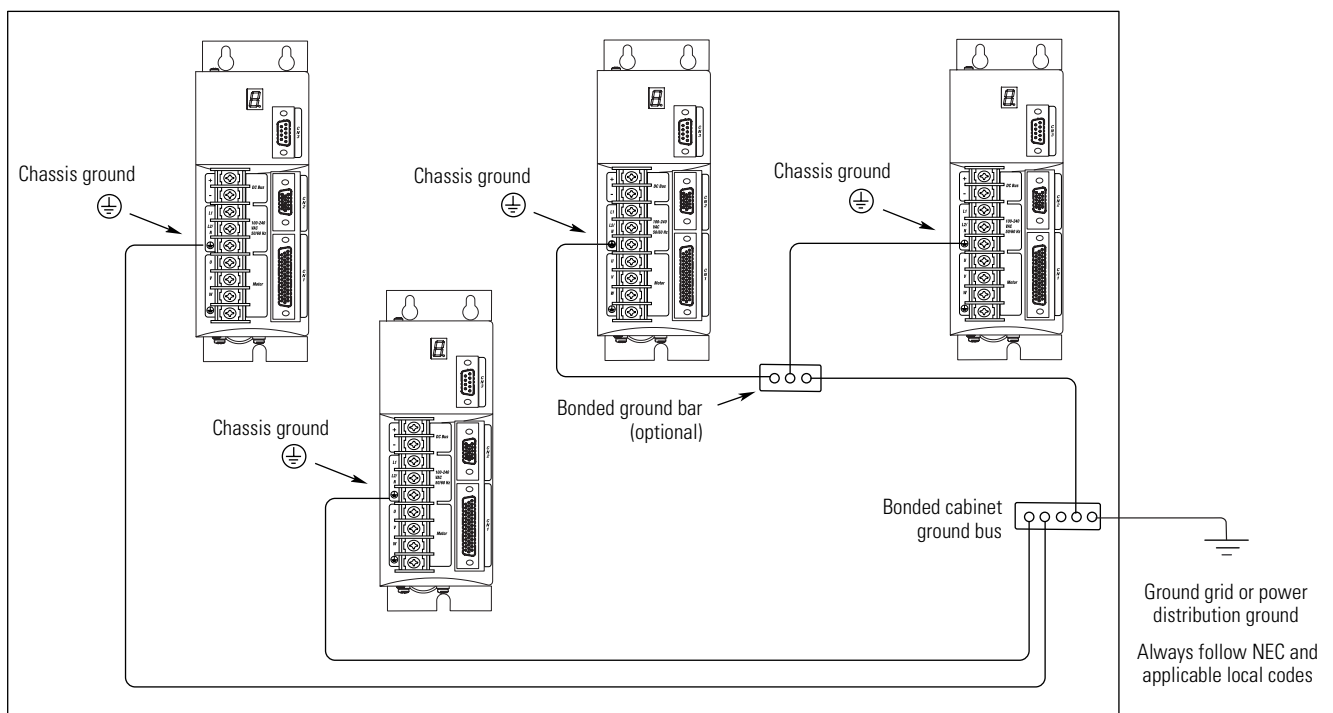

Grounding Multiple Subpanels

To ground multiple subpanels, refer to the figure below.

Note: HF bonding is not illustrated. For HF bonding information, refer to *Bonding Multiple Subpanels* on page 1-12.

Figure 3.10
Subpanels Connected to a Single Ground Point

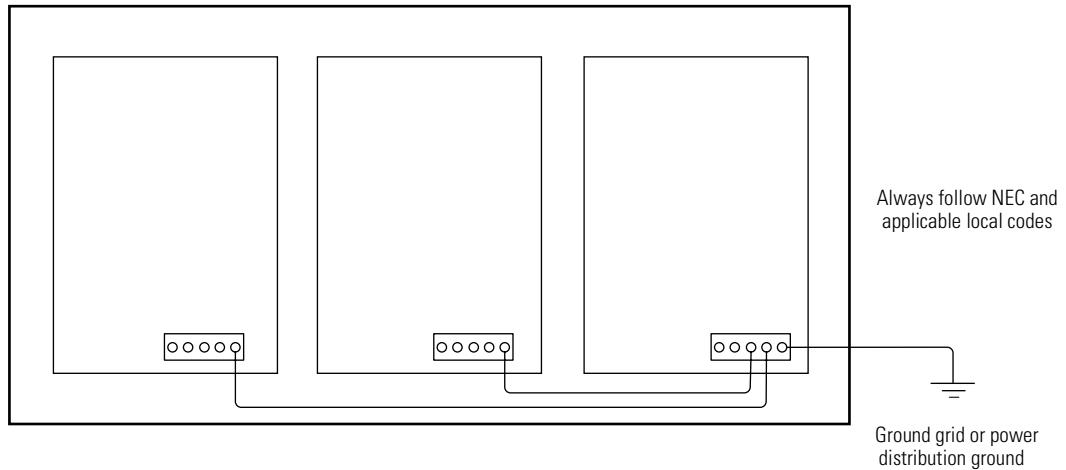

Motor Power Cable Shield Termination

Factory supplied motor power cables for MP-Series, 1326AB, and F-, H-, N-, and Y-Series motors are shielded, and the power cable is designed to be terminated at the drive during installation. A small portion of the cable jacket is removed which exposes the shield braid. The exposed area must be clamped to the bottom of the drive chassis (refer to Figure 3.11) or the front of the drive chassis (refer to Figure 3.12) using the clamp provided.

ATTENTION



To avoid hazard of electrical shock, ensure shielded power cables are grounded at a minimum of one point for safety.

Connecting Cable Shields at the Drive

All motor power cable shields require attachment to the clamp as shown in the figures below.

Figure 3.11
Motor Power Cable Shield Connection (bottom of drive)

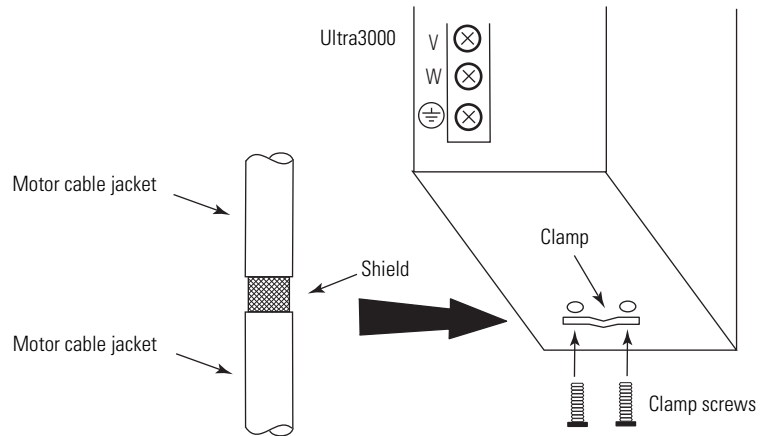
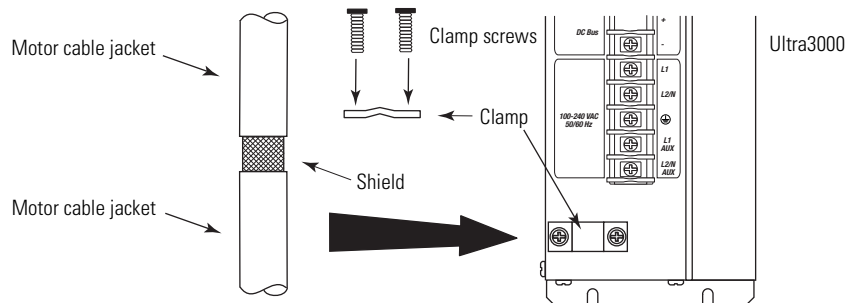

Figure 3.12
Motor Power Cable Shield Connection (front of drive)



IMPORTANT

The MP-Series Food Grade motors have shielded brake wires included in the motor power cable (2090-XXNPMF-xxSxx). Fold the brake wire shields back under the drive clamp before making connections to the brake circuit.

Connecting the Y-Series Cable Shield at the Motor

Y-Series motors have a short pigtail cable which connects to the motor, but is not shielded. The preferred method for grounding the Y-Series motor power cable on the motor side is to expose a section of the cable shield and clamp it directly to the machine frame. The motor power cable also has a 150 mm (6.0 in.) shield termination wire with a ring lug that connects to the closest earth ground. Use this method in addition to the cable clamp. The termination wire may be extended to the full length of the motor pigtail if necessary, but it is best to connect the supplied wire directly to ground without lengthening. Refer to Figure 3.13 for an illustration and Figure B.15 in *Appendix B* for the interconnect diagram.

Figure 3.13
Y-Series Motor Power Cable Connection

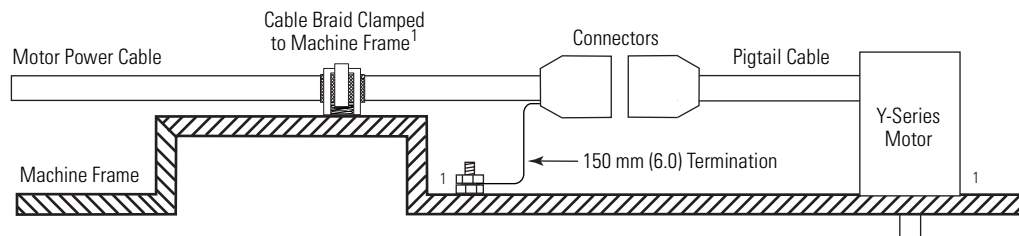

¹ Remove paint from machine frame to ensure proper HF-bond between machine frame and motor case, shield clamp, ground stud, etc.

Power Wiring Requirements

Power wiring requirements are given in the tables below. Wire should be copper with 75° C (167° F) minimum rating, unless otherwise noted. Phasing of main AC power is arbitrary and earth ground connection is required for safe and proper operation.

IMPORTANT

The National Electrical Code and local electrical codes take precedence over the values and methods provided.

Ultra3000 Power Wiring Requirements

Ultra3000 Drives	Description	Connects to Terminals TB1	Recommended Wire Size mm ² (AWG)	Terminal Block Torque Values Nm (lb-in.)
2098-DSD-005x-xx	Input Power ¹ 100-240V ac single-phase	L1, L2/N, and ⊕	1.5 (16)	1.25 (11)
2098-DSD-010x-xx			2.5 (14)	
2098-DSD-020x-xx			3 (12)	
2098-DSD-030x-xx	Input Power ¹ 100-240V ac single-phase	L1, L2/N, ⊕ L1 AUX, and L2/N AUX	6 (10)	4.0 (35)
2098-DSD-075x-xx	Input Power ¹ 100-240V ac three-phase	L1, L2, L3, ⊕ L1 AUX, and L2/N AUX	10 (8)	
2098-DSD-150x-xx				
2098-DSD-HV030x-xx	Input Power ¹ 230-480V ac three-phase	⊕ L3, L2, L1 L1 AUX, and L2/N AUX	2.5 (14)	1.25 (11)
2098-DSD-HV050x-xx			4 (12)	
2098-DSD-HV100x-xx			6 (10)	
2098-DSD-HV150x-xx			10 (8)	
2098-DSD-HV220x-xx				
All Ultra3000 drives (230V and 460V)	Motor Power	U, V, W, and ⊕	Motor power cable depends on motor/ drive combination.	

¹ The input power may be optionally isolated through a transformer.

Note: Refer to Figure 3.14 for TB1 terminal positions.

Figure 3.14
TB1 Terminal Positions

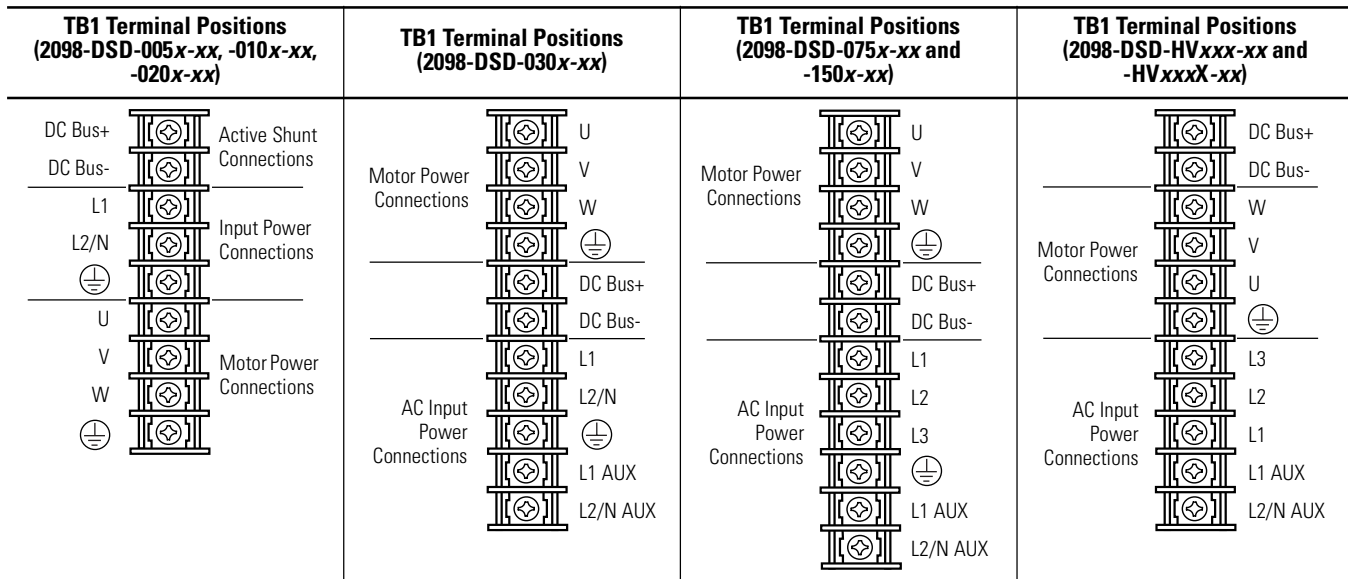

Shunt Module Power Wiring Requirements

Ultra3000 Drives	Shunt Module Catalog Number	Connects to Terminals	Recommended Wire Size mm ² (AWG)	Terminal Block Torque Values Nm (lb-in.)
2098-DSD-005x-xx, -010x-xx, and -020x-xx	2090-UCSR-A300	TB1-DC Bus+ TB1-DC Bus- TB1-L1 TB1-L2/N ⊕	4.0 (12) ¹	1.25 (11)
2098-DSD-030x-xx	9101-1183	TB2-1 TB2-2 TB2-3	2.5 (14) ¹	
2098-DSD-075x-xx and 2098-DSD-150x-xx	2090-UCSR-P900		10 (8) ¹	
2098-DSD-HV030-xx, -HV030X-xx -DSD-HV050-xx, and -HV050X-xx	2090-SR120-09		6 (10) ²	
2098-DSD-HV100-xx and -HV100X-xx	2090-SR040-09 or 2090-SR040-18			
2098-DSD-HV150-xx and -HV150X-xx	2090-SR025-09 or 2090-SR025-18			
2098-DSD-HV220-xx and -HV220X-xx	2090-SR020-36			

¹ 75° C (167° F), 600V copper wire. Maximum length 3.05 m (10 ft).

² 105° C (221° F), 600V copper wire (preferred) 90° C (194° F) (minimum). Maximum length 3.05 m (10 ft).

Note: Refer to Figure 3.15 for TB2 terminal positions.

Figure 3.15
TB2 Terminal Positions

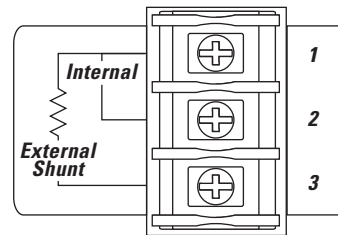

Refer to *Shunt Module Interconnect Diagrams* in *Appendix B* for an example with your Ultra3000 drive.

The Ultra3000 utilizes solid state motor overload protection which operates in accordance with UL 508C.

Motor overload protection trips:	At:
Eventually	100% overload.
Within 8 minutes	200% overload.
Within 20 seconds	600% overload.

IMPORTANT

Do not connect an external I/O power supply to the DC bus. The DC+ and DC- terminals connect directly to the power bus of the drive.

ATTENTION



This drive contains ESD (Electrostatic Discharge) sensitive parts and assemblies. You are required to follow static control precautions when you install, test, service, or repair this assembly. If you do not follow ESD control procedures, components can be damaged. If you are not familiar with static control procedures, refer to Allen-Bradley publication 8000-4.5.2, *Guarding Against Electrostatic Damage* or any other applicable ESD Protection Handbook.

ATTENTION

To avoid personal injury and/or equipment damage, ensure installation complies with specifications regarding wire types, conductor sizes, branch circuit protection, and disconnect devices. The National Electrical Code (NEC) and local codes outline provisions for safely installing electrical equipment.

To avoid personal injury and/or equipment damage, ensure motor power connectors are used for connection purposes only. Do not use them to turn the unit on and off.

To avoid personal injury and/or equipment damage, ensure shielded power cables are grounded to prevent potentially high voltages on the shield.

Connecting Input Power

This procedure assumes you have mounted your Ultra3000 drive and are ready to wire your AC input power.

IMPORTANT

When tightening screws to secure the wires, refer to the table on page 3-13 for torque values.

IMPORTANT

To ensure system performance, run wires and cables in the wireways as established in *Chapter 1*.

Refer to *Appendix B* for the power wiring diagram for your Ultra3000.

To wire your input power:

1. Prepare your wires by stripping approximately 12 mm (0.50 in.) of insulation from the end.

IMPORTANT

Use caution not to nick, cut, or otherwise damage strands as you remove the insulation.

2. Route the power cable to your Ultra3000 drive.

3. Locate the TB1 terminal block and remove the plastic cover. Refer to *Understanding Ultra3000 Connectors* in *Chapter 2* for the front panel connections of your Ultra3000 drive.

IMPORTANT

The auxiliary AC power inputs require dual element time delay (slow acting) fuses to accommodate inrush current. Refer to the section *Ultra3000 (230V) Power Specifications* in *Appendix A* for the inrush current on the auxiliary AC power input.

4. Using a screw driver, loosen the screw for each of the terminal locations and attach wires as shown in the table below.

If you have this drive:	Insert this wire from the power supply:	Into this terminal on TB1:
2098-DSD-005x-xx, -010x-xx, or -020x-xx	L1	L1
	L2	L2/N
	Ground	⊖
2098-DSD-030x-xx	L1	L1
	L2	L2/N
	Ground	⊖
	L1 (auxiliary AC)	L1 AUX
	L2 (auxiliary AC)	L2/N AUX
2098-DSD-075x-xx, -150x-xx or 2098-DSD-HVxxx-xx, -HVxxxX-xx	L1	L1
	L2	L2
	L3	L3
	Ground	⊖
	L1 (auxiliary AC)	L1 AUX
	L2 (auxiliary AC)	L2/N AUX

IMPORTANT

The DC bus connections should not be used for connecting multiple drives together. Contact your Allen-Bradley representative for further assistance if the application may require DC power connections.

5. Tighten each terminal screw. Refer to the table on page 3-13 for torque value.
6. Gently pull on each wire to make sure it does not come out of its terminal. Re-insert and tighten any loose wires.
7. Re-attach the plastic cover to the terminal block.

Connecting Motor Power and Brakes

This procedure assumes you have wired your input power and are ready to wire the motor power and brake connections.

IMPORTANT

When tightening screws to secure the wires, refer to the table on page 3-13 for torque values.

IMPORTANT

To ensure system performance, run wires and cables in the wireways as established in *Chapter 1*.

Refer to *Appendix B* for the power wiring diagram for your Ultra3000.

Applying the Motor Cable Shield Clamp

To apply the motor power cable shield clamp:

1. Loosen the two screws securing the cable clamp on the Ultra3000 drive (refer to figures 3.11 or 3.12 for the cable clamp location on your Ultra3000 drive).
2. Feed the cable into the clamp and position the exposed portion of the cable braid directly in line with the clamp.
3. Extend the cable along side the drive leaving an appropriate length of cable for terminating the motor power wires.
4. Check that the exposed cable braid is still in line with the clamp (adjust alignment if necessary).
5. Tighten the screws with a torque of 0.9-1.1 Nm (8.0-10.0 lb-in.).

Wiring Motor Power

When using MP-Series (low inertia and integrated gear), 1326AB, and F-, H-, or N-Series motors refer to Figure 3.16 for your motor power cable configuration. Refer to *Appendix B* for the motor/drive interconnect diagrams.

Figure 3.16
Motor Power Cable (MPL-A/B, MPG-A/B, 1326AB, and F-, H-, or N-Series Motors)

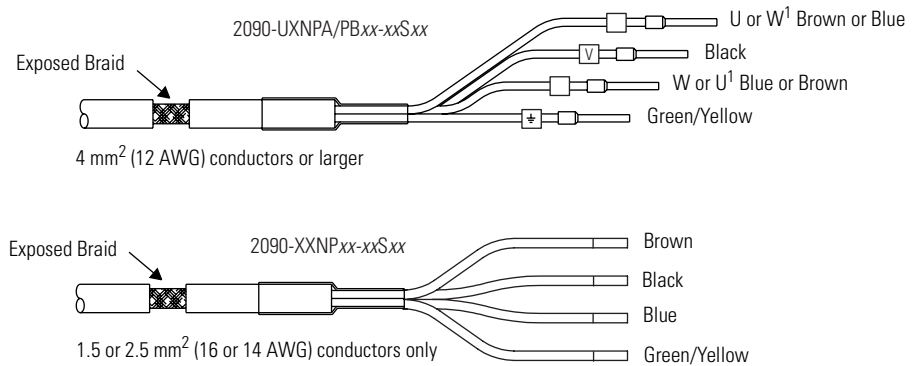

¹ Motor cable leads (shortest to longest) are labeled differently, depending on the drive input voltage (230V/460V).

When using MP-Series (food grade) motors, the brake wires are included in the motor power cable (2090-XXNPMF-xxSxx), as shown in Figure 3.17. Refer to *Appendix B* for the motor/drive interconnect diagram.

Figure 3.17
Motor Power Cable (MPF-A/B Food Grade Motors)

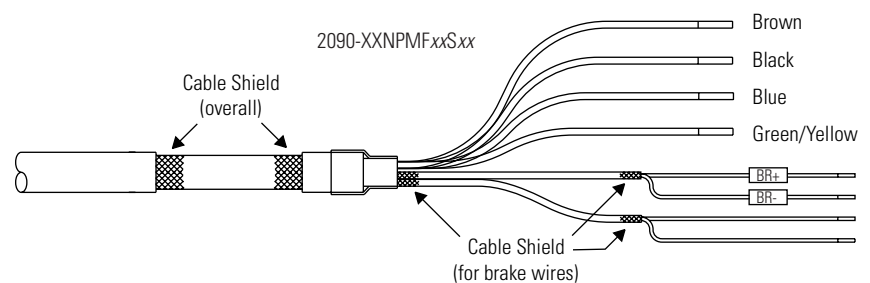

When using Y-Series motors, the brake wires are included in the motor power cable (2090-XXNPY-16Sxx), as shown in Figure 3.18. Refer to *Appendix B* for the motor/drive interconnect diagram.

Figure 3.18
Motor Power Cable (Y-Series Motors)

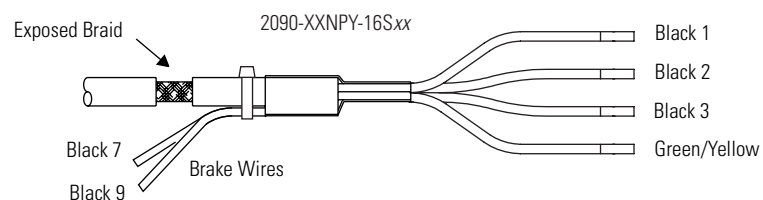

Refer to the table below for the catalog number of the motor power cable for your Ultra3000 drive.

For this motor:	This Universal Cable is available:	Use this Motor Power Cable when Universal Cables are not available:
MP-Series (Low Inertia and Integrated Gear) (230V or 460V systems)	2090-XXNPMP-16Sxx 2090-XXNPMP-14Sxx 2090-XXNPMP-10Sxx 2090-XXNPMP-8Sxx	N/A
1326AB-Series (M2L/S2L)		
MP-Series (Food Grade)	2090-XXNPMF-16Sxx 2090-XXNPMF-14Sxx 2090-XXNPMF-10Sxx	
F-Series	2090-XXNPHF-16Sxx 2090-XXNPHF-14Sxx	2090-UXNPAHF-10Sxx 2090-UXNPAHF-8Sxx
H-Series	2090-XXNPH-16Sxx 2090-XXNPHF-14Sxx	2090-UXNPAHF-10Sxx 2090-UXNPAHF-8Sxx 2090-UXNPAH-6Sxx
N-Series	2090-XXNPN-16Sxx	N/A
Y-Series	2090-XXNPY-16Sxx	N/A



To wire your motor power:

1. Route the motor power cable to your Ultra3000 drive.

IMPORTANT

To ensure system performance, run wires and cables in the wireways as established in *Chapter 1*.

2. Using a screw driver, loosen the screw for each of the terminal locations and attach wires as shown in the table below.

Insert the motor power wires from this servo motor:		Into this terminal on TB1:
1326AB- (M2L/S2L), F-, H-, N-, and MP-Series	Y-Series	
U / Brown	1 / Black	U
V / Black	2 / Black	V
W / Blue	3 / Black	W
 Green/Yellow	 Green/Yellow	

IMPORTANT

Ensure motor power is wired with proper phasing relative to the motor terminals. On some motors, the motor leads may be labeled R, S, and T which correspond to U, V, and W respectively.

3. Tighten each terminal screw. Refer to the table on page 3-13 for torque values.

4. Gently pull on each wire to make sure it does not come out of its terminal. Re-insert and tighten any loose wires.
- 5.

If your motor is:	Then:
Y-Series	<ol style="list-style-type: none"> 1. Connect the 152.4 mm (6.0 in.) termination wire at the motor end of the cable to the closest earth ground (refer to Figure 3.13 for an illustration). 2. Go to <i>Understanding Motor Brake Connections</i>.
Not Y-Series	Go to <i>Understanding Motor Brake Connections</i> .

Understanding Motor Brake Connections

The procedure for wiring your motor brake varies slightly, depending on the motor series you are using. Refer to the table below to determine where the brake wires for your servo motor are located and for the appropriate brake cable or connector kit catalog number.

For this Motor Series:	The Brake Wires are:	Cable Catalog Number:
MP-Series (low inertia and integrated gear)	In a separate brake cable (the motor has a brake connector)	2090-UXNBMP-18Sxx brake cable
1326AB-Series (M2L/S2L)		Cable connector kit 9101-0330
F-Series		
H-Series		
N-Series		Cable connector kit 9101-1698
MP-Series (food grade)	Included in the power cable (the motor does not have a brake connector)	2090-XXNPMF-xxSxx power cable
Y-Series		2090-XXNPY-16Sxx power cable

To wire your motor brakes refer to *Ultra3000/Motor Interconnect Diagrams* in *Appendix B* for the interconnect diagram showing the brake connections for your Ultra3000 drive and servo motor.

Understanding Shunt Connections

Follow these guidelines when installing and wiring your active or passive shunt module/resistor.

IMPORTANT When tightening screws to secure the wires, refer to the table on page 3-13 for torque values.

IMPORTANT To ensure system performance, run wires and cables in the wireways as established in *Chapter 1*.

Refer to *Appendix B* for the Ultra3000 interconnect diagrams.

If your application requires an:	And you are wiring to this Ultra3000 drive:	Then refer to:
External Shunt	2098-DSD-005x-xx, 2098-DSD-010x-xx, or 2098-DSD-020x-xx	<ul style="list-style-type: none"> • <i>Planning Your Panel Layout</i> in <i>Chapter 1</i>. • Figure B.5 on page B-7 of <i>Appendix B</i>. • The installation instructions provided with your shunt (publication 2090-IN002x-EN-P).
	2098-DSD-030x-xx	<ul style="list-style-type: none"> • <i>Planning Your Panel Layout</i> in <i>Chapter 1</i>. • Figure B.7 on page B-8 of <i>Appendix B</i>. • The installation instructions provided with your shunt (publication 2090-IN003x-EN-P).
	2098-DSD-075x-xx, or 2098-DSD-150x-xx	<ul style="list-style-type: none"> • <i>Planning Your Panel Layout</i> in <i>Chapter 1</i>. • Figures B.7 and B.8 on page B-8 of <i>Appendix B</i>. • The installation instructions provided with your shunt (publication 2090-IN001x-EN-P).
	2098-DSD-HV030-xx, -HV050-xx, or -HV100-xx	<ul style="list-style-type: none"> • <i>Planning Your Panel Layout</i> in <i>Chapter 1</i>. • Figure B.7 on page B-8 of <i>Appendix B</i>. • The installation instructions provided with your shunt (publication 2090-IN004x-EN-P).
	2098-DSD-HV150-xx, or -HV220-xx	<ul style="list-style-type: none"> • <i>Planning Your Panel Layout</i> in <i>Chapter 1</i>. • Figure B.9 on page B-9 of <i>Appendix B</i>. • The installation instructions provided with your shunt.
Internal Shunt	2098-DSD-030x-xx, 2098-DSD-075x-xx, 2098-DSD-150x-xx, 2098-DSD-HVxxx-xx, or 2098-DSD-HVxxxX-xx	Verify the TB2 internal shunt jumper is in place between TB2-1 and TB2-2, as shown in Figure 3.19 below.

Figure 3.19
Connecting Your Shunt Resistor

Connecting the Internal Shunt Resistor¹

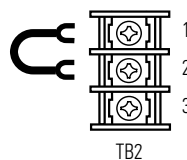

¹ This is the factory default jumper setting for TB2.

Understanding Feedback and I/O Cable Connections

Factory made cables with premolded connectors are designed to minimize EMI and are recommended over hand-built cables to improve system performance. However, other options are available for building your own feedback and I/O cables. Refer to the table below for the available options.

Drive Connector	Connector Option	Option Catalog Number	Reference	
CN1 I/O Connector	44-pin drive-mounted breakout board with 24V to 5V auxiliary power converter	2090-U3CBB-DM44	<ul style="list-style-type: none"> • <i>CN1 Control Interface Breakout Boards with 24V to 5V Auxiliary Power Converter</i> (publication 2090-IN008x-EN-P). • <i>Understanding Ultra3000 I/O Specifications</i> beginning on page 2-26. 	
	12-pin drive-mounted breakout board with 24V to 5V auxiliary power converter for SERCOS interface applications	2090-U3CBB-DM12		
	44-pin panel-mounted breakout board kit	2090-U3BK-D44xx	<i>Understanding Ultra3000 I/O Specifications</i> beginning on page 2-26.	
	44-pin, drive-mounted breakout board. ¹	2090-U3BB2-DM44		
	44-pin (high-density D-shell) drive connector kit	2090-U3CK-D44		
		Single-axis flying lead to 1756-M02AE module or 1784-PM02AE PCI card	2090-U3CC-D44xx	<ul style="list-style-type: none"> • <i>Understanding Ultra3000 I/O Specifications</i> on page B-20. • <i>Understanding Ultra3000 I/O Specifications</i> beginning on page 2-26.
		Two-axis pre-wired to 1756-M02AE module	2090-U3AE-D44xx	
CN2 Feedback Connector	Premolded cable at drive and motor end	2090-UXNFBxx-Sxx	<ul style="list-style-type: none"> • The table below for your motor feedback cable catalog number. • <i>Motor Feedback Connector Pin-outs</i> on page 3-24. • <i>Understanding Motor Encoder Feedback Specifications</i> beginning on page 2-40. 	
	Flying lead cable at drive end (2090-XXNFxx-Sxx)	15-pin drive-mounted breakout board		2090-UXBB-DM15
		15-pin panel-mounted breakout board kit		2090-UXBK-DM15xx
		15-pin (high-density D-shell) drive connector kit		2090-UXCK-D15
CN3 Serial Connector	PC serial connector to premolded drive connector	2090-UXPC-DM09	<i>Understanding the Serial Interface</i> beginning on page 2-51.	
	9-pin drive-mounted breakout board	2090-UXBB-DM09		
	9-pin (high-density D-shell) drive connector kit	2090-UXCK-D09		

¹ This breakout board accepts 1 - 0.14 mm² (16 - 26 AWG) wire. For applications that require a 44-pin drive-mounted breakout board that accepts 4 - 0.5 mm² (12 - 22 AWG) wire, contact your local Allen-Bradley representative.

Refer to the table below for motor feedback cable catalog numbers available for specific motor/feedback combinations.

For this Motor Series:	Using this Type of Motor Feedback:	Use this Feedback Cable	
		Premolded:	Flying Lead:
MPL-Axxxx or MPG-Axxx-xxx	High-resolution encoder	2090-UXNFBMP-Sxx	2090-XXNFMP-Sxx ¹
MPL-Axxxx	Incremental encoder		
MPL-Bxxxx or MPG-Bxxx-xxx	High-resolution encoder		
1326AB	M2L/S2L High-resolution encoder		
MPF-Axxxx or MPF-Bxxxx	High-resolution encoder	N/A	2090-XXNFMF-Sxx ¹
F-Series	Incremental encoder	2090-UXNFBHF-Sxx	2090-XXNFHF-Sxx ¹
H-Series		2090-UXNFBN-Sxx	2090-XXNFN-Sxx ¹
N-Series			
Y-Series		2090-UXNFBY-Sxx	2090-XXNFY-Sxx ¹

¹ Requires 2090-UXBB-DM15 drive-mounted breakout board, 2090-UXBK-D15xx breakout board kit, or 2090-UXCK-D15 mating connector kit.

Note: Refer to *Maximum Feedback Cable Lengths* on page A-13 to determine the maximum length of your motor feedback cable.

Motor Feedback Connector Pin-outs

The following tables provide the signal descriptions and pin-outs for the motor feedback (CN2) 15-pin connector to MP-Series (low inertia and integrated gear), 1326AB, and N-Series motors.

Motor Connector Pin	High Resolution Feedback Signals for:		Incremental Encoder Feedback Signals for:	Drive (CN2) Connector Pin
	MPL-Bxxx-M/-S MPL-A5xx-M/-S and 1326AB-Bxxx-M2L/-S2L Motors	MPL-A3xx-M/-S MPL-A4xx-M/-S MPL-A45xx-M/-S MPG-A/Bxxx-M/-S Motors	MPL-Axxx-H MPL-Bxxx-H and N-Series Motors	
A	Sine+	Sine+	AM+	1
B	Sine-	Sine-	AM-	2
C	Cos+	Cos+	BM+	3
D	Cos-	Cos-	BM-	4
E	Data+	Data+	IM+	5
F	Data-	Data-	IM-	10
K	Reserved	EPWR_5V	EPWR_5V	14
L	Reserved	ECOM	ECOM	6
N	EPWR_9V	Reserved	Reserved	7
P	ECOM	Reserved	Reserved	6
R	TS+	TS+	TS+	11
S	TS-	TS-	TS-	6
T	Reserved	Reserved	S1/Hall A	12
U	Reserved	Reserved	S2/Hall B	13
V	Reserved	Reserved	S3/Hall C	8

The following tables provide the signal descriptions and pin-outs for the motor feedback (CN2) 15-pin connector to MP-Series food grade motors.

Motor Connector Pin	High Resolution Feedback Signals for:		Drive (CN2) Connector Pin
	MPF-Bxxx-M/-S and MPF-A5xx-M/-S Motors	MPF-A3xx-M/-S MPF-A4xx-M/-S MPF-A45xx-M/-S Motors	
1	Sine+	Sine+	1
2	Sine-	Sine-	2
3	Cos+	Cos+	3
4	Cos-	Cos-	4
5	Data+	Data+	5
6	Data-	Data-	10
9	Reserved	EPWR_5V	14
10	Reserved	ECOM	6
11	EPWR_9V	Reserved	7
12	ECOM	Reserved	6
13	TS+	TS+	11
14	TS-	TS-	6

The following tables provide the signal descriptions and pin-outs for the motor feedback (CN2) 15-pin connector to F-, H-, and Y-Series (230V) motors.

Motor Connector Pin	Incremental Encoder Feedback Signals to F- and H-Series Motors	Drive Connector Pin
A	AM+	1
B	AM-	2
C	BM+	3
D	BM-	4
E	IM+	5
F	IM-	10
G	Reserved	–
H	Reserved	–
J	EPWR_5V	14
K	EPWR_5V	14
L	ECOM	6
M	ECOM	6
N	S2/Hall B	13
P	S3/Hall C	8
R	TS+	11
S	TS-	6
T	S1/Hall A	12

Motor Connector Pin	Incremental Encoder Feedback Signals to Y-Series Motors	Drive (CN2) Connector Pin
9	AM+	1
10	AM-	2
11	BM+	3
12	BM-	4
13	IM+	5
14	IM-	10
15	S1/Hall A	12
17	S2/Hall B	13
19	S3/Hall C	8
22	EPWR_5V	14
23	ECOM	6
24	Drain	Connector Housing
Reserved	Reserved	7
Reserved	Reserved	9
Reserved	Reserved	11
Reserved	Reserved	15

Connecting Your SERCOS Fiber-Optic Cables

This procedure assumes you have your ControlLogix chassis with 1756-MxxSE interface module or personal computer with 1784-PM16SE PCI card and Ultra3000 SERCOS interface system(s) mounted and are ready to connect the fiber-optic cables.

The SERCOS fiber-optic ring is connected using the SERCOS Receive and Transmit connectors. Refer to *Chapter 2* for the location of the connectors on your Ultra3000-SE drive(s) and Figure 3.20 to locate the connectors on your SERCOS interface module or PCI card.

Note: Plastic cable is available in lengths up to 32 m (105.0 ft). Glass cable is available in lengths up to 200 m (656.7 ft).

Figure 3.20
ControlLogix and SoftLogix SERCOS Connector Locations

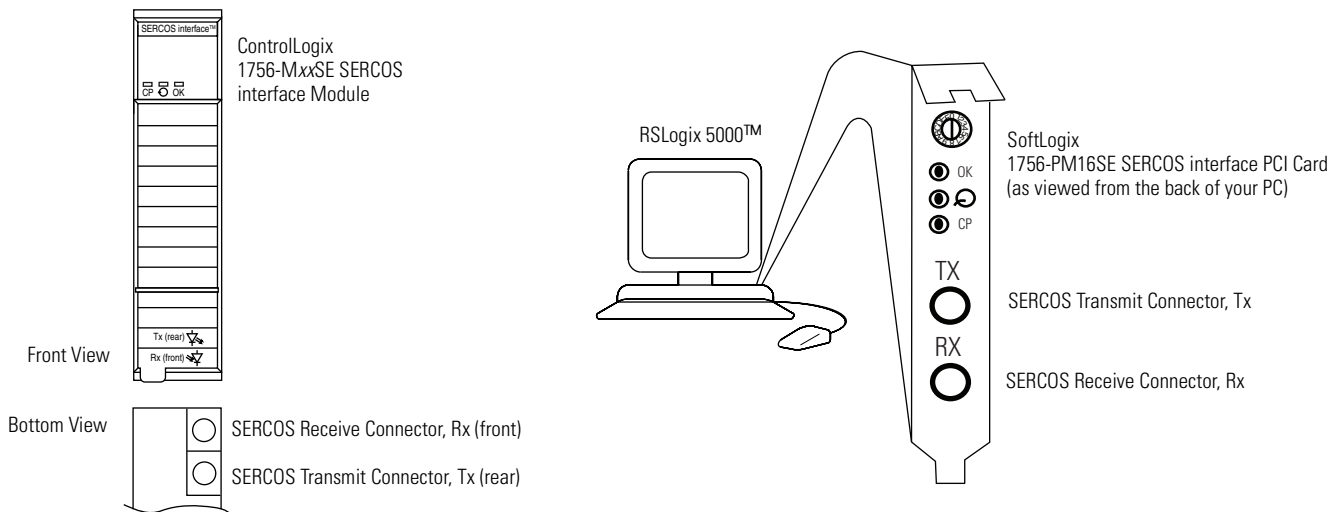

Refer to Figure 3.21 for an example of fiber-optic ring connections between the Ultra3000-SE drive(s) and the SoftLogix PCI card.

Figure 3.21
Fiber-Optic Ring Connection (Example 1)

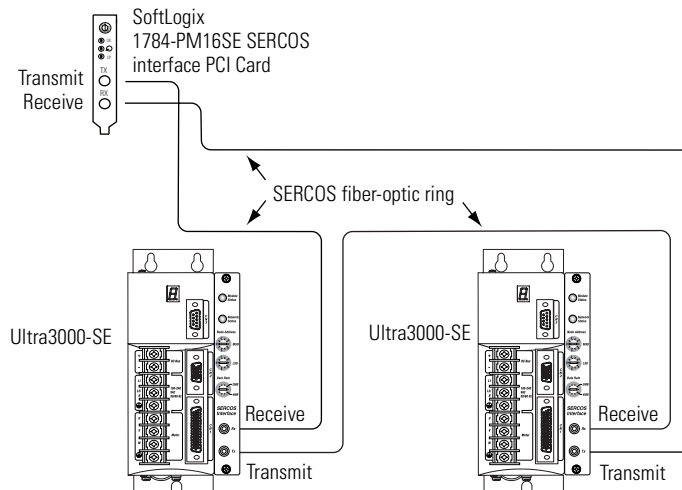

Refer to figures 3.22, 3.23, and 3.24 for examples of fiber-optic ring connections between the Ultra3000-SE drive(s) and the ControlLogix SERCOS interface module.

Figure 3.22
Fiber-Optic Ring Connection (Example 2)

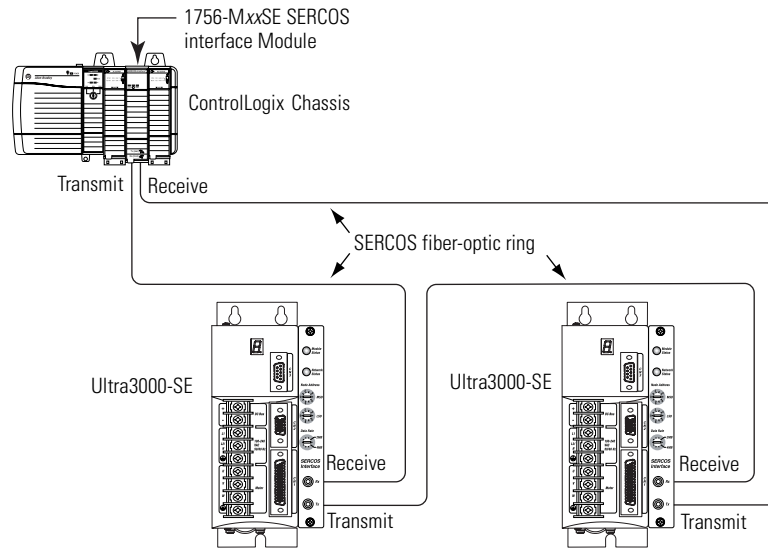
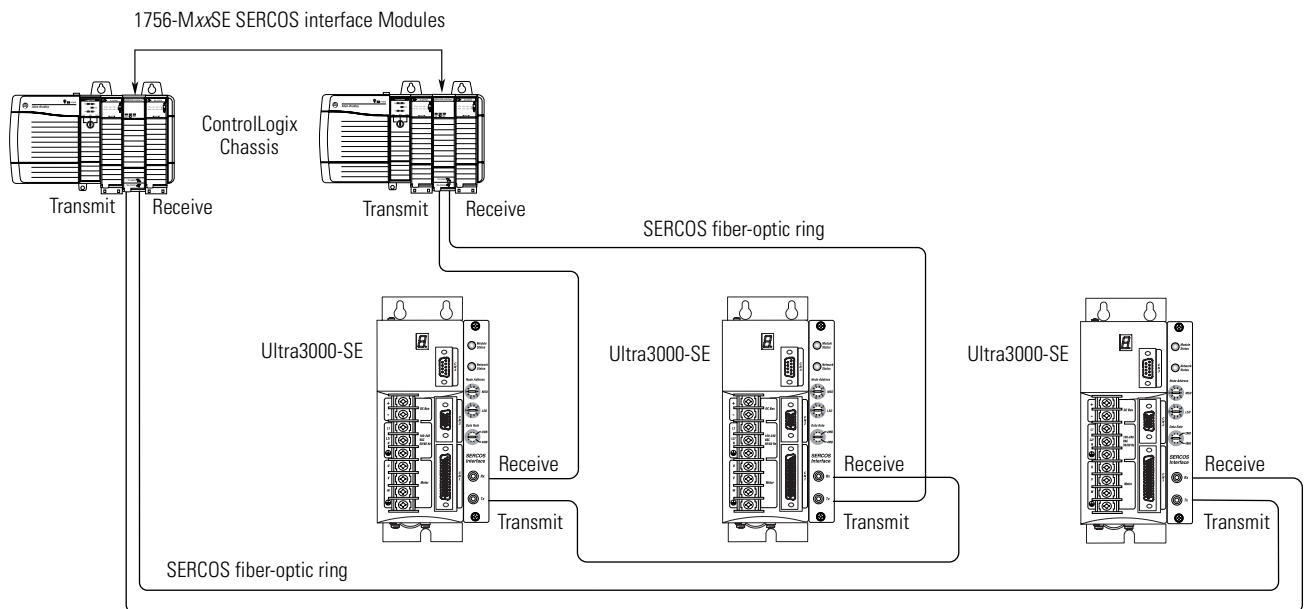

Figure 3.23
Fiber-Optic Ring Connection (Example 3)



Note: You can mount the two 1756-MxxSE SERCOS interface modules in two separate ControlLogix chassis (as shown above) or you can mount them in the same chassis.

Cable lengths of 32 m (105 ft) for plastic cable and 200 m (656.7 ft) for glass cable are possible for each transmission section (point A to B). In Figure 3.24, the second Ultra3000-SE system is located in a separate cabinet and connected with bulkhead adapters.

IMPORTANT

To avoid signal loss, do not mix glass and plastic cables when connecting to a bulkhead adapter. Use glass-to-glass or plastic-to-plastic cable on both sides of the adapter.

IMPORTANT

Clean the fiber-optic cable connectors prior to installation. Dust in the connectors can reduce signal strength. For more information, refer to *Fiber Optic Cable Installation and Handling Instructions* (publication 2090-IN010x-EN-P).

Figure 3.24
Fiber-Optic Ring Connection (Example 4)

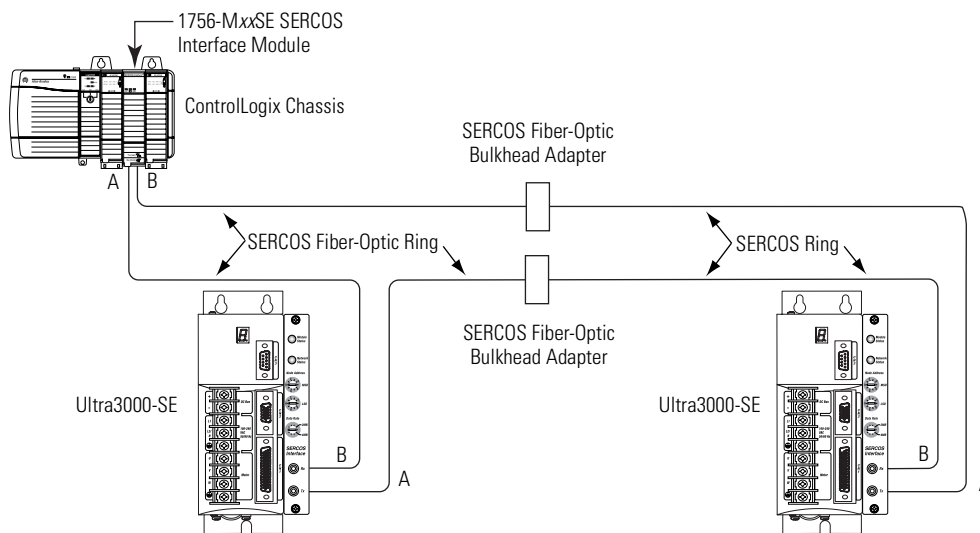

To connect the SERCOS fiber-optic cables:

1. Insert one end of a fiber-optic cable into the Receive SERCOS connector on the Ultra3000-SE and thread the connector on finger tight.
2. Insert the other end of the cable (from step 1) into the Transmit SERCOS connector on the ControlLogix module/SoftLogix PCI Card and thread the connector on finger tight.
3. Insert one end of another fiber-optic cable into the Transmit SERCOS connector on the last Ultra3000-SE drive in the ring and thread the connector on finger tight.

4. Insert the other end of the cable (from step 3) into the Receive SERCOS connector on the ControlLogix module/SoftLogix PCI Card and thread the connector on finger tight.
5. Complete the ring by connecting the Transmit and Receive connectors from one drive to the next until all are connected (refer to the examples above).

Refer to *Appendix C* for SERCOS fiber-optic cable and bulkhead adapter catalog numbers.

Connecting to a DeviceNet Network

A DeviceNet network is an arrangement of electrical power and device distribution. A DeviceNet network is planned and adjusted for optimal communications.

Before proceeding to add devices, you need to record the following:

- Network data rate
- Network cable system map (topology) to which you are connecting
- Distances between cable system components
- Device current draw and voltage drop for each device on the network
- Limitation of the trunk and drop cables

Refer to the table below for recommended trunk and drop lengths.

Data Rates	125 Kbps	250 Kbps	500 Kbps
Thick Trunk Line	500 m (1,640 ft)	250 m (820 ft)	100 m (328 ft)
Thin Trunk Lengths	100 m (328 ft)	100 m (328 ft)	100 m (328 ft)
Maximum Drop Length	6 m (20 ft)	6 m (20 ft)	6 m (20 ft)
Cumulative Drop Budget	156 m (512 ft)	78 m (256 ft)	39 m (128 ft)

Refer to the *DeviceNet Cable System Planning and Installation Manual* (publication DN-6.7.2) for specific guidance in calculating and attaching the Ultra3000-DN to a network.

Connecting Your DeviceNet Cable

To wire the DeviceNet connector:

1. Strip 65 mm (2.6 in.) to 75 mm (2.96 in.) of the outer jacket from the end of the cable, leaving no more than 6.4 mm (0.25 in.) of the braided shield exposed.

Figure 3.25
Exposing the Braided Shield

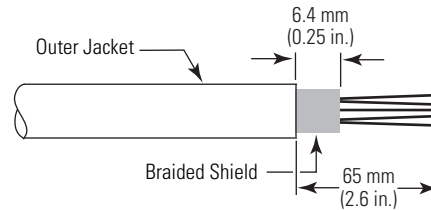

2. Wrap the end of the cable with 38 mm (1.5 in.) of shrink wrap, covering part of the exposed wires and part of the outer jacket.

Figure 3.26
Adding Shrink Wrap

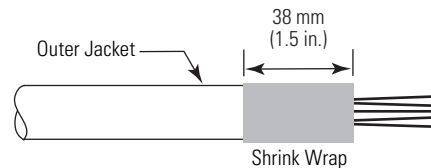

3. Strip 8.1 mm (0.32 in.) of the insulation from the end of each of the insulated wire.

IMPORTANT

Use caution not to nick, cut, or otherwise damage strands as you remove the insulation.

Trim the last 6.4 mm (0.25 in.) of the bare wires so that the outside dimension does not exceed 0.17 mm (0.045 in.).

Figure 3.27
Exposing Wire Strands

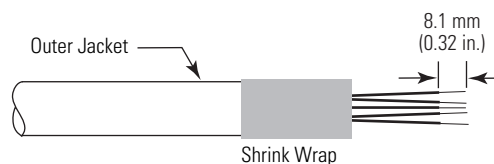

- Using a screwdriver, loosen the screw for each of the terminal locations (refer to Figure 3.28) and attach wires as shown in the table below.

Insert this wire:		Into this terminal on the DeviceNet connector:
Color	Designation	
Black	V-	1
Blue	Can_L	2
Bare	Shield	3
White	Can_H	4
Red	V+	5

Figure 3.28
Wiring the DeviceNet Connector

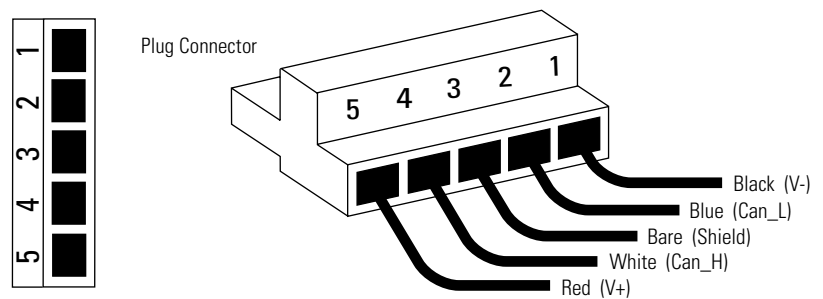

- Tighten each terminal screw using a 1/8 inch flat blade screwdriver.
- Gently pull on each wire to make sure it does not come out of its terminal. Re-insert and tighten any loose wires.
- Plug the DeviceNet cable into the DeviceNet interface connector. Refer to *Ultra3000 (with DeviceNet) Front Panel Connections* beginning on page 2-18 for the connector location.
- Attach the Ultra3000 with DeviceNet to the DeviceNet network.

Troubleshooting Status Indicators

Chapter Objectives

This chapter provides a description of maintenance and troubleshooting activities for the Ultra3000. This chapter includes these sections:

- Safety Precautions
- General Troubleshooting
- Troubleshooting for SERCOS Drives
- Troubleshooting for DeviceNet Drives

For power-up procedures and system integration with Ultraware or ControlLogix and SoftLogix modules/PCI cards (see table below) refer to the *Ultra3000 Digital Servo Drives Integration Manual* (publication 2098-IN005x-EN-P). Manuals are available electronically (as a .pdf) or in hardcopy from www.theautomationbookstore.com.

Interface	ControlLogix Motion Module	SoftLogix PCI Card
SERCOS interface	1756-MxxSE	1784-PM16SE
Analog interface	1756-M02AE	1784-PM02AE

Safety Precautions

Observe the following safety precautions when troubleshooting your Ultra3000 drive.

ATTENTION

DC bus capacitors may retain hazardous voltages after input power has been removed. Before working on the drive, measure the DC bus voltage to verify it has reached a safe level or wait the full time interval listed on the drive warning label. Failure to observe this precaution could result in severe bodily injury or loss of life.

Do not attempt to defeat or override the drive fault circuits. You must determine the cause of a fault and correct it before you attempt to operate the system. If you do not correct a drive or system malfunction, it could result in personal injury and/or damage to the equipment as a result of uncontrolled machine system operation.

Test equipment (such as an oscilloscope or chart recorder) must be properly grounded. Failure to include an earth ground connection could result in a potentially fatal voltage on the oscilloscope chassis.

General Troubleshooting

Refer to the *Error Codes* section below to identify problems, potential causes, and appropriate actions to resolve the problems. If problems persist after attempting to troubleshoot the system, please contact your Allen-Bradley representative for further assistance. To determine if your Ultra3000 drive has an error, refer to the table below.

If the Logic Power LED is ON and the Status LED display on your:	Is:	Then:
2098-DSD-xxx, -xxxX, -HVxxx, or -HVxxxX drive	Actively cycling segments in a full circle	Your Ultra3000 drive is ready.
2098-DSD-xxx-DN, -xxxX-DN, -HVxxx-DN, -HVxxxX-DN drive		Your Ultra3000 drive is ready.
2098-DSD-xxx-SE or -HVxxx-SE drive	Displaying a fixed 4	Your Ultra3000 drive is ready.
All drives	Flashing E followed by two numbers	Your Ultra3000 drive has an error. Proceed to the section <i>Error Codes</i> below.
	Flashing L	Your Ultra3000 drive is in an Overtravel condition and motion restrictions are in effect.

Error Codes

The following list of problematic symptoms (no error code shown) and problems with assigned error codes is designed to help you resolve problems.

When a fault is detected, the seven-segment LED will display an E followed by the flashing of the two-digit error code, one digit at a time. This is repeated until the problem is cleared.

Error Code	Problem or Symptom	Possible Cause(s)	Action/Solution
	Power (PWR) indicator not ON	No AC power or auxiliary logic power.	Verify AC power or auxiliary +5V logic power is applied to the Ultra3000.
		Internal power supply malfunction.	Call your Allen-Bradley representative.
	Power (PWR) indicator is ON, but seven segment Status LED display is OFF. Note: This applies to 2098-DSD-005, -010, and -020 Ultra3000 models only.	Externally applied +5V auxiliary power supply voltage is too low.	Verify that the external +5V auxiliary power supply (as measured at the drive terminals) reads between 5.10V and 5.25V.
	Motor jumps when first enabled	Motor wiring error.	Check motor wiring.
		Incorrect motor chosen.	Verify the proper motor is selected.
	Digital I/O not working correctly	I/O power supply disconnected.	Verify connections and I/O power source.
E01	Non-Volatile Memory Endurance Exceeded	Range of motion and number of home position definitions during the product life exceeds the maximum allowed (applies only to systems with absolute feedback).	This is an unrecoverable fault, the drive must be sent back to the factory.
E02	Velocity Exceeds Position Rollover /2	The velocity command or feedback exceeds half the machine cycle length per millisecond (applies only when the machine cycle position rollover is enabled).	Increase machine cycle size or reduce velocity profile. This error only applies to firmware versions prior to 1.10.

Error Code	Problem or Symptom	Possible Cause(s)	Action/Solution
E03	Absolute Feedback Range Exceeded	The motor position exceeds +/- 2047 revolutions from the home position (applies only to systems with absolute feedback).	<ul style="list-style-type: none"> Decrease application range of motion. Upgrade firmware.
E04	Motor Overtemperature	Motor thermostat trips due to: <ul style="list-style-type: none"> High motor ambient temperature and/or Excessive current 	<ul style="list-style-type: none"> Operate within (not above) the continuous torque rating for the ambient temperature (40°C maximum). Lower ambient temperature, increase motor cooling.
		Motor wiring error.	Check motor wiring.
		Incorrect motor selection.	Verify the proper motor has been selected.
E05	IPM Fault	Motor cables shorted.	Verify continuity of motor power cable and connector.
		Motor winding shorted internally.	Disconnect motor power cables from the motor. If the motor is difficult to turn by hand, it may need to be replaced.
		Ultra3000 temperature too high.	<ul style="list-style-type: none"> Check for clogged vents or defective fan. Ensure cooling is not restricted by insufficient space around the unit.
		Operation above continuous power rating.	<ul style="list-style-type: none"> Verify ambient temperature is not too high. Operate within the continuous power rating. Reduce acceleration rates.
		Ultra3000 has a bad IPM output, short circuit, or overcurrent.	Remove all power and motor connections, and preform a continuity check from the DC bus to the U, V, and W motor outputs. If a continuity exists, check for wire fibers between terminals, or send drive in for repair.
		An attempt was made to enable the drive without waiting at least 1.0 second after applying the main AC power. Note: This applies to 2098-DSD-005, -010, and -020 Ultra3000 models only (when using an external +5V auxiliary power supply).	Wait at least 1.0 second after the main AC is applied before enabling the drive.
E06	Hardware Overtravel (SERCOS only)	Dedicated overtravel input is inactive.	<ul style="list-style-type: none"> Check wiring. Verify motion profile.
E07	RESERVED		Call your local Allen-Bradley representative.
E08	RESERVED		
E09	Bus Undervoltage	Low AC line/AC power input.	<ul style="list-style-type: none"> Verify voltage level of the incoming AC power. Check AC power source for glitches or line drop. Install an uninterruptible power supply (UPS) on your AC input.

Error Code	Problem or Symptom	Possible Cause(s)	Action/Solution
E10	Bus Overvoltage	Excessive regeneration of power. When the motor is driven by an external mechanical power source, it may regenerate too much peak energy through the Ultra3000's power supply. The system faults to save itself from an overload.	<ul style="list-style-type: none"> • Change the deceleration or motion profile. • Use a larger system (motor and Ultra3000). • Use a resistive shunt. • If a shunt is connected, verify the wiring is correct and shunt fuse is not blown.
		Excessive AC input voltage.	Verify input is within specifications.
E11	IllegalHall State	Incorrect phasing.	Check the Hall phasing.
		Bad connections.	<ul style="list-style-type: none"> • Verify the Hall wiring. • Verify 5V power supply to the encoder.
E12	Home Search Failed	Home sensor and/or marker is outside the overtravel limits.	<ul style="list-style-type: none"> • Check wiring. • Reposition the overtravel limits or sensor.
E13	Home Position In Limit	Home sensor, marker, or final home position exceeds a hardware overtravel limit.	<ul style="list-style-type: none"> • Reposition the overtravel limits or home sensor. • Adjust the final home position.
E14	SERCOS Hardware Fault (SERCOS drives only)	A fault was detected with the operation of the drive's internal SERCOS hardware.	Contact your local Allen-Bradley representative.
	DeviceNet Communications Network problem (DeviceNet drives only)	DeviceNet communications network is broken	Troubleshoot DeviceNet communications.
E15	Excessive Electrical Cycle Length	Electrical cycle length exceeds maximum lines per electrical cycle	Replace the linear motor/encoder.
E16	Software Overtravel (SERCOS only)	Programmed overtravel limit has been exceeded.	<ul style="list-style-type: none"> • Verify motion profile. • Verify overtravel settings are appropriate.
E17	User-Specified Current Fault	User-Specified average current level has been exceeded.	Increase to a less restrictive setting.
E18	Overspeed Fault	Motor speed has exceeded 125% of maximum rated speed.	<ul style="list-style-type: none"> • Check cables for noise. • Check tuning.
E19	Excess Position Error	Position error limit was exceeded.	<ul style="list-style-type: none"> • Increase the feedforward gain. • Increase following error limit or time. • Check position loop tuning.

Error Code	Problem or Symptom	Possible Cause(s)	Action/Solution
E20	Motor Encoder State Error	The motor encoder encountered an illegal transition.	<ul style="list-style-type: none"> • Replace the motor/encoder. • Use shielded cables with twisted pair wires. • Route the feedback away from potential noise sources. • Check the system grounds. • Verify that the unbuffered encoder signals are not subjected to EMI in the CN1 cable. Remove these signals from the CN1 cable if they are not being used. • Verify that the motor has a high-frequency bond to the drive's enclosure panel. • Verify that any stage connected to the motor shaft (for example using a ball screw) has a high-frequency bond to the machine frame and the drive's enclosure panel.
		Bad encoder.	Replace motor/encoder.
E21	Auxiliary Encoder state error	The auxiliary encoder encountered an illegal transition.	<ul style="list-style-type: none"> • Use shielded cables with twisted pair wires. • Route the encoder cable away from potential noise sources. • Bad encoder - replace encoder. • Check the ground connections.
		Setup time violation for Step/Direction or CW/CCW input.	Check timing of Step/Direction or CW/CCW inputs to determine if setup time requirements are being met.
E22	Motor Thermal Protection Fault	The internal filter protecting the motor from overheating has tripped.	<ul style="list-style-type: none"> • Reduce acceleration rates. • Reduce duty cycle (ON/OFF) of commanded motion. • Increase time permitted for motion. • Use larger Ultra3000 and motor. • Check tuning.
E23	IPM Thermal Protection Fault	The internal filter protecting the drive from over heating has tripped.	<ul style="list-style-type: none"> • Reduce acceleration rates. • Reduce duty cycle (ON/OFF) of commanded motion. • Increase time permitted for motion. • Use larger Ultra3000 and motor. • Check tuning.
E24	Excess Velocity Error	Velocity error limit was exceeded.	<ul style="list-style-type: none"> • Increase time or size of allowable error. • Reduce acceleration. • Check tuning.
E25	Sensor Not Assigned	Homing or registration motion was attempted without a sensor assigned.	Assign a sensor to a digital input.
E26	User-Specified Velocity Fault	User specified velocity level was exceeded.	Increase to a less restrictive setting.
E27	Axis Not Homed	Absolute positioning was attempted without homing.	Verify homing sequence.

Error Code	Problem or Symptom	Possible Cause(s)	Action/Solution
E28	Motor Parameter Error	Parameter loaded from smart encoder or received from SERCOS controller is incompatible with the drive.	<ul style="list-style-type: none"> • Select a different motor through the SERCOS controller. • Select a different motor.
E29	Encoder Output Frequency Exceeded	Encoder output frequency exceeds the maximum user specified value. This only applies when the encoder output is synthesized by the drive.	<ul style="list-style-type: none"> • Increase the encoder output maximum frequency parameter. • Decrease the encoder interpolation parameter. • Increase the encoder output divider parameter.
E30	Encoder Communication Fault	Communication was not established with an intelligent encoder.	<ul style="list-style-type: none"> • Verify motor selection. • Verify the motor supports automatic identification. • Verify motor encoder wiring.
E31	Encoder Data	Encoder data is corrupted.	Replace the motor/encoder.
E32	Sine/Cosine Encoder Frequency Limit Exceeded	Maximum frequency of the sine/cosine circuitry has been exceeded.	<ul style="list-style-type: none"> • Decrease velocity. • Use encoder with lower resolution (before interpolation).
E33	Absolute Position Exceeds Position Rollover	Motion is commanded to a position outside the position rollover range. <ul style="list-style-type: none"> • An absolute index is initiated that specifies a position outside the position rollover range. • A homing cycle is initiated with the home position outside the position rollover range. • A define home is initiated with the home position outside the position rollover range. • A preset position is initiated that specifies a position outside the position rollover range. 	Set motion command to a position within the position rollover range.
E34	Ground Fault	Wiring error.	Check motor power wiring.
		Motor internal ground short.	Replace motor.
		Internal malfunction.	Disconnect motor power cable from drive and enable drive with current limit set to 0. If fault remains, call your A-B representative. If fault clears, then a wiring error or motor internal problem exists.
E35	Precharge Fault	Low AC input voltage.	Check input AC voltage on all phases.
		Internal malfunction.	Call your A-B representative.
E36	Power Circuitry Overtemperature	Excessive heat exists in the power circuitry.	<ul style="list-style-type: none"> • Reduce acceleration rates. • Reduce duty cycle (ON/OFF) of commanded motion. • Increase time permitted for motion. • Use larger Ultra3000 and motor. • Check tuning.
E37	AC Line Loss	One or more phases of the input AC power is missing.	Check input AC voltage on all phases.
E38	RESERVED		Call your local Allen-Bradley representative.

Error Code	Problem or Symptom	Possible Cause(s)	Action/Solution
E39	Self-sensing Commutation Startup Error	Motion required for self-sensing startup commutation was obstructed.	<ul style="list-style-type: none"> Verify that there are no impediments to motion at startup, such as hard limits. Increase self-sensing current if high friction or load conditions exist. Check motor or encoder wiring using wiring diagnostics.
E40	230V Shunt Protection Fault	Ineffective shunt resistor Excessive regeneration	<ul style="list-style-type: none"> Verify that the shunt resistor (internal or external) is connected. If an external shunt resistor is connected, verify that the shunt fuse is not blown.
E41	460V Shunt Protection Fault	Ineffective shunt resistor Excessive regeneration	<ul style="list-style-type: none"> If a non Allen-Bradley external shunt resistor is used, verify that the resistance value is within specifications. Verify that the motor is not being driven mechanically, causing the motor to behave as a generator.
E42	Motor Keying Error (SERCOS drives only)	The motor physically connected to the drive differs from the motor specified in the user program.	Select the correct motor in the user program.
E43	Drive Enable Input (SERCOS drives only)	<ul style="list-style-type: none"> An attempt was made to enable the axis through software while the Drive Enable hardware input was inactive. The Drive Enable input transitioned from active to inactive while the axis was enabled. 	<ul style="list-style-type: none"> Disable the Drive Enable Input fault. Verify that Drive Enable hardware input is active whenever the drive is enabled through software.
E50	Duplicate Node Fault (SERCOS drives only)	Duplicate node address detected on SERCOS ring.	Verify that each SERCOS drive is assigned a unique node address.
All others	RESERVED		Call your local Allen-Bradley representative.

Troubleshooting for SERCOS Drives

SERCOS Module Status LED

Use the table below for troubleshooting the SERCOS Module Status LED on your Ultra3000 (2098-DSD-xxx-SE or -HVxxx-SE).

If the SERCOS Module Status LED is:	Status is:	Potential Cause is:	Possible Resolution is:
Steady Green	Normal	Drive is enabled.	Normal operation when drive is enabled.
Flashing Green	Standby	Drive is not enabled.	Normal operation when drive is disabled.
Flashing Red-Green	DC Bus Undervoltage	The DC bus voltage is low.	<ul style="list-style-type: none"> Normal operation when using auxiliary power (main AC power is not applied). When using main AC power, refer to the section <i>Error Codes</i> to continue troubleshooting.
Flashing Red	Minor fault	Drive is faulted, but the fault can be cleared.	Refer to the section <i>Error Codes</i> to continue troubleshooting.
Steady Red	Unrecoverable fault	Drive is faulted, and the fault cannot be cleared.	Contact your local Allen-Bradley representative.

SERCOS Network Status LED

Use the table below for troubleshooting the SERCOS Network Status LED on your Ultra3000 (2098-DSD-xxx-SE or -HVxxx-SE).

If the SERCOS Network Status LED is:	Status is:	Potential Cause is:	Possible Resolution is:
Steady Green	Communication ready	No faults or failures.	N/A
Flashing Green	Establishing communication	System is still in the process of establishing SERCOS communication.	Wait for steady green LED status.
		Node address setting on the drive module does not match SERCOS controller configuration.	Verify proper node switch setting.
Flashing Red	No communication ¹	Loose fiber optic connection.	Verify proper fiber optic cable connections.
		Broken fiber optic cable.	Replace fiber optic cable.
		Receive fiber optic cable connected to SERCOS transmit connector and vice versa.	Check proper SERCOS fiber optic cable connections.

¹ Refer to *Fiber Optic Cable Installation and Handling Instructions* (publication 2090-IN010x-EN-P) for more information.

Troubleshooting for DeviceNet Drives

DeviceNet Module Status LED

Use the table below for troubleshooting the DeviceNet Module Status LED on your Ultra3000 (2098-DSD-xxx-DN, -xxxX-DN, -HVxxx-DN, or -HVxxxX-DN).

If the Module Status LED is:	Status is:	Potential Cause is:	Possible Resolution is:
Off	Not powered	No power	There is no power going to the device.
Steady-Green	Operational	Normal operation	Normal operation - no action needed.
Flashing-Green	Device is in stand-by	Processing or waiting for input	Normal operation - no action needed.
Flashing-Red	Recoverable fault	Not operational	Power cycle or reset the drive.
Steady-Red	Unrecoverable fault	Drive problem	1. Check drive for power-up error. 2. Replace drive.
Flashing-Red/ Green	Self testing	Self-test in progress	The device is in self test, wait.

DeviceNet Network Status LED

Use the table below for troubleshooting the DeviceNet Network Status LED on your Ultra3000 (2098-DSD-xxx-DN, -xxxX-DN, -HVxxx-DN, or -HVxxxX-DN).

If the Network Status LED is:	Status is:	Potential Cause is:	Possible Resolution is:
Off	<ul style="list-style-type: none"> Not powered Not on-line 	<ul style="list-style-type: none"> No power going to the device Failed Duplicate MAC ID check 	<ol style="list-style-type: none"> Check the Module Status LED to verify that the drive is powered. Check that one or more nodes are communicating on the network. Check that at least one other node on the network is operational and the data rate is the same as the drive.
Flashing-green	<ul style="list-style-type: none"> On-line Not connected 	<ul style="list-style-type: none"> Passed Duplicate MAC ID check No connection established 	No action is needed. The LED is flashing to signify that there are no open communication connections between the drive and any other device. Any connection (I/O or explicit message) made to the drive over DeviceNet will cause the LED to stop flashing and remain Steady-ON for the duration of any open connection.
Steady-green	<ul style="list-style-type: none"> On-line Connected 	One or more connections established	No action needed. This condition is normal.
Flashing-red	<ul style="list-style-type: none"> On-line Time-out 	I/O connection timed out	<ol style="list-style-type: none"> Re-initiate I/O messaging by the master controller. Reduce traffic or errors on the network so that messages can get through within the necessary time frame.
Steady-red	Network Failure	<ul style="list-style-type: none"> Failed Duplicate MAC ID check Bus-off 	<ol style="list-style-type: none"> Ensure that all nodes have unique addresses. If all node addresses are unique, examine network for correct media installation. Ensure that all nodes have the same Data Rate.

Specifications and Dimensions

Chapter Objectives

This appendix covers the following topics:

- Certifications
- Ultra3000 Power Specifications
- Ultra3000 General Specifications
- Dimensions

Certifications

The Ultra3000 is certified for the following when the product or package is marked.

- UL listed to U.S. and Canadian safety standards (UL 508 C File E145959)
- CE marked for all applicable directives

Note: Refer to www.ab.com/certification/ce/docs for more information.

Ultra3000 Power Specifications

The following sections provide power specifications for the Ultra3000.

Ultra3000 (230V) Power Specifications

The table below lists general power specifications and requirements for the Ultra3000 230V drives (2098-DSD-005x-xx, -010x-xx, and -020x-xx).

Specification	Description		
	2098-DSD-005	2098-DSD-010	2098-DSD-020
AC Input Voltage ¹	100-240V _{rms} Single Phase		
AC Input Frequency	47 - 63 Hz		
AC Input Current ^{2, 3} Nominal Maximum inrush (230V ac input)	5A _{rms} 100A (0-peak)	9A _{rms} 100A (0-peak)	18A _{rms} 100A (0-peak)
Continuous Output Current	2.5A (0-peak)	5A (0-peak)	10A (0-peak)
Intermittent Output Current	7.5A (0-peak)	15A (0-peak)	30A (0-peak)
Bus Capacitance	1410 μF	1880 μF	1880 μF
Internal Shunt Resistance	N/A	N/A	N/A
Shunt On	N/A	N/A	N/A
Shunt Off	N/A	N/A	N/A
Bus Overvoltage	400V dc	400V dc	400V dc
Energy Absorption Capability 115V ac input 230V ac input	93 Joules 38 Joules	125 Joules 51 Joules	
Continuous Power Output 115V ac input 230V ac input	0.25 kW 0.5 kW	0.5 kW 1.0 kW	1.0 kW 2.0 kW

¹ Specification is for nominal voltage. The absolute limits are ±10%, or 88-265V_{rms}.

² The 2098-005x-xx, -010x-xx, and -020x-xx (230V) drives are limited to one contactor cycles per two minutes.

³ Power initialization requires a short period of inrush current. Dual element time delay (slow blow) fuses are recommended (refer to *Fuse Specifications* on page A-5).

IMPORTANT

Only the 2098-DSD-005, -010, and -020 models support an auxiliary +5V logic supply since an auxiliary AC input is not available. Refer to *Auxiliary 5V Logic Supply* on page 2-26 for more information.

The table below lists general power specifications and requirements for the Ultra3000 230V drives (2098-DSD-030x-xx, -075x-xx, and -150x-xx).

Specification	Description		
	2098-DSD-030	2098-DSD-075	2098-DSD-150
AC Input and Auxiliary Input Voltage ¹	100-240V _{rms} Single-Phase	100-240V _{rms} Three-Phase	
AC Input Frequency	47 - 63 Hz		
Main AC Input Current ^{2, 4} Nominal, Maximum inrush, 230V ac input	28A _{rms} 50A (0-peak)	30A _{rms} 50A (0-peak)	46A _{rms} 68A (0-peak)
Auxiliary AC Input Current Nominal, 115V ac input Nominal, 230V ac input Maximum inrush, 115V ac input ³ Maximum inrush, 230V ac input ³	1.0A _{rms} 0.5A _{rms} 47A (0-peak) 95A (0-peak)	1.0A _{rms} 0.5A _{rms} 47A (0-peak) 95A (0-peak)	1.0A _{rms} 0.5A _{rms} 47A (0-peak) 95A (0-peak)
Continuous Output Current	15A (0-peak)	35A (0-peak)	65A (0-peak)
Intermittent Output Current	30A (0-peak)	75A (0-peak)	150A (0-peak)
Bus Capacitance	2370 μF	4290 μF	7520 μF
Internal Shunt Resistance	35 Ohms	16.5 Ohms	9.1 Ohms
Shunt On	420V dc	420V dc	420V dc
Shunt Off	402V dc	402V dc	402V dc
Bus Overvoltage	452V dc	452V dc	452V dc
Internal Shunt Continuous power Peak power	50W 4.5 kW	50W 10 kW	180W 18 kW
External Shunt Resistance Continuous power Peak power	30 Ohms (-0/+5%) 2.4 kW 6 kW	16.5 Ohms (-0/+5%) 4 kW 10 kW	9 Ohms (-0/+5%) 8 kW 19 kW
Energy Absorption Capability 115V ac input 230V ac input	211 Joules 117 Joules	381 Joules 211 Joules	669 Joules 370 Joules
Continuous Power Output 115V ac input 230V ac input	1.5 kW 3 kW	3.75 kW 7.5 kW	7.5 kW 15 kW

¹ Specification is for nominal voltage. The absolute limits are ±10%, or 88-265V_{rms}.

² The 2098-DSD-030x-xx, -075x-xx, and -150x-xx (230V) drives are limited to one contactor cycles per two minutes.

³ 400 μs half wave sine.

⁴ Power initialization requires a short period of inrush current. Dual element time delay (slow blow) fuses are recommended (refer to *Fuse Specifications* on page A-5).

Ultra3000 (460V) Power Specifications

The table below lists general power specifications and requirements for the Ultra3000 460V drives (2098-DSD-HV030x-xx, -HV050x-xx, -HV100x-xx, -HV150x-xx, and -HV220x-xx).

Specification	Description				
	2098-DSD-HV030	2098-DSD-HV050	2098-DSD-HV100	2098-DSD-HV150	2098-DSD-HV220
AC Input and Auxiliary Input Voltage ^{1, 2}	230-480V _{rms} Three Phase				
AC Input Frequency	47 - 63 Hz				
Main AC Input Current ^{3, 5} Nominal, 460V ac input Maximum inrush, 460V ac input	4A _{rms} 6A _{rms}	7A _{rms} 6A _{rms}	14A _{rms} 6A _{rms}	20A _{rms} 6A _{rms}	28A _{rms} 6A _{rms}
Auxiliary AC Input Current Nominal, 230V ac input Nominal, 360V ac input Nominal, 480V ac input Maximum inrush, 230V ac input ⁴ Maximum inrush, 480V ac input ⁴	0.55A _{rms} 0.35A _{rms} 0.25A _{rms} 47A (0-peak) 68A (0-peak)	0.55A _{rms} 0.35A _{rms} 0.25A _{rms} 47A (0-peak) 68A (0-peak)	0.55A _{rms} 0.35A _{rms} 0.25A _{rms} 47A (0-peak) 68A (0-peak)	0.55A _{rms} 0.35A _{rms} 0.25A _{rms} 47A (0-peak) 68A (0-peak)	0.55A _{rms} 0.35A _{rms} 0.25A _{rms} 47A (0-peak) 68A (0-peak)
Continuous Output Current	7A (0-peak)	11A (0-peak)	23A (0-peak)	34A (0-peak)	47A (0-peak)
Intermittent Output Current	14A (0-peak)	22A (0-peak)	46A (0-peak)	68A (0-peak)	94A (0-peak)
Bus Capacitance	470 µF	470 µF	705 µF	940 µF	1880 µF
Internal Shunt Resistance	120 Ohms	120 Ohms	40 Ohms	25 Ohms	20 Ohms
Shunt On	800V dc	800V dc	800V dc	800V dc	800V dc
Shunt Off	750V dc	750V dc	750V dc	750V dc	750V dc
Bus Overvoltage	810V dc	810V dc	810V dc	810V dc	810V dc
Internal Shunt Continuous power Peak power	100W 5.3 kW	100W 5.3 kW	200W 16 kW	200W 25.6 kW	400W 32 kW
External Shunt Resistance (-0/+5%) Continuous power Peak power	120 Ohms 3 kW 5.3 kW	120 Ohms 5 kW 5.3 kW	40 Ohms 10 kW 16 kW	25 Ohms 15 kW 25.6 kW	20 Ohms 22 kW 32 kW
Energy Absorption Capability 230V ac input with 230V motor 230V ac input with 460V motor 460V ac input	15 Joules 129 Joules 55 Joules	15 Joules 129 Joules 55 Joules	22 Joules 194 Joules 82 Joules	29 Joules 259 Joules 109 Joules	59 Joules 517 Joules 219 Joules
Continuous Power Output 230V ac input 460V ac input	1.5 kW 3.0 kW	2.5 kW 5.0 kW	5.0 kW 10 kW	7.5 kW 15 kW	11 kW 22 kW

¹ Specification is for nominal voltage. The absolute limits are ±10%, or 207-528V_{rms}.

² The 2098-DSD-HVxxx-xx drives can be powered with 230-240V_{rms} in order to be used in conjunction with motors designed for 230V operation. In such cases, the voltage levels used for shunting and DC bus overvoltage limits are adjusted to be compatible with the voltage limit of the motor.

³ The 2098-DSD-HVxxx-xx (460V) drives are limited to three contactor cycles per minute.

⁴ 400 µs half wave sine.

⁵ Power initialization requires a short period of inrush current (processor controlled via soft start circuitry). Dual element time delay (slow blow) fuses are recommended (refer to *Fuse Specifications* on page A-5).

Fuse Specifications

Use class CC, G, J, L, R, or T class fuses, with current ratings as indicated in the table below. The table below lists fuse examples recommended for use with the Ultra3000 (230V and 460V) drives.

Refer to *Power Wiring Requirements* in *Chapter 3* for input wire size.

Catalog Number	Input Voltage	Voltage Type	Recommended Fuse	
			Class CC ¹	Class J ¹
2098-DSD-005x-xx	230V	Input Power	FNQ-R-6	LPJ-6SP
2098-DSD-010x-xx			FNQ-R-10	LPJ-10SP
2098-DSD-020x-xx			FNQ-R-20	LPJ-20SP
2098-DSD-030x-xx			FNQ-R-30	LPJ-30SP
2098-DSD-075x-xx			FNQ-R-30	LPJ-30SP
2098-DSD-150x-xx			N/A	LPJ-60SP
2098-DSD-xxxx-xx		Auxiliary Input Power	FNQ-R-10	LPJ-10SP
2098-DSD-HV030x-xx	460V	Input Power	KTK-R-5	LPJ-5SP
2098-DSD-HV050x-xx			KTK-R-8	LPJ-8SP
2098-DSD-HV100x-xx			KTK-R-20	LPJ-17-1/2SP
2098-DSD-HV150x-xx			KTK-R-30	LPJ-30SP
2098-DSD-HV220x-xx			N/A	LPJ-35SP
2098-DSD-HVxxxx-xx		Auxiliary Input Power	FNQ-R-10	LPJ-10SP

¹ Bussmann® Fuse

IMPORTANT

Follow the wire size information as shown in the *Power Wiring Requirements* table on page 3-13 and select the fuse for the appropriate temperature rating of the wire. Auxiliary input fuses must not exceed 13A.

Circuit Breaker Specifications

While circuit breakers offer some convenience, there are limitations for their use. Circuit breakers do not handle high current inrush as well as fuses. The Ultra3000 needs to be protected by a device having a short circuit interrupt current rating of the service capacity provided or a maximum of 100,000A.

The wiring interconnection in Figure A.1 provide examples of the needed protection and follows UL and NEC codes. Full compliance is dependent on final wiring design and installation.

Figure A.1
Circuit Protection under NEC 1999 110-10 (preferred fully rated devices)

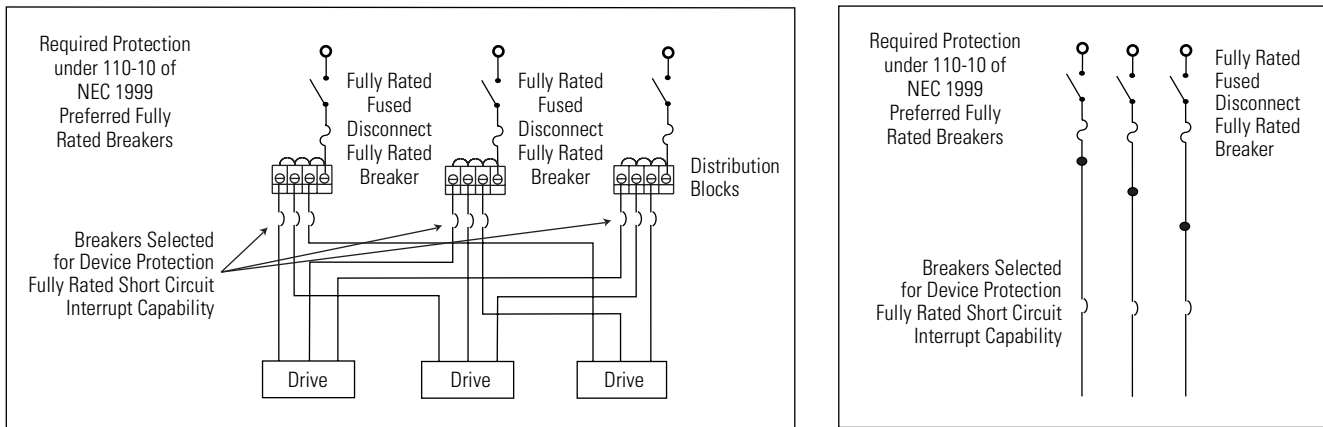

The table below lists circuit breaker examples recommended for use with the Ultra3000 (460V) drives.

Catalog Number	Input Voltage	Circuit Breakers
2098-DSD-HV030x-xx	460V	140M-F8E-C16
2098-DSD-HV050x-xx		140M-F8E-C20
2098-DSD-HV100x-xx		140M-F8E-C32
2098-DSD-HV150x-xx		140M-F8E-C45
2098-DSD-HV220x-xx		N/A

ATTENTION



Bulletin 140M circuit breakers should not be used on the output of an ac drive as an isolating disconnect switch or motor overload device. These devices are designed to operate on sine wave voltage and the drive's PWM waveform does not allow it to operate properly. As a result, damage to the device will occur.

Contactor Ratings

The table below lists contactor examples recommended for use with the Ultra3000 (460V) drives.

Catalog Number	Input Voltage	Contactor
2098-DSD-HV030x-xx	460V	100-C23x10 (AC Coil) 100-C23Zx10 (DC Coil)
2098-DSD-HV050x-xx		100-C30x10 (AC Coil) 100-C30Zx10 (DC Coil)
2098-DSD-HV100x-xx		100-C37x10 (AC Coil) 100-C37Zx10 (DC Coil)
2098-DSD-HV150x-xx		100-C43x10 (AC Coil) 100-C43Zx10 (DC Coil)
2098-DSD-HV220x-xx		100-C60x10 (AC Coil) 100-C60Zx10 (DC Coil)

Power Dissipation Specifications

Use the following table to size an enclosure and calculate required ventilation for the Ultra3000. Typical heat losses run approximately one-half maximum power losses. The maximum power losses are shown below.

Catalog Number	Maximum Loss Watts
2098-DSD-005x-xx	48
2098-DSD-010x-xx	48
2098-DSD-020x-xx	50
2098-DSD-030x-xx	150 + dissipative shunt
2098-DSD-075x-xx	300 + dissipative shunt
2098-DSD-150x-xx	500 + dissipative shunt

Catalog Number	Maximum Loss Watts
2098-DSD-HV030x-xx	175 + dissipative shunt
2098-DSD-HV050x-xx	175 + dissipative shunt
2098-DSD-HV100x-xx	350 + dissipative shunt
2098-DSD-HV150x-xx	350 + dissipative shunt
2098-DSD-HV220x-xx	600 + dissipative shunt

Ultra3000 General Specifications

The following sections provide physical, environmental, control, I/O, communication, feedback, connector, and AC line filter specifications for the Ultra3000 drives.

Physical and Environmental Specifications

Specification	Description		Specification	Description	
Weight			Weight		
2098-DSD-005x-xx	1.8 kg	(4.1 lbs)	2098-DSD-HV030x-xx	8.55 kg	(18.8 lbs)
2098-DSD-010x-xx	2.1 kg	(4.6 lbs)	2098-DSD-HV050x-xx	8.55 kg	(18.8 lbs)
2098-DSD-020x-xx	2.1 kg	(4.6 lbs)	2098-DSD-HV100x-xx	10.44 kg	(22.96 lbs)
2098-DSD-030x-xx	6.2 kg	(13.6 lbs)	2098-DSD-HV150x-xx	10.44 kg	(22.96 lbs)
2098-DSD-075x-xx	9.3 kg	(20.6 lbs)	2098-DSD-HV220x-xx	14.1 kg	(31.0 lbs)
2098-DSD-150x-xx	14.1 kg	(31.0 lbs)			
Ambient Temperature	Storage: -40° C to 70° C (-40° F to 158° F) Operation: 0° C to 55° C (32° F to 131° F)				
Relative Humidity	5-95% non-condensing				
Altitude	1500 m (4921.5 ft) - Derate 3% per 300 m (984.3 ft) above 1500 m (4,921.5 ft)				
Vibration	5-2000 Hz @ 2.5g peak, 0.0006 mm (0.015 in.) maximum displacement				
Shock	15g, 11 ms half-sine				

Control Specifications

Specification	Description
Commutation	3-Phase Sinusoidal, Space Vector Modulated (SVM)
Current Regulator	Digital PI - 125 μ s update rate
Velocity Regulator	Digital PID - 250 μ s update rate
Position Regulator	Digital PID with feed-forward - 1 ms update rate
PWM	4 or 8 kHz, space vector modulation
Velocity Loop Bandwidth (maximum)	300 Hz

Inputs and Outputs Specifications

Specification	Description
Digital Inputs	8 Optically Isolated 12-24V Inputs, Active High, Current Sinking
Digital Outputs	4 Optically Isolated 12-24V Outputs, Active High, Current Sourcing
Relay Output	1 Normally Open Relay - 30V dc Maximum Voltage, 1A Maximum Current
I/O Response	100 μ sec
Digital I/O Firmware Scan Period	1 mS
Analog Inputs COMMAND ILIMIT	14 bit A/D, ± 10 V 10 bit A/D, 0 to 10V
Analog Output	± 10 V, 8 bits, 2 mA maximum

Communication Specifications

Specification	Description
SERCOS (option)	
Baud Rates	4 and 8 Mbit
Node Addresses	01-99
DeviceNet (option)	
Power Consumption from Network	60 mA
Data Rates	125, 250, and 500 kps, and auto-baud
Node Addresses	00-63
Messaging Capabilities	Explicit, Polled I/O, Change of State, and Cyclic Messaging
Serial	
Ports	One RS-232/RS-422/RS-485
Baud Rates	1200, 2400, 4800, 9600, 19200, and 38400 baud

Motor Feedback Specifications

Specification	Description
Encoder Types	Incremental, Sine/Cosine, Intelligent, and Absolute
Maximum Input Frequency	100 kHz (Sine/Cosine Input)
	2.5 MHz (TTL Input) per channel
Commutation Startup	Hall Sensor or None

Auxiliary Feedback Specifications

Specification	Description
Input Modes	A quad B, Step/Direction, CW/CCW
Maximum Signal Frequency	2.5 MHz
Input Types	Incremental only, (differential, single-ended, open collector ¹)

¹ Differential input types are recommended.

Connector Specifications

The table below lists connector specifications. Refer to *Appendix C* for a list of drive connectors available from other suppliers.

Connector	Description	Specification
CN1	User Input/Output	44-pin High Density Female D-Sub Connector
CN2	Motor Feedback Connector	15-pin High Density Female D-Sub Connector
CN3	Serial Port Connector	9-pin Female D-Sub Connector
TB1 and TB2	Main and Auxiliary AC, DC Bus, Motor Power, and Shunt Connectors	Screw Terminal Block

AC Line Filter Specifications

The following AC line filters are compatible with the Ultra3000 drives.

AC Line Filter Catalog Number	Specifications									
	Voltage	Phase	Current	Power Loss	Weight kg (lb)	Humidity	Vibration	Operating Temperature		
2090-UXLF-106	250V ac 50/60 Hz	Single	6A @ 50° C (122° F)	3.5W	0.3 (0.66)	90% RH	10-200 Hz @ 1.8 g	-25 to 85° C (-13 to 185° F)		
2090-UXLF-110			10A @ 50° C (122° F)	2.7W	0.95 (2.0)					
2090-UXLF-123			23A @ 50° C (122° F)	10W	1.6 (3.5)					
2090-UXLF-132			32A @ 50° C (122° F)	20W						
2090-UXLF-136			250V ac 50/60 Hz	Three	36A @ 50° C (122° F)				–	1.75 (3.9)
2090-UXLF-336					–				2.7 (5.9)	
2090-UXLF-350	50A @ 50° C (122° F)	–								
2090-UXLF-HV323	520V ac 50/60 Hz	Three	23A @ 50° C (122° F)	20W	1.6 (3.5)					
2090-UXLF-HV330			30A @ 50° C (122° F)	51W	1.8 (4.0)					
2090-UXLF-HV350			50A @ 50° C (122° F)	25W	4.8 (10.6)					

Use the table below to determine which AC line filter is best suited for your Ultra3000 drive (based on the length of the motor cables).

Ultra3000 Drives	AC Line Filter Catalog Number	
	Motor Cables < 30 m	Motor Cables > 30 m
2098-DSD-005x-xx	2090-UXLF-106	2090-UXLF-110
2098-DSD-010x-xx	2090-UXLF-110	2090-UXLF-110
2098-DSD-020x-xx	2090-UXLF-123	2090-UXLF-123
2098-DSD-030x-xx	2090-UXLF-136	2090-UXLF-132
2098-DSD-075x-xx	2090-UXLF-336	2090-UXLF-HV330
2098-DSD-150x-xx	2090-UXLF-350	2090-UXLF-HV350
2098-DSD-HV030x-xx 2098-DSD-HV050x-xx 2098-DSD-HV100x-xx 2098-DSD-HV150x-xx	2090-UXLF-HV323	2090-UXLF-HV323
2098-DSD-HV220x-xx	2090-UXLF-HV330	2090-UXLF-HV330

Ultra Family External Shunt Module Specifications

The following external shunt modules are compatible with the Ultra3000 drives with regenerative loads that exceed the capacity of the internal shunt resistor.

Ultra3000 Drives	Shunt Module Catalog Number	Specifications						Fuse Replacement
		Drive Voltage VAC	Resistance Ohms	Peak Power kW	Peak Current Amps	Continuous Power Watts	Shipping Weight kg (lbs)	
2098-DSD-005, 010, and 020	2090-UCSR-A300	230	36	4.0	10.5	300	1.51 (3.3)	—
2098-DSD-030	9101-1183		30	5.9	14.0	200	—	CCMR-4-½ ²
2098-DSD-075 and 150	2090-UCSR-P900		18	10	23.3	900	4.08 (9.0)	FWP-10A14F ¹
2098-DSD-HV030 and -HV050	2090-SR120-09	460	120	5.3	6.7		3.63 (8.0)	FWP-2.5A14F ¹
2098-DSD-HV100	2090-SR040-09		40	16	20.0	1800		8.6 (19.0)
	2090-SR040-18		40		20.0		FWP-10A14F ¹	
2098-xxx-HV150	M3575R-H27B0,C ³		25-31	25.6	31.0	900	11.3 (25.0)	N/A
	M3575R-H27BF,C ³					1800		N/A
2098-xxx-HV220	M3575R-H33BF,C ³	20-25	32.0	36.0	3600	12.7 (28.0)	N/A	

¹ Bussmann part number.

² Littelfuse® part number.

³ Bonitron part number. For more information contact:
Bonitron, Inc.
521 Fairground Court,
Nashville, TN 37211
Tel: (615) 244-2825
www.BONITRON.com

Maximum Feedback Cable Lengths

Although motor feedback cables are available in standard lengths up to 90 m (295.3 ft), the drive/motor/feedback combination may limit the maximum cable length, as shown in the tables below. These tables assume the use of cables recommended in the *Motion Control Selection Guide* (publication GMC-SG001x-EN-P).

The maximum cable lengths for Ultra3000 drives with MP-Series (low inertia and integrated gear) motors are given in the table below.

Drive Family	MPL-A (230V) Motors		MPL-B (460V) Motors		MPG-A (230V) Motors	MPG-B (460V) Motors
	Absolute High-Res ¹ m (ft)	Incremental ² m (ft)	Absolute High-Res ¹ m (ft)	Incremental ² m (ft)	Absolute High-Res ³ m (ft)	Absolute High-Res ³ m (ft)
Ultra3000	90 (295.3)	45 (147.6)	90 (295.3)	45 (147.6)	90 (295.3)	60 (196.8)

¹ Refers to MPL-A/BxxxS/M (single-turn or multi-turn) low inertia motors with absolute high-resolution feedback.

² Refers to MPL-A/BxxxH low inertia motors with 2000-line incremental feedback.

³ Refers to MPG-A/BxxxS/M (single-turn or multi-turn) integrated gear motors with absolute high-resolution feedback.

The maximum cable lengths for Ultra3000 drives with MP-Series food grade motors are given in the table below.

Drive Family	MPF-A (230V) Motors	MPF-B (460V) Motors
	Absolute High-Resolution ¹ m (ft)	Absolute High-Resolution ¹ m (ft)
Ultra3000	90 (295.3)	90 (295.3)

¹ Refers to MPF-A/BxxxS/M (single-turn or multi-turn) food grade motors with absolute high-resolution feedback.

The maximum cable lengths for Ultra3000 drives with 1326AB (M2L/S2L) and F-, H-, N-, and Y-Series motors are given in the table below.

Drive Family	1326AB (M2L/S2L) (460V) Motors	F-, H-, N-, or Y-Series (230V) Motors
	Absolute High-Resolution ¹ m (ft)	Incremental ² m (ft)
Ultra3000	90 (295.3)	30 (98.4)

¹ Refers to 1326AB-Bxxx-M2L/S2L (single-turn or multi-turn) motors with absolute high-resolution feedback.

² Refers to F-, H-, N-, or Y-Series motors with incremental (optical encoder) feedback.

Dimensions

The following diagrams show the dimensions and mounting hole locations for the Ultra3000 drives.

Ultra3000 (230V) Dimensions

In the figure below, -xxx is replaced by -005, -010, or -020 to represent the Ultra3000 500W, 1 kW, and 2 kW drives respectively.

Figure A.2

Ultra3000 (230V) Dimensions (2098-DSD-xxx, -xxxX, -xxx-SE, -xxx-DN, -xxxX-DN)

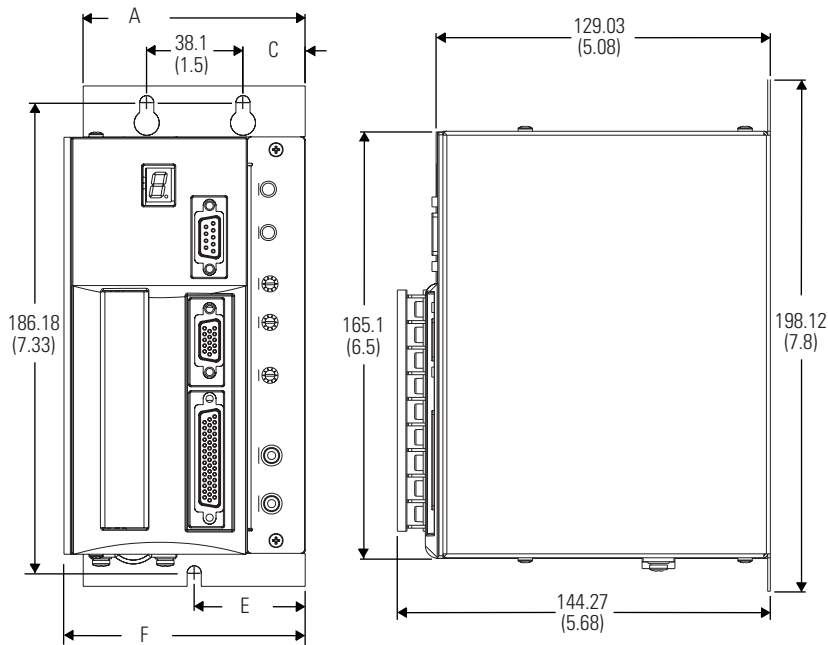

Dimensions are in millimeters (inches)

Unit shown is the 2098-DSD-005-SE

Ultra3000 Drive 2098-DSD	A	C	E	F
-005, -005X	65.02 (2.56)	13.26 (0.52)	32.77 (1.29)	72.64 (2.86)
-010, -010X, -020, -020X				98.1 (3.89)
-005-SE, 005-DN, and -005X-DN	87.88 (3.46)	24.64 (0.97)	43.94 (1.73)	95.5 (3.76)
-010-SE, -010-DN, -010X-DN, -020-SE, -020-DN, -020X-DN				121.54 (4.79)

In the figure below, -xxx is replaced by -030, -075, or -150 to represent the Ultra3000 3, 7.5, and 15 kW drives respectively.

Figure A.3
Ultra3000 (230V) Dimensions (2098-DSD-xxx, -xxxX, -xxx-SE, -xxx-DN, -xxxX-DN)

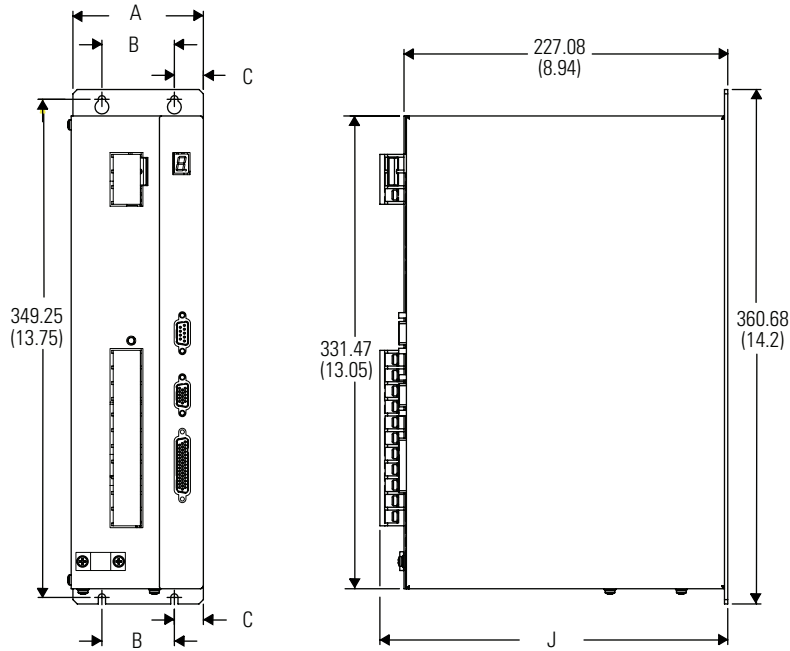

Dimensions are in millimeters (inches)

Unit shown is the 2098-DSD-030

Ultra3000 Drive 2098-DSD	A	B	C	J
-030, -030X, -030-SE, -030-DN, -030X-DN	91.44 (3.6)	50.8 (2.0)	20.32 (0.8)	243.84 (9.6)
-075, -075X, -075-SE, -075-DN, -075X-DN	138.68 (5.41)	88.9 (3.5)	24.89 (0.96)	247.14 (9.73)
-150, -150X, -150-SE, -150-DN, -150X-DN	188.97 (7.44)	139.7 (5.5)	24.6 (0.97)	241.05 (9.49)

Ultra3000 (460V) Dimensions

In the figure below, *xxx* is replaced by 030, 050, 100, 150, or 220 to represent the Ultra3000 3, 5, 10, 15, and 22 kW drives respectively.

Figure A.4
Ultra3000 (460V) Dimensions (2098-DSD-HV_{xxx}, -HV_{xxx}X, -HV_{xxx}-SE, -HV_{xxx}-DN, -HV_{xxx}X-DN)

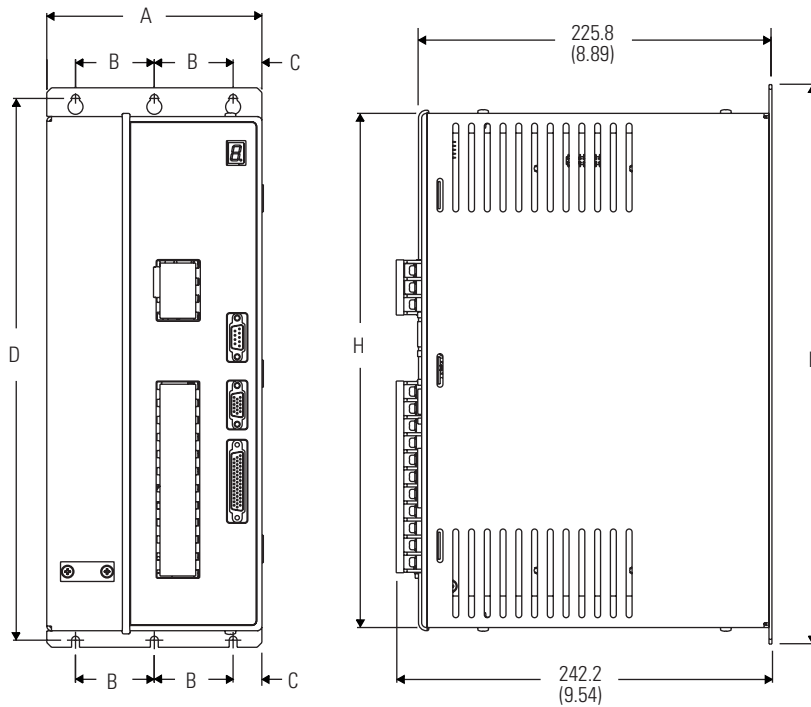

Dimensions are in millimeters (inches)

Unit shown is the 2098-DSD-HV030

Ultra3000 Drive ¹ 2098-DSD-HV	A	C	B	D	H	I
030x, 030-xx, 050x, 050-xx	138.7 (5.46)	18.5 (0.73)	50.8 (2.0)	349.3 (13.75)	331.5 (13.05)	360.7 (14.2)
100x, 100-xx, 150x, 150-xx	151.6 (5.97)	25 (0.99)				
220x, 220-xx	203.2 (8.0)	25.4 (1.0)	76.2 (3.0)	380.4 (14.98)	362.6 (14.26)	391.8 (15.43)

¹ The *x* represents the indexing (X) option. The *-xx* represents the SERCOS interface (SE) or DeviceNet (DN) option. SERCOS interface is not available with the DeviceNet option.

Interconnect Diagrams

Chapter Objectives

This appendix contains the following interconnect diagrams:

- Power Interconnect Diagrams
- Shunt Module Interconnect Diagrams
- Ultra3000/Motor Interconnect Diagrams
- Control String Examples (120V ac)
- Controlling a Brake Example
- Ultra3000 to Logix Cable and Interconnect Diagrams
- Ultra3000 to IMC-S Compact Cable and Interconnect Diagram

Ultra3000 Interconnect Diagram Notes

The notes in the table below apply to the power, drive/motor, shunt, and 120V ac control string interconnect diagrams.

ATTENTION



The National Electrical Code and local electrical codes take precedence over the values and methods provided. Implementation of these codes are the responsibility of the machine builder.

Note:	Information:
1	A disconnecting device is required for maintenance and safety. If a grounded neutral is used instead of L2, only L1 may be switched or fused.
2	An isolation transformer is optional. If the transformer secondary has a neutral connection, neutral must be bonded to ground. Multiple drive modules may be powered from one transformer or other AC supply source.
3	Do not daisy chain drive module power connections. Make separate connections directly to the AC supply.
4	For power wiring specifications, refer to <i>Power Wiring Requirements</i> in Chapter 3.
5	For input fuse sizes, refer to <i>Fuse Specifications</i> in Appendix A.
6	May be used to maintain power to logic section of drive and status LEDs when main AC input power is removed. A separate AC line source may be used if voltage is between 88-265V ac _{RMS} on 2098-DSD-xxx (230V drives) or 207-528V ac _{RMS} on 2098-DSD-HVxxx (460V drives).
7	For AC line filter specifications, refer to <i>AC Line Filter Specifications</i> in Appendix A.
8	Drive Enable input must be opened when main power is removed and auxiliary power is present, or a drive fault will occur. A delay of at least 1.0 second must be observed before attempting to enable the drive after main power is restored.
9	Cable shield clamp must be used in order to meet CE requirements. No external connection to chassis ground required.
10	<div style="display: flex; align-items: center;"> <div style="margin-right: 10px;"> <p>ATTENTION</p> </div> <p>Implementation of safety circuits and risk assessment is the responsibility of the machine builder. Please reference international standards EN1050 and EN954 estimation and safety performance categories. For more information refer to <i>Understanding the Machinery Directive</i> (publication SHB-900).</p> </div>
11	The recommended minimum wire size for wiring the safety circuit to the contactor enable connector is 1.5 mm ² (16 AWG).
12	For motor cable specifications and drive/motor cable combinations, refer to the <i>Motion Control Selection Guide</i> (publication GMC-SG001x-EN-P).
13	The Ultra3000 referenced is either a 2098-DSD-xxx or -xxxX (Ultra3000 with indexing), -xxx-SE (SERCOS interface), -xxx-DN (DeviceNet interface), -xxxX-DN (DeviceNet with indexing) 230V drive.
14	The Ultra3000 referenced is either a 2098-DSD-HVxxx or -HVxxxX (Ultra3000 with indexing), -HVxxx-SE (SERCOS interface), -HVxxx-DN (DeviceNet interface), -HVxxxX-DN (DeviceNet with indexing) 460V drive.
15	Wire colors are for flying lead cable (2090-XXNFxx-Sxx) and may vary from the premolded connector cable (2090-UXNFBxx-Sxx). Wires without terminations at the drive are not shown for clarity.
16	If flying lead feedback cable has a drain wire, it must be folded back and clamped with the cable shield (CN2 breakout board 2090-UXBB-DM15).
17	Only the MPG-Bxxx encoder uses the +5V dc supply. MPL-Bxxx and 1326AB (M2L/S2L) encoders use the +9V dc supply.
18	Only the MPL-A5xx and MPF-A5xx encoders use the +9V dc supply. MPG-Axxx encoders use the +5V dc supply.
19	Use a flyback diode for noise suppression of the motor brake coil. For more information, refer to <i>System Design for Control of Electrical Noise Reference Manual</i> (publication GMC-RM001x-EN-P).
20	Relay Output (CN1, pins 43 and 44) must be configured as Ready in Ultraware software.
21	The preferred method for supplying the auxiliary power is by using the 12- or 44-pin drive-mounted breakout board with 24V to 5V auxiliary power converter (catalog number 2090-U3CBB-DM12 or -DM44). Auxiliary +5V power is required to maintain encoder position when the main AC power is disconnected.

Power Interconnect Diagrams

The Ultra3000 (2098-DSD-005x-xx, -010x-xx, and -020x-xx) power wiring with 24V dc control string (non-SERCOS drives only) is shown in the figure below. To avoid a separate 5V dc auxiliary logic power supply, the 24V to 5V converter breakout board (2090-U3CBB-DMxx) is used to wire the control interface (CN1) connector. For the control string diagram with 120V ac input refer to Figure B.16.

For SERCOS drives, input line contactor is part of the PLC program and output control.

Figure B.1
Typical Power Wiring of Ultra3000 System
(2098-DSD-005x-xx, -010x-xx, and -020x-xx)

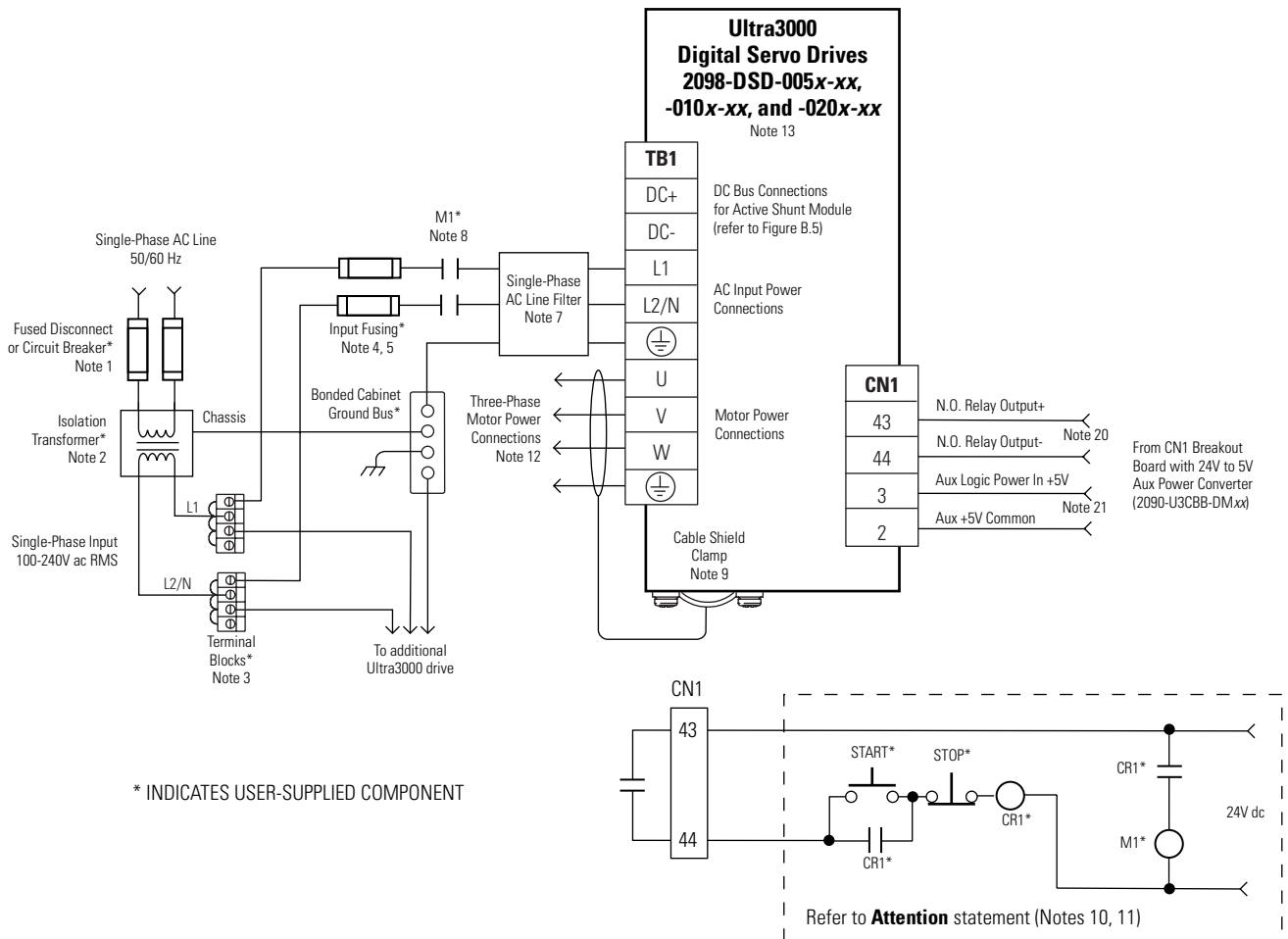

Note: Refer to Figure 2.26 in the chapter *Ultra3000 Connector Data* for more information on the relay output.

The Ultra3000 (2098-DSD-030x-xx) power wiring with 24V dc control string (non-SERCOS drives only) is shown in the figure below. For the control string diagram with 120V ac input refer to Figure B.17.

For SERCOS drives, input line contactor is part of the PLC program and output control.

Figure B.2
Typical Power Wiring of Ultra3000 System
(2098-DSD-030x-xx)

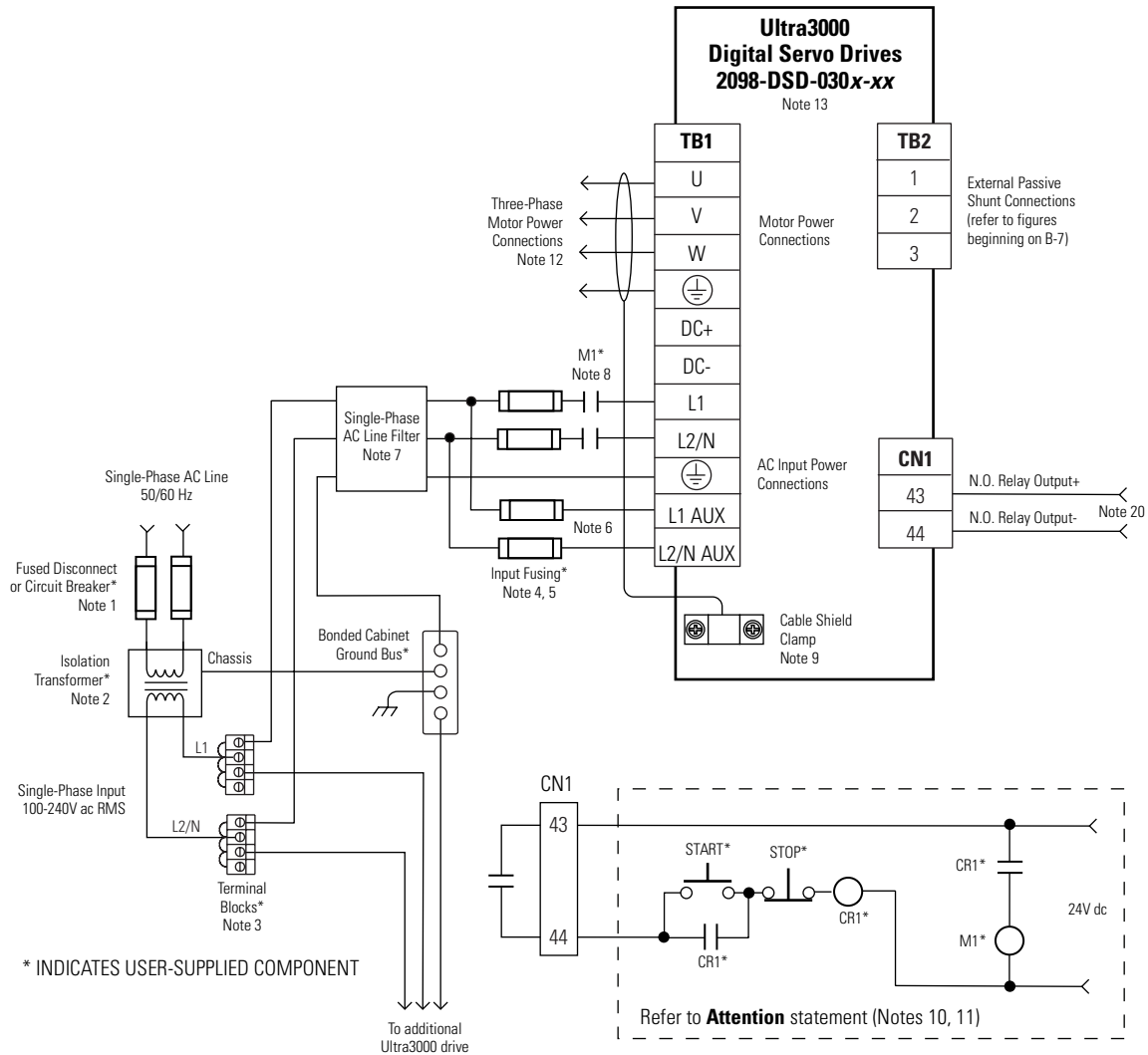

Note: Refer to Figure 2.26 in the chapter *Ultra3000 Connector Data* for more information on the relay output.

The Ultra3000 (2098-DSD-075x-xx and -150x-xx) power wiring with 24V dc control string (non-SERCOS drives only) is shown in the figure below. For the control string diagram with 120V ac input refer to Figure B.18.

For SERCOS drives, input line contactor is part of the PLC program and output control.

Figure B.3
Typical Power Wiring of Ultra3000 System
(2098-DSD-075x-xx and -150x-xx)

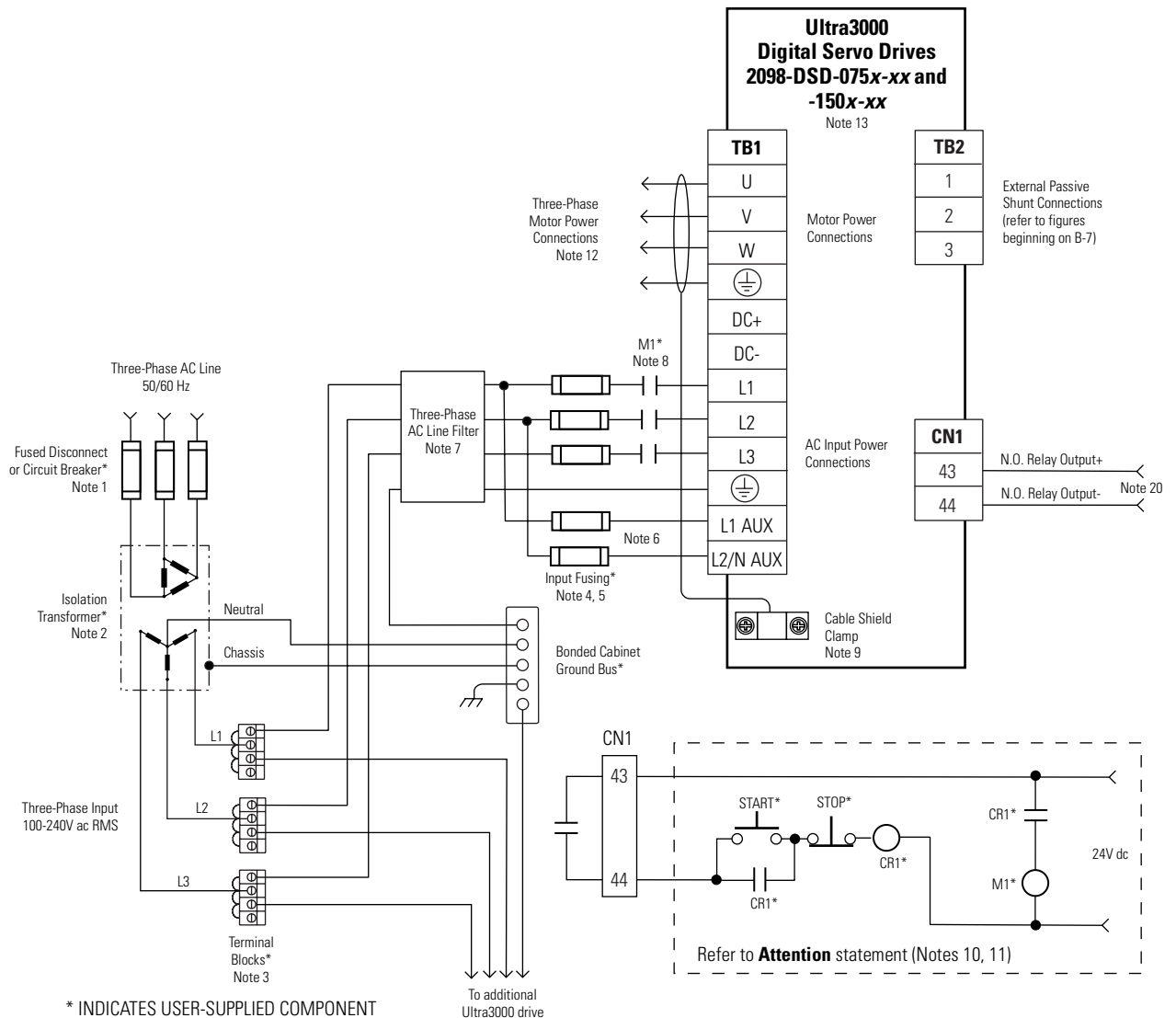

Note: Refer to Figure 2.26 in the chapter *Ultra3000 Connector Data* for more information on the relay output.

The Ultra3000 (2098-DSD-HVxxx-xx and -HVxxxX-xx) power wiring with 24V dc control string is shown in the figure below. For the control string diagram with 120V ac input refer to Figure B.18.

Figure B.4
Typical Power Wiring of Ultra3000 System
(2098-DSD-HVxxx-xx and -HVxxxX-xx)

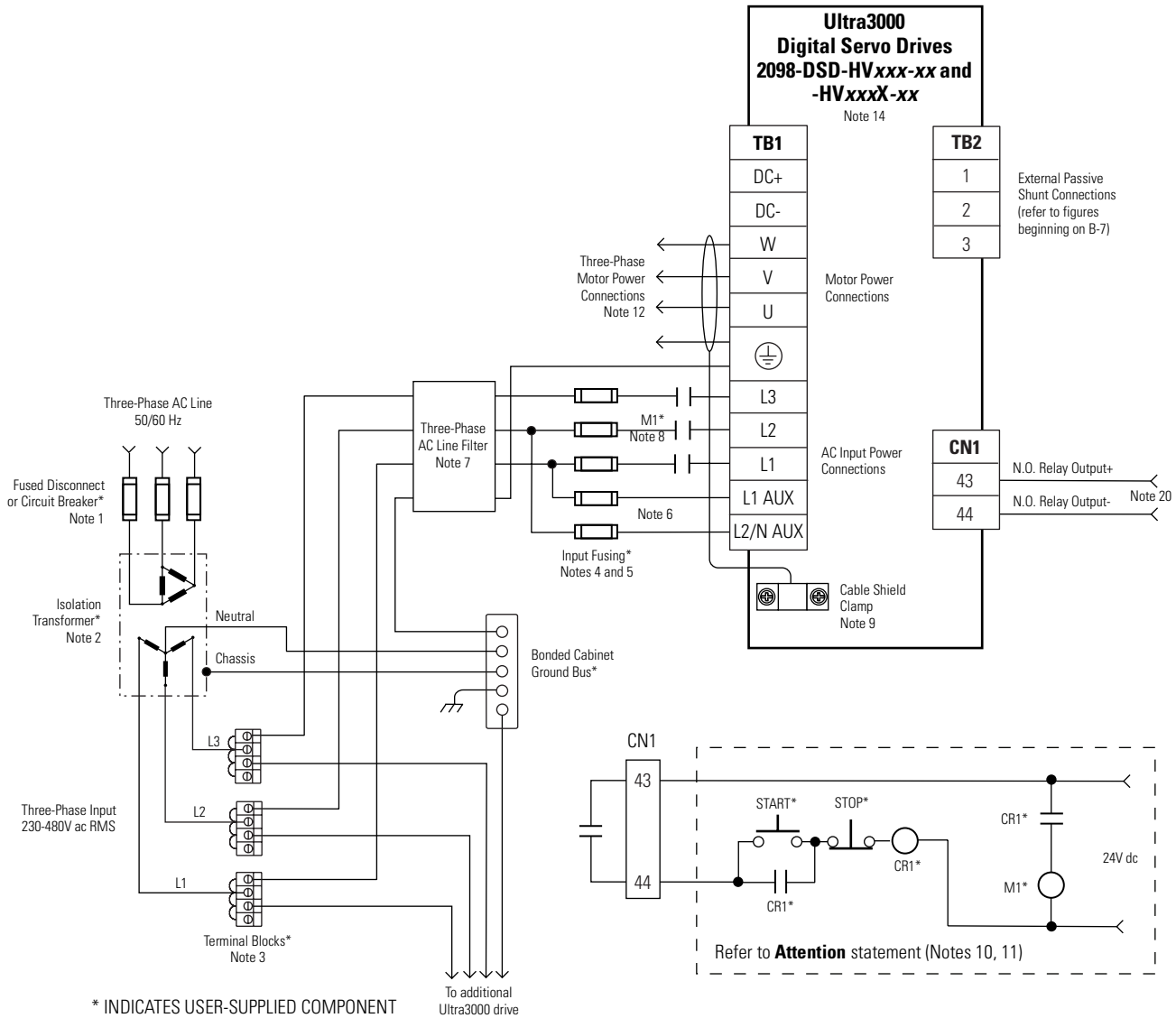

Note: Refer to Figure 2.26 in the chapter *Ultra3000 Connector Data* for more information on the relay output.

Shunt Module Interconnect Diagrams

This section contains the interconnect diagrams connecting the Ultra3000 drives with active and passive shunt modules. Refer to *External Shunt Kits* in *Appendix C* for Ultra3000/shunt combinations.

Active Shunt Module Diagrams

In the figure below, the Ultra3000 (2098-DSD-005x-xx, -010x-xx, or -020x-xx) is shown wired with the 2090-UCSR-A300 active shunt module.

Figure B.5
External Active Shunt Module Interconnect Diagram

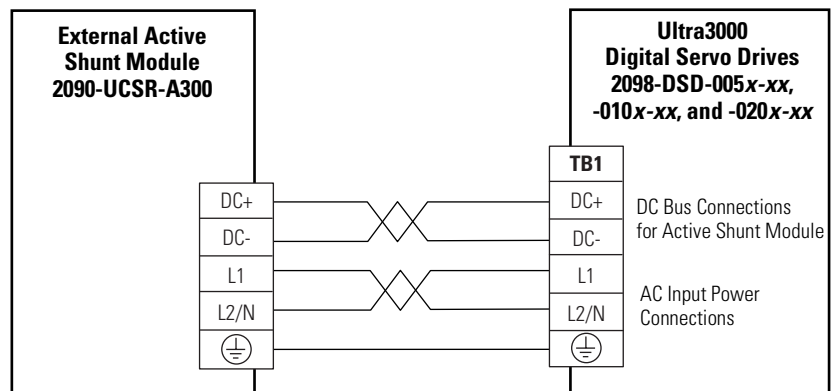

Passive Shunt Module Diagrams

In the Figure B.6, the Ultra3000 is shown wired for internal shunt operation. This is the factory default jumper setting.

IMPORTANT

Internal shunt operation is only present on the drives listed in the figure below.

Figure B.6
Internal Shunt Interconnect Diagram

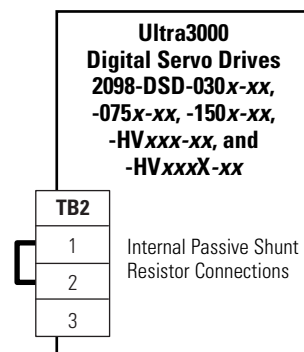

In the figure below, the Ultra3000 is shown wired with an external passive shunt resistor. Refer to *External Shunt Kits* in *Appendix C* for Ultra3000/shunt combinations.

Figure B.7
External Passive Shunt Module Interconnect Diagram

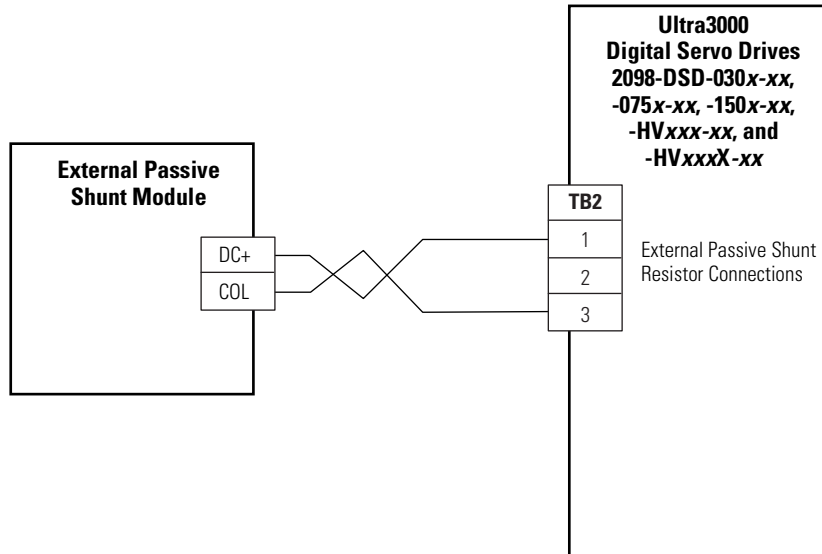

In the figure below, the Ultra3000 (2098-DSD-150x-xx) is shown wired with two external passive shunt resistors. When two 900W shunt modules are connected in parallel, the shunt capacity is doubled for a total of 1800W of continuous power dissipation.

Figure B.8
External Passive Shunt Module Interconnect Diagram

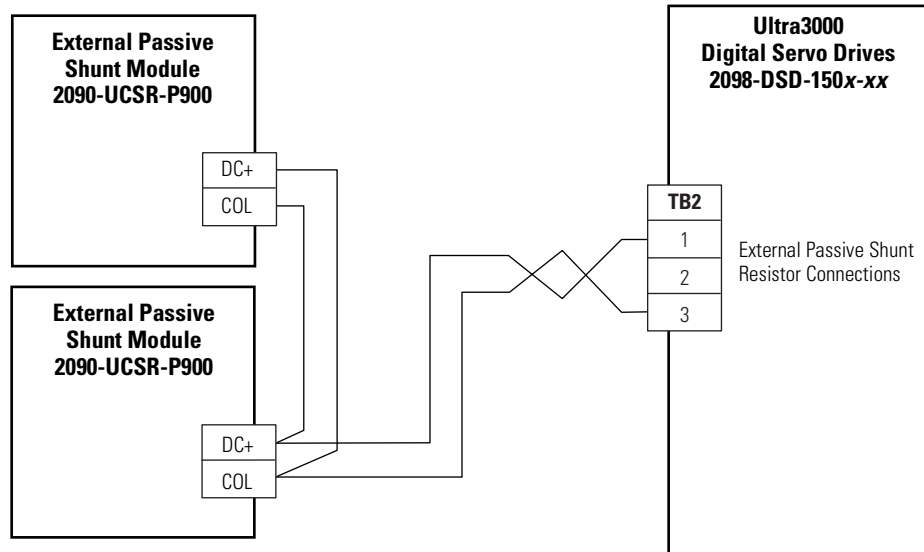

In the figure below, the Ultra3000 (2098-DSD-HV150x-xx or -HV220x-xx) is shown wired to a Bonitron shunt module.

Figure B.9
External Passive Shunt Module Interconnect Diagram

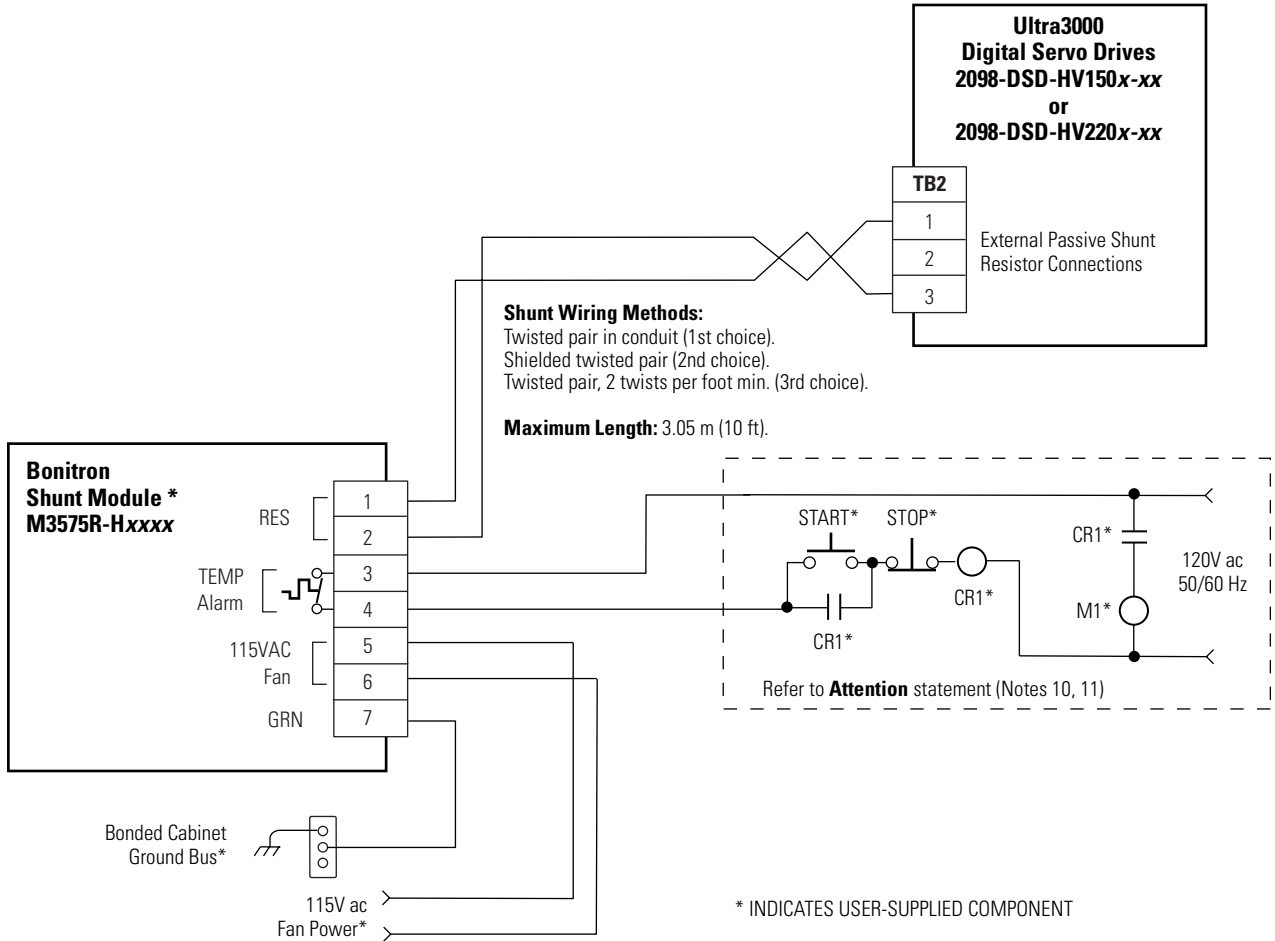

Ultra3000/Motor Interconnect Diagrams

This section contains the motor power, brake, and feedback signal interconnect diagrams between the Ultra3000 and MP-Series, 1326AB- (M2L/S2L), F-, H-, N-, and Y-Series motors.

In the figure below, the Ultra3000 (460V) is shown connected to MP-Series or 1326AB (M2L/S2L) servo motors.

Figure B.10
Ultra3000 to MP-Series or 1326AB (M2L/S2L) Motor Configuration

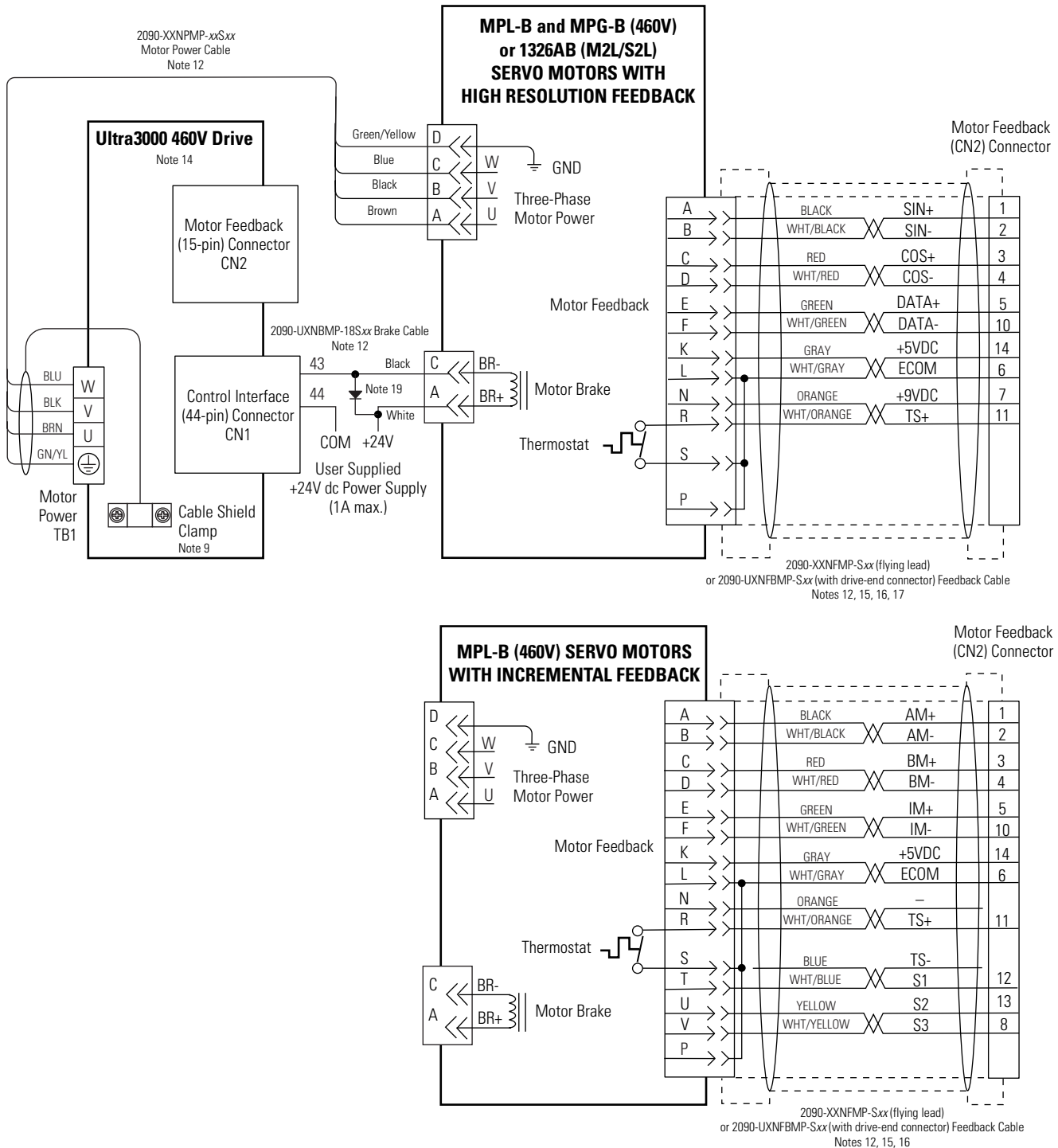

In the figure below, the Ultra3000 (230V) is shown connected to MP-Series (low inertia and integrated gear) 230V servo motors.

Figure B.11
Ultra3000 to MP-Series (230V) Motor Configuration

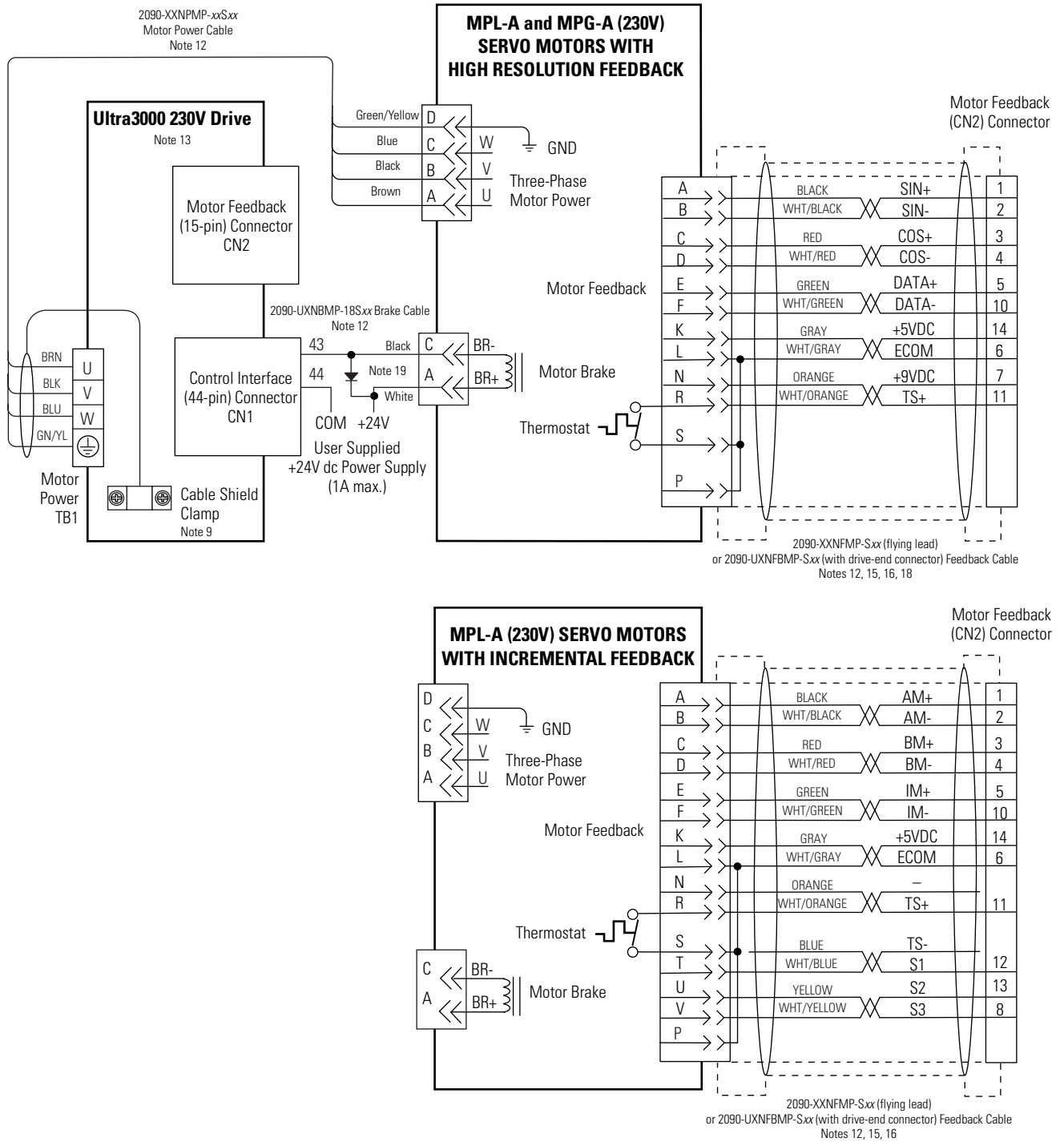

IMPORTANT

MPL-A5xxx motors are not compatible with Ultra3000 (2098-DSD-005, -010, -020) drives.

In the figure below, the Ultra3000 (230V) is shown connected to MP-Series food grade servo motors.

Figure B.12
Ultra3000 to MP-Series Food Grade Motor Configuration

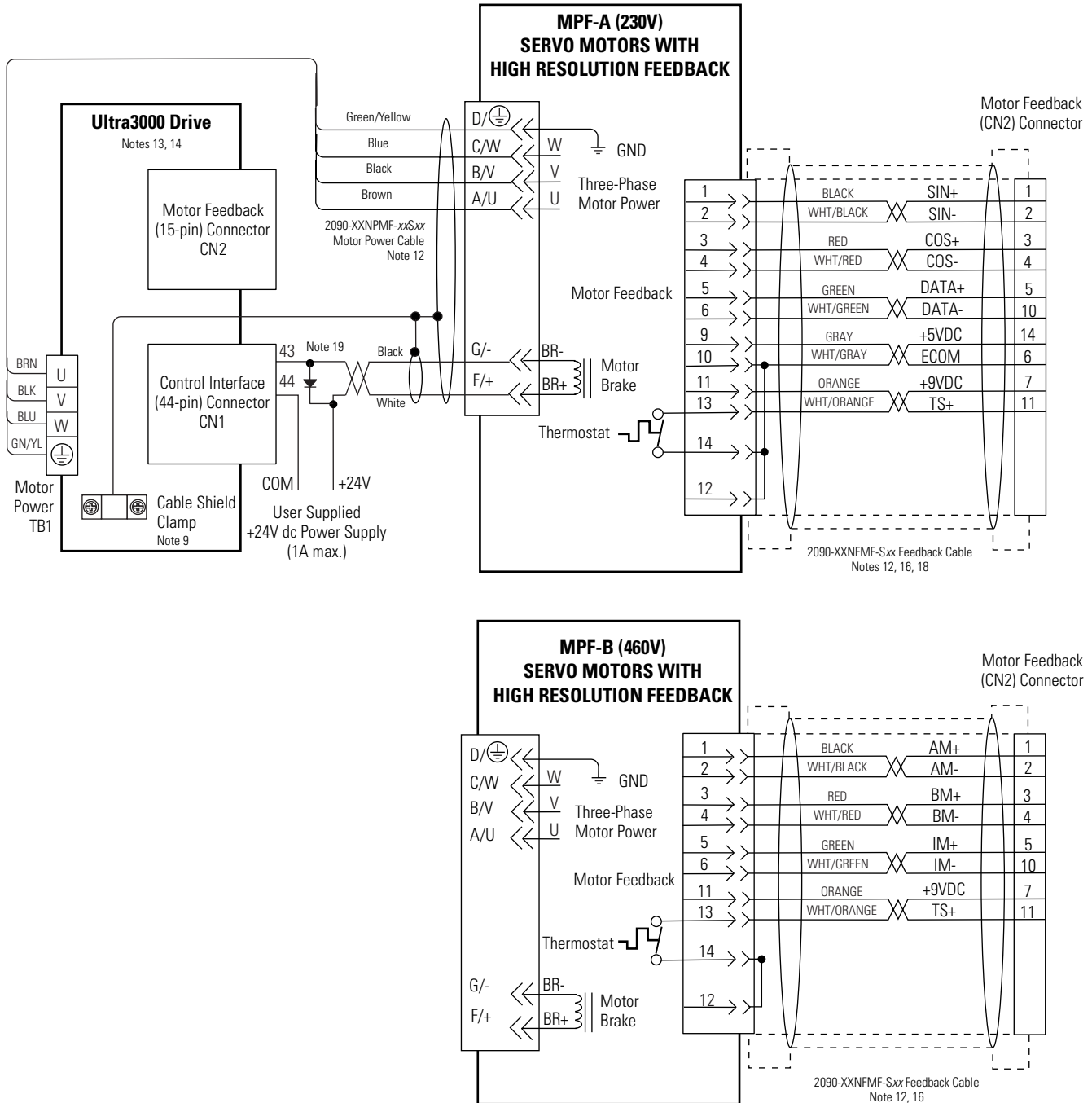

IMPORTANT

MPF-A5xxx motors are not compatible with Ultra3000 (2098-DSD-005, -010, -020) drives.

In the figure below, the Ultra3000 (230V) is shown connected to H- and F-Series (230V) servo motors.

Figure B.13
Ultra3000 to H- and F-Series (230V) Motor Configuration

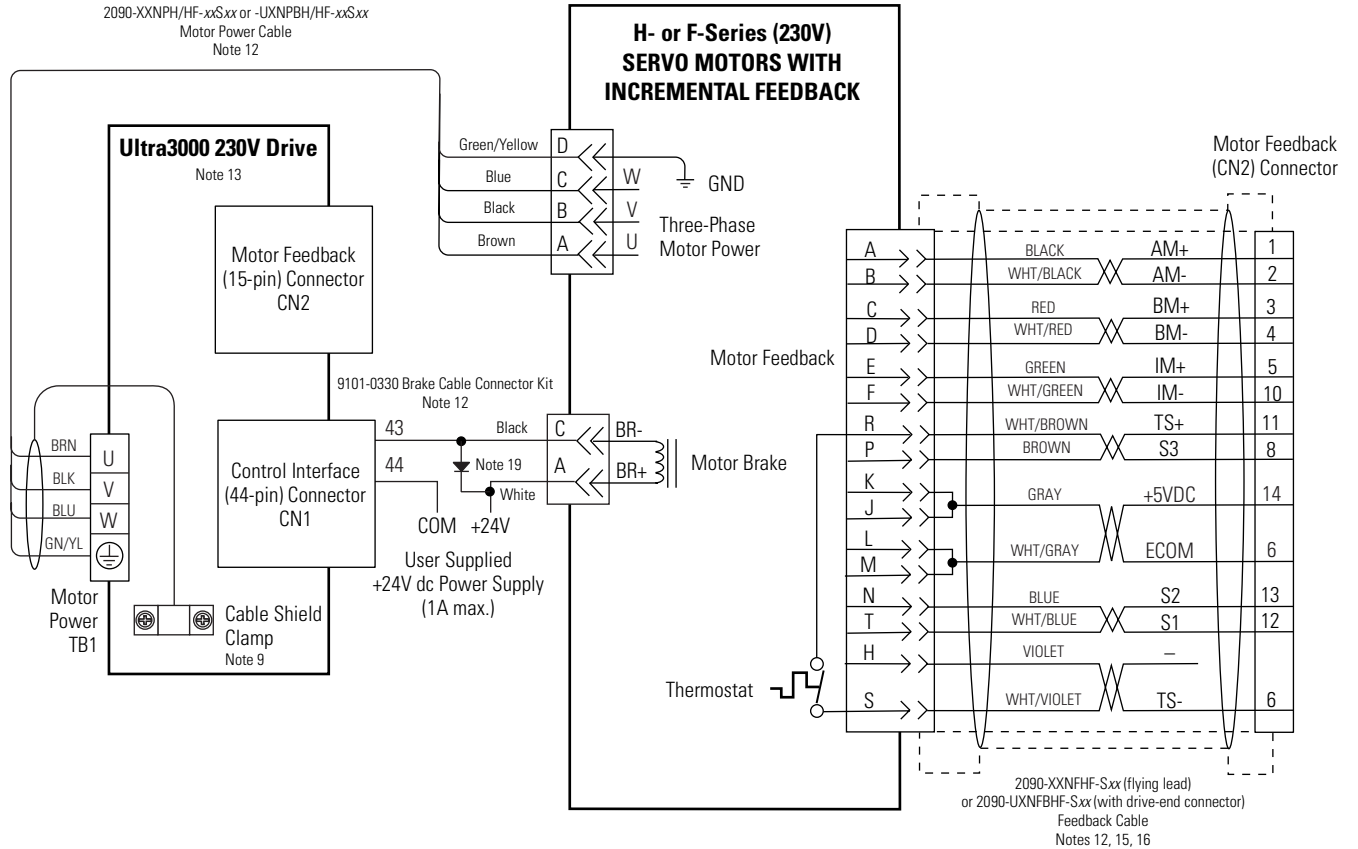

In the figure below, the Ultra3000 (230V) is shown connected to N-Series (230V) servo motors.

Figure B.14
Ultra3000 to N-Series (230V) Motor Configuration

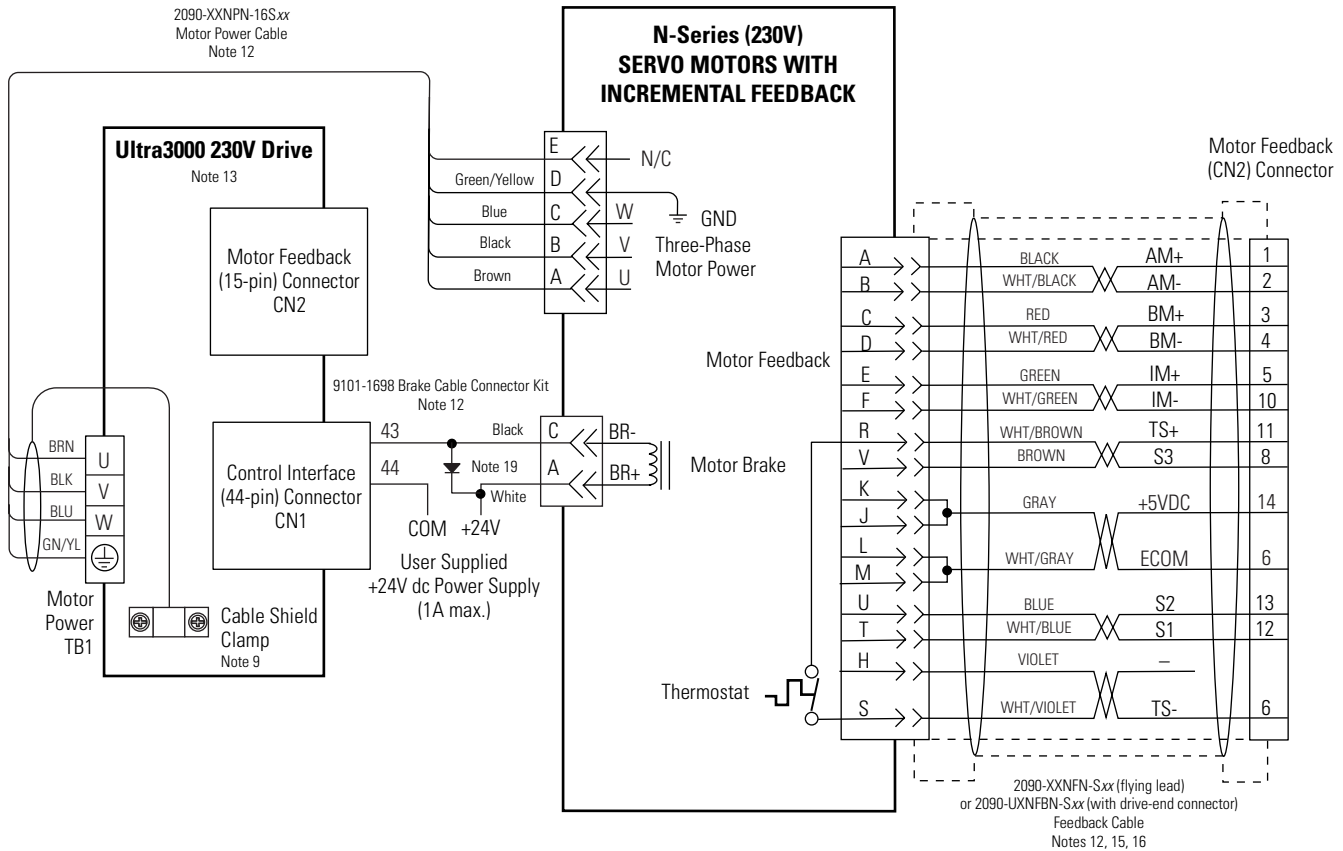

In the figure below, the Ultra3000 (230V) is shown connected to Y-Series (230V) servo motors.

Figure B.15
Ultra3000 to Y-Series (230V) Motor Configuration

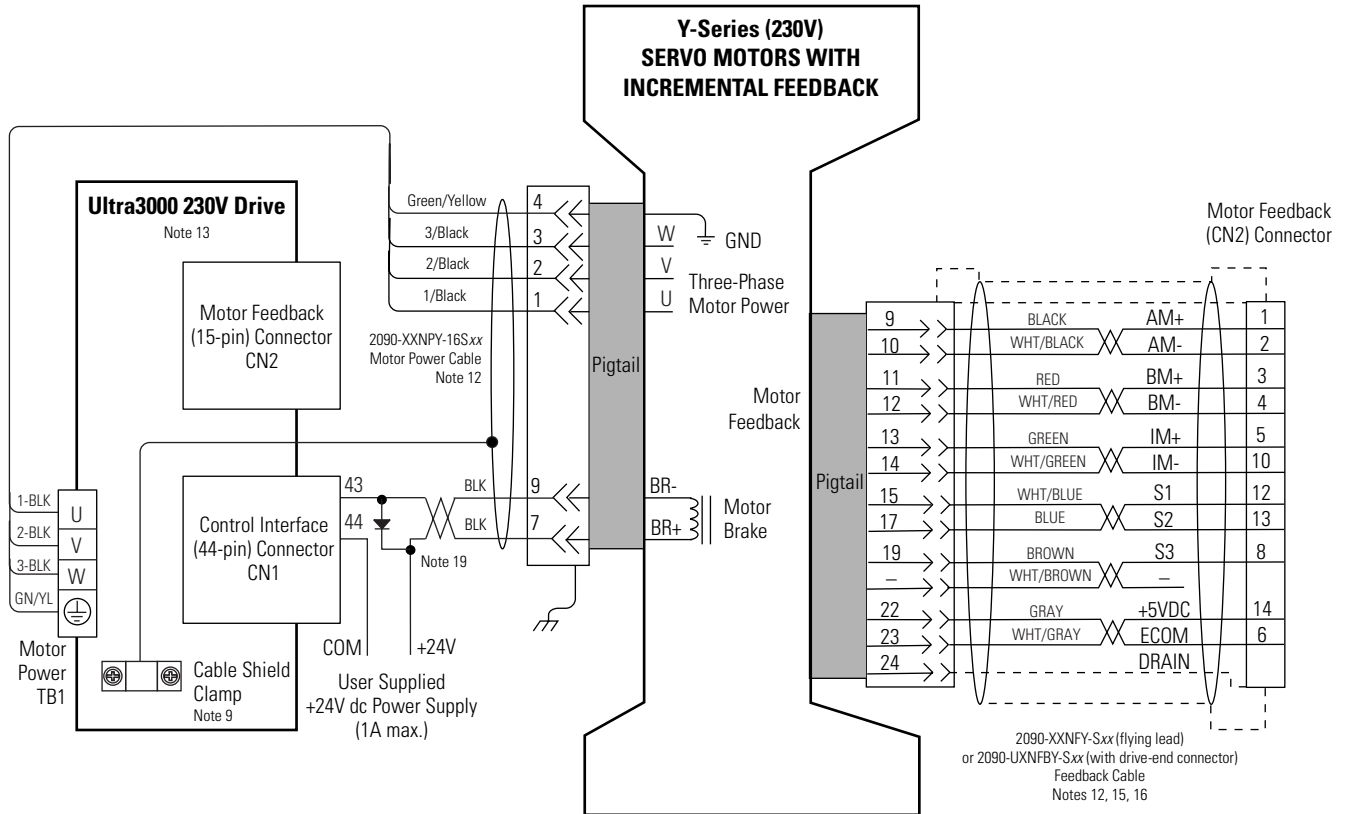

Control String Examples (120V ac)

This section provides information to assist you in using the configurable Drive Ready output in a control string with 120V ac input voltage. Refer to Figure 2.26 in the chapter *Ultra3000 Connector Data* for more information on the digital relay output.

The 120V ac control string wired to the Ultra3000 (2098-DSD-005x-xx, -010x-xx, or -020x-xx) drives is shown in the figure below.

ATTENTION



Implementation of safety circuits and risk assessment is the responsibility of the machine builder. Please reference international standards EN1050 and EN954 estimation and safety performance categories. For more information refer to *Understanding the Machinery Directive* (publication SHB-900).

Figure B.16
120V ac Single-Phase Control String Example

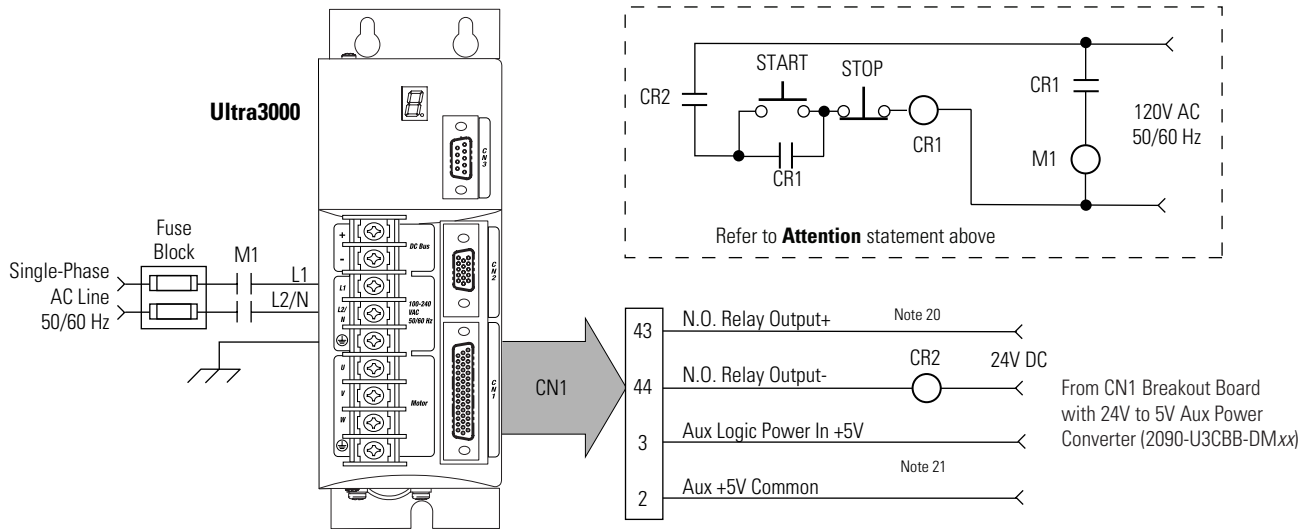

The 120V ac control string wired to the Ultra3000 (2098-DSD-030x-xx) drives is shown in the figure below.



ATTENTION Implementation of safety circuits and risk assessment is the responsibility of the machine builder. Please reference international standards EN1050 and EN954 estimation and safety performance categories. For more information refer to *Understanding the Machinery Directive* (publication SHB-900).

Figure B.17
120V ac Single-Phase Control String Example

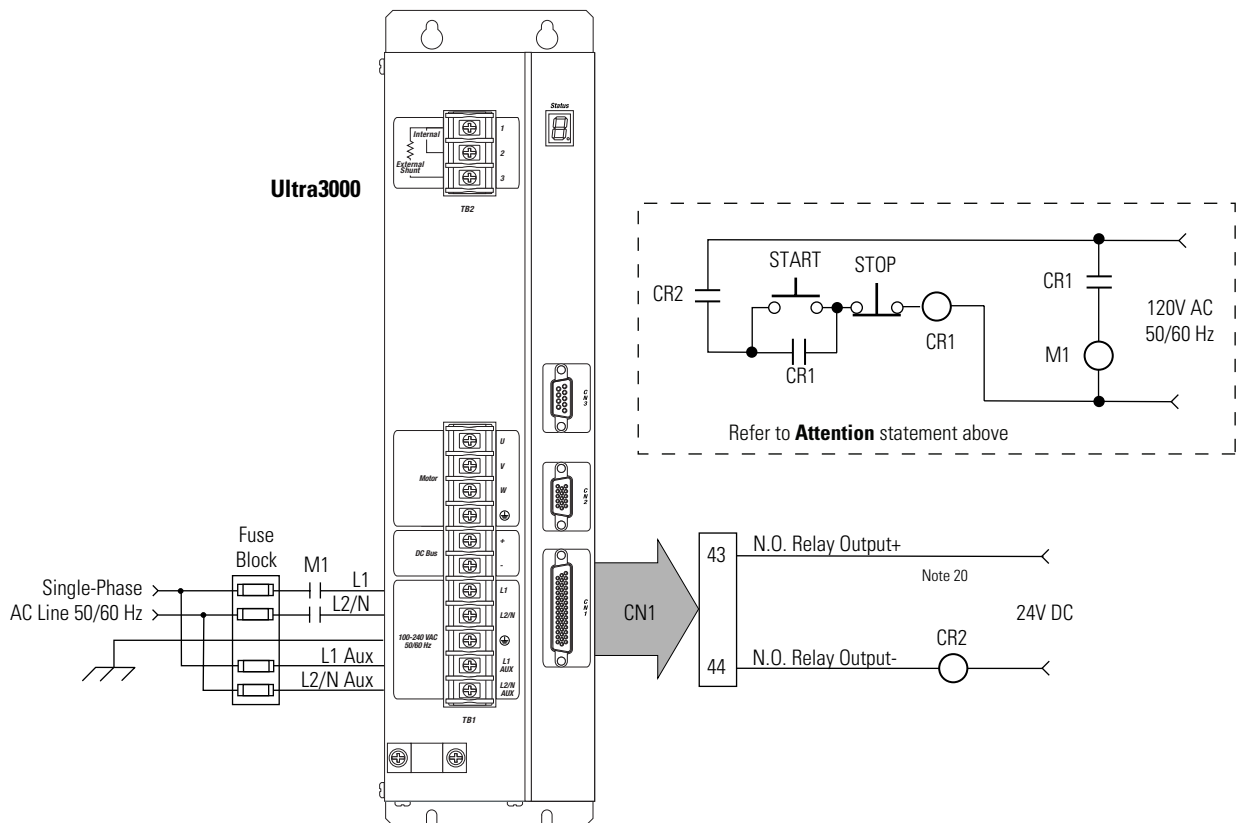

The 120V ac control string wired to the Ultra3000 (2098-DSD-075x-xx, -150x-xx, -HVxxx-xx, and -HVxxxX-xx) drives is shown in the figure below.

ATTENTION



Implementation of safety circuits and risk assessment is the responsibility of the machine builder. Please reference international standards EN1050 and EN954 estimation and safety performance categories. For more information refer to *Understanding the Machinery Directive* (publication SHB-900).

Figure B.18
120V ac Three-Phase Control String Example

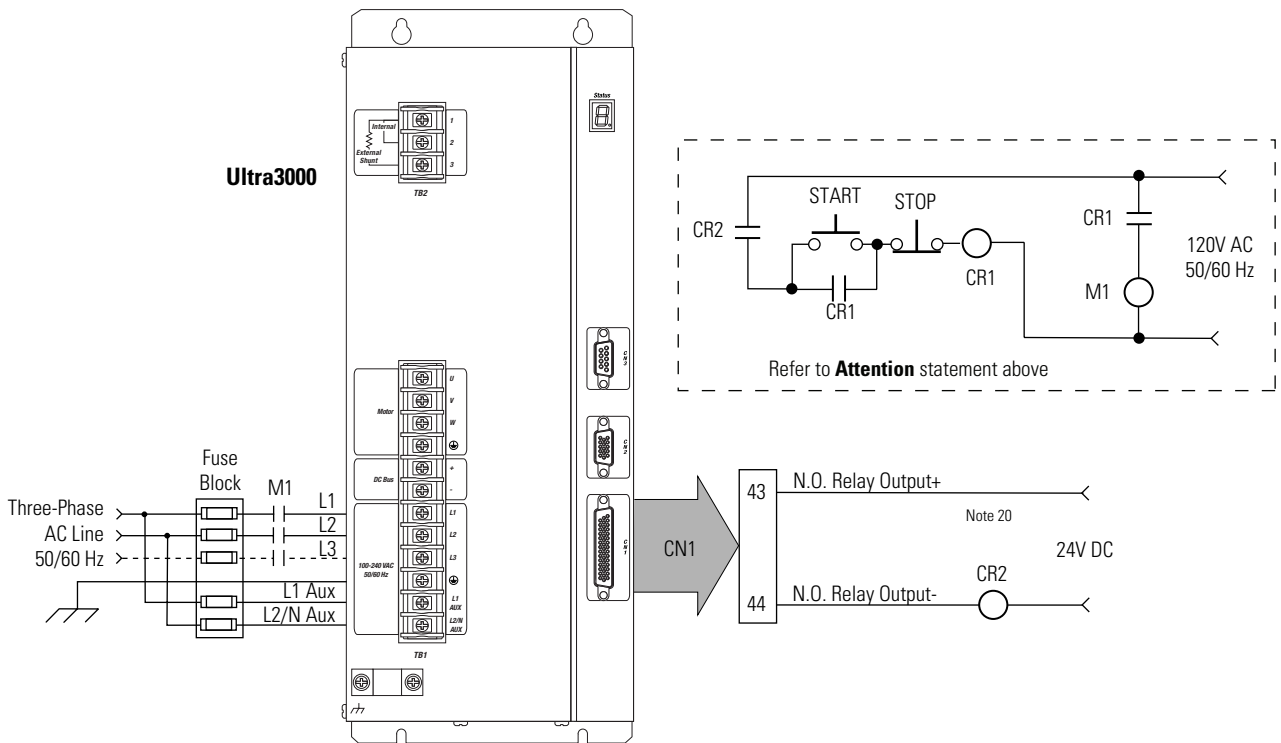

Controlling a Brake Example

The relay output of the Ultra3000 is suitable for directly controlling a motor brake, subject to the relay voltage limit of 30V dc, and the relay current limit of 1A dc. For brake requirements outside of these limits, an external relay must be used. If a transistor output is used, a control relay is also required.

The following table lists Allen-Bradley motors that are compatible with the internal relay output (CN1, pins 43 and 44), when used for controlling a brake. All other motors require an external control relay.

Compatible Brake Motors	Brake Current
F-4030, -4050, and -4075	0.88A
H-3007 and -3016	0.60A
H-4030, -4050, and -4075	0.69A
N-2302, and -2304	0.28A
N-3406, -3412, -4214, and -4220	0.36A
N-5630, -5637, and -5647	0.71A
Y-1002 and -1003	0.26A
Y-2006 and -2012	0.31A
Y-3023	0.37A

Compatible Brake Motors	Brake Current
MPL/MPF-x310, -x320, -x330 ¹	0.50A
MPL-x420, -x430, -x4520, -x4530, -x4540 ¹	0.64A
MPF-x430, -x4530, -x4540 ¹	
MPG-x004 ¹	0.33A
MPG-x010 ¹	0.45A
MPG-x025 ¹	
MPG-x050 ¹	0.50A
MPG-x110 ¹	1.0A
1326AB-B4xxx	0.88A

¹ Applies to 230V and 460V motors.

Figure B.19 shows an example configuration using Digital Output 1 and an external control relay to control a motor brake which exceeds internal relay ratings.

Figure B.19
Example Configuration Controlling a Motor Brake

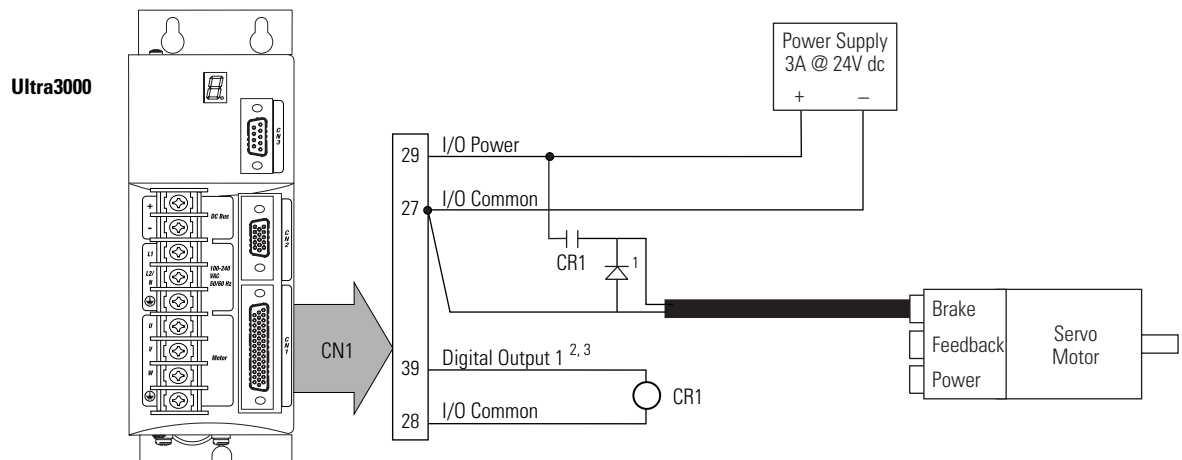

¹ Flyback diode (1N4004 rated 1.0A @ 400V dc) suppresses collapsing field of brake coil.

² Digital Output 1 (pin 39) configured as Brake in Ultraware software.

³ For Digital Output 1 specifications, refer to Figure 2.25 in *Chapter 2*.

IMPORTANT

Flyback diodes must be used when controlling a brake coil with the relay or digital output.

Ultra3000 to Logix Cable and Interconnect Diagrams

This section provides information to assist you in wiring the Ultra3000 CN1 (44-pin) cable connector with either the ControlLogix 1756-M02AE servo module or SoftLogix™ 1784-PM02AE motion card.

Use the 2090-U3AE-D44xx control interface cable (shown below) when connecting two Ultra3000 drives to the 1756-M02AE servo module. This cable includes the 1756-TBCH pre-wired terminal block. Refer to Figure B.22 for the interconnect diagram.

Figure B.20
2090-U3AE-D44xx Two Axis Cable

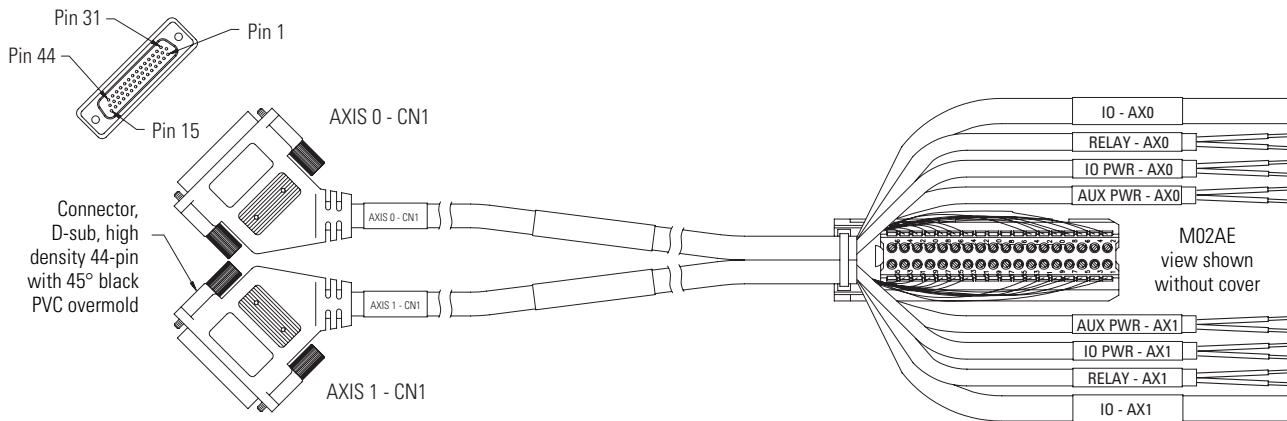

Use the 2090-U3CC-D44xx control interface cable (shown below) when connecting a single Ultra3000 drive to either the 1756-M02AE (ControlLogix) servo module or 1784-PM02AE (SoftLogix) PCI card. The 1756-TBCH removable terminal block is required when wiring to the ControlLogix module. The 1784-PM02AE-TPxx termination panel is required when wiring to the SoftLogix PCI Card. Refer to Figure B.23 for the interconnect diagram.

Figure B.21
Control Interface Cable and Terminations

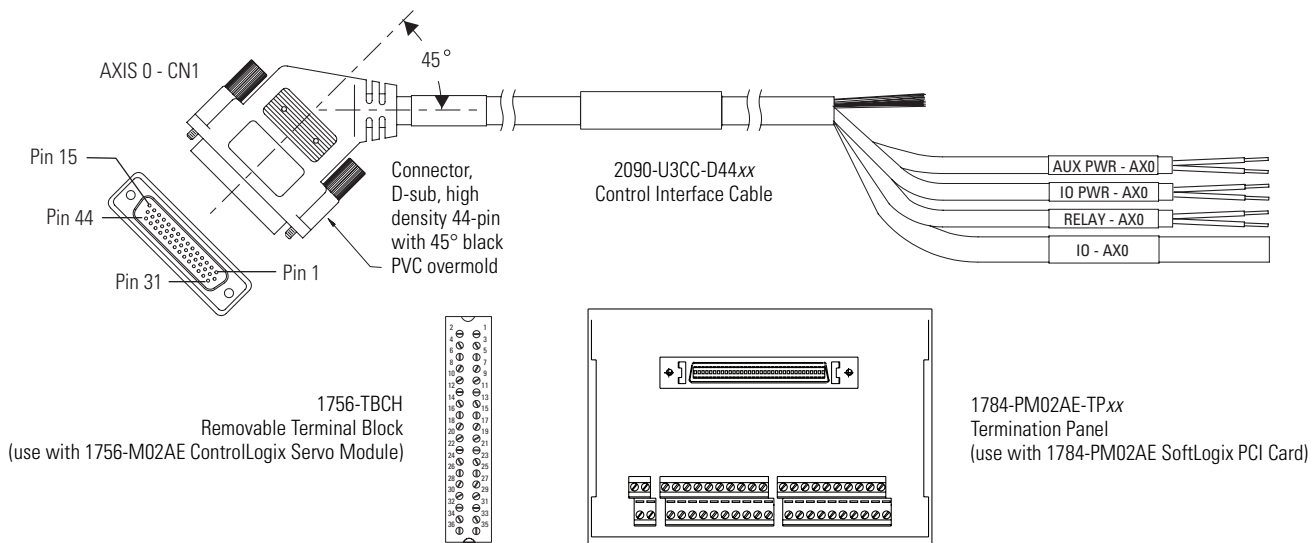
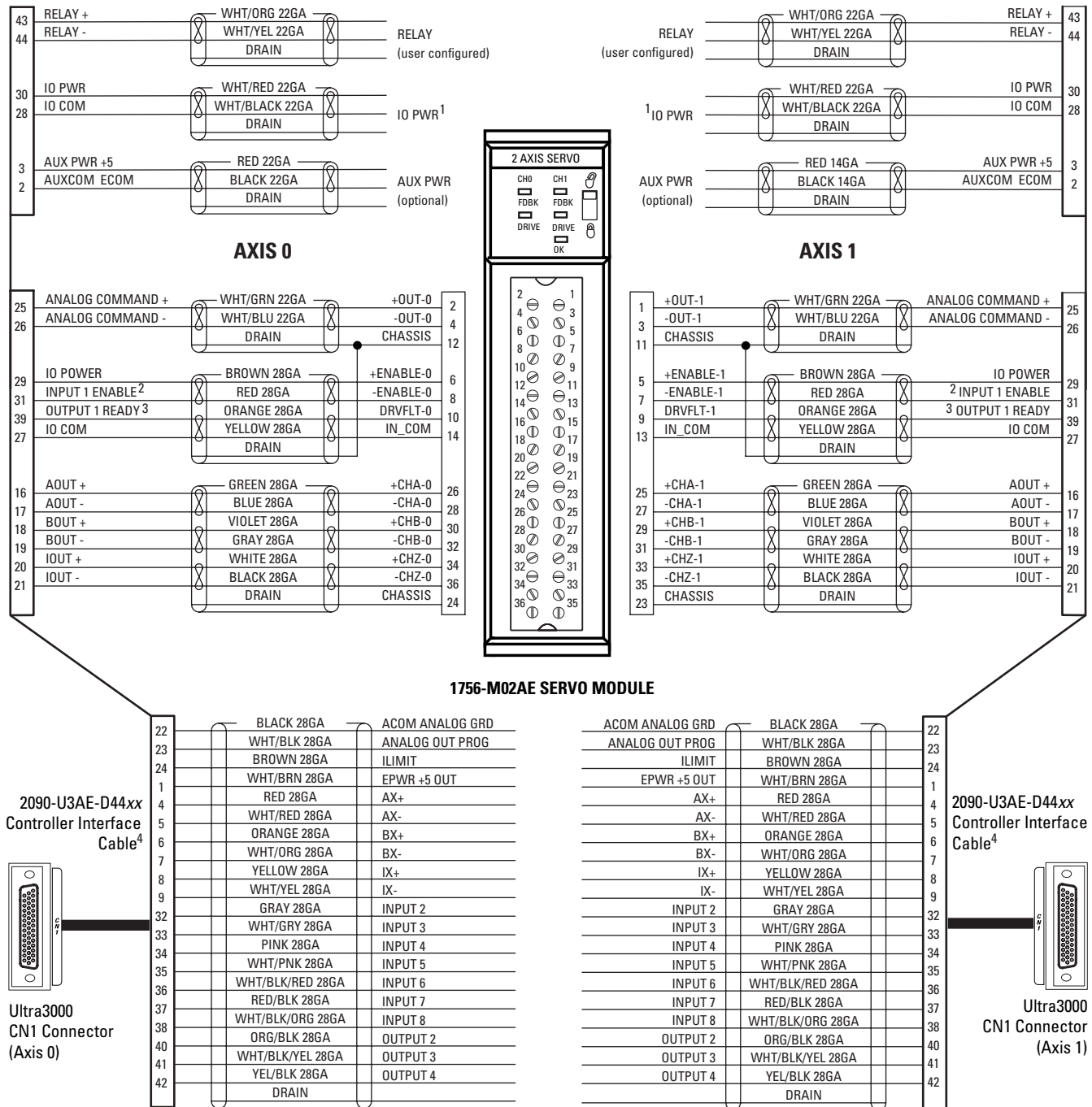
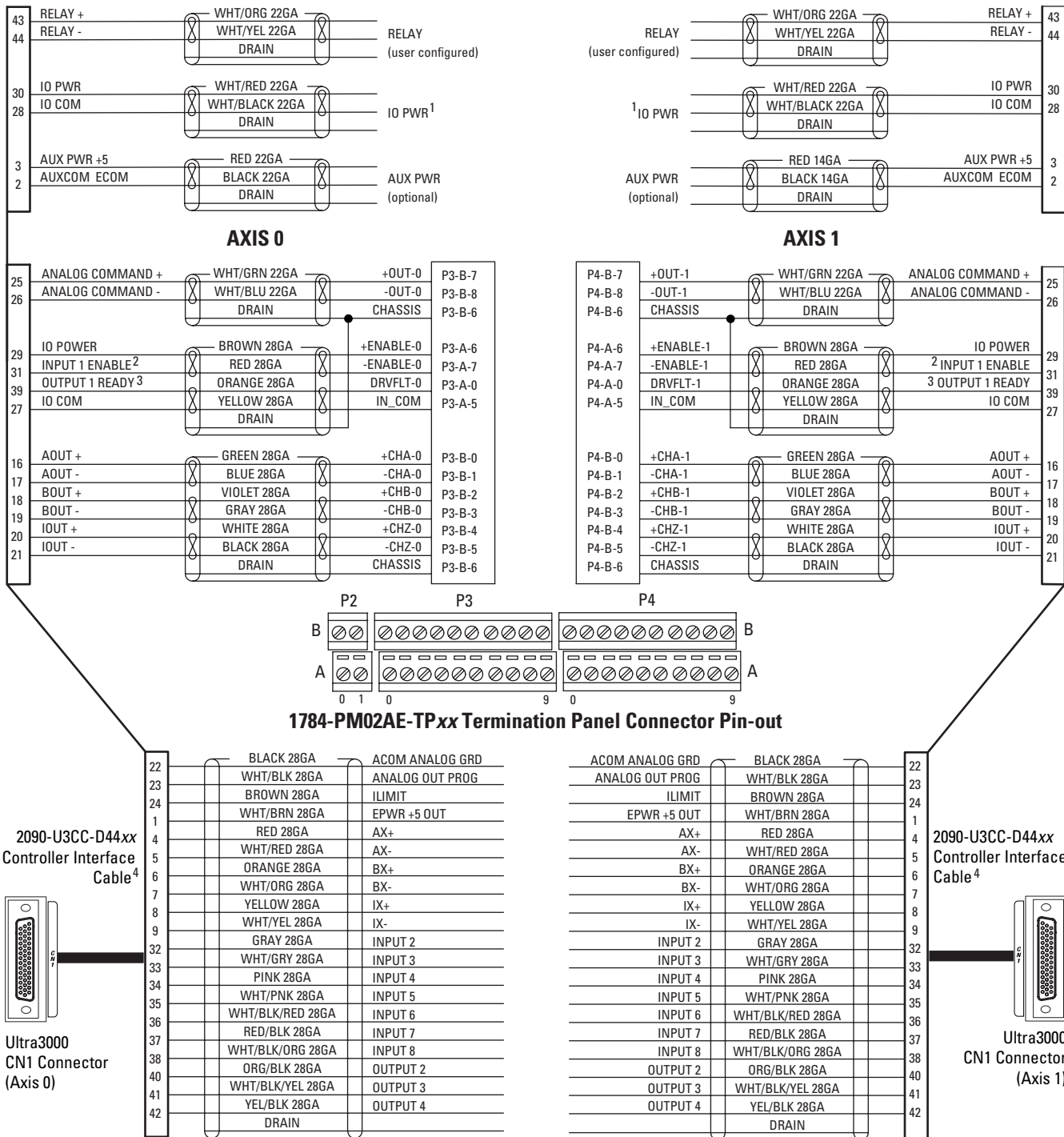

Figure B.22
Ultra3000 to ControlLogix Servo Module Interconnect Diagram



¹ I/O power (pins 28 and 30) must be connected to user-supplied 12-24V dc.
² Input 1 (pin 31) must be configured as Drive Enable using Ultraware software.
³ Output 1 (pin 39) must be configured as Ready using Ultraware software.
⁴ This cable does not carry the unbuffered motor encoder signals (CN1 pins 10-15). Contact your Allen-Bradley sales representative if these signals are required for your application.

Figure B.23
Ultra3000 to SoftLogix PCI Card Interconnect Diagram



¹ I/O power (pins 28 and 30) must be connected to user-supplied 12-24V dc.
² Input 1 (pin 31) must be configured as Drive Enable using Ultraware software.
³ Output 1 (pin 39) must be configured as Ready using Ultraware software.
⁴ This cable does not carry the unbuffered motor encoder signals (CN1 pins 10-15). Contact your Allen-Bradley sales representative if these signals are required for your application.

Ultra3000 to IMC-S Compact Cable and Interconnect Diagram

This section provides information to assist you in wiring the IMC-S/23x-xx Compact Controller when connecting the 4100-CCS15F feedback cable and 4100-CCA15F I/O cable to your Ultra3000.

Figure B.24
Ultra3000 to IMC-S/23x-xx Compact Controller Configuration

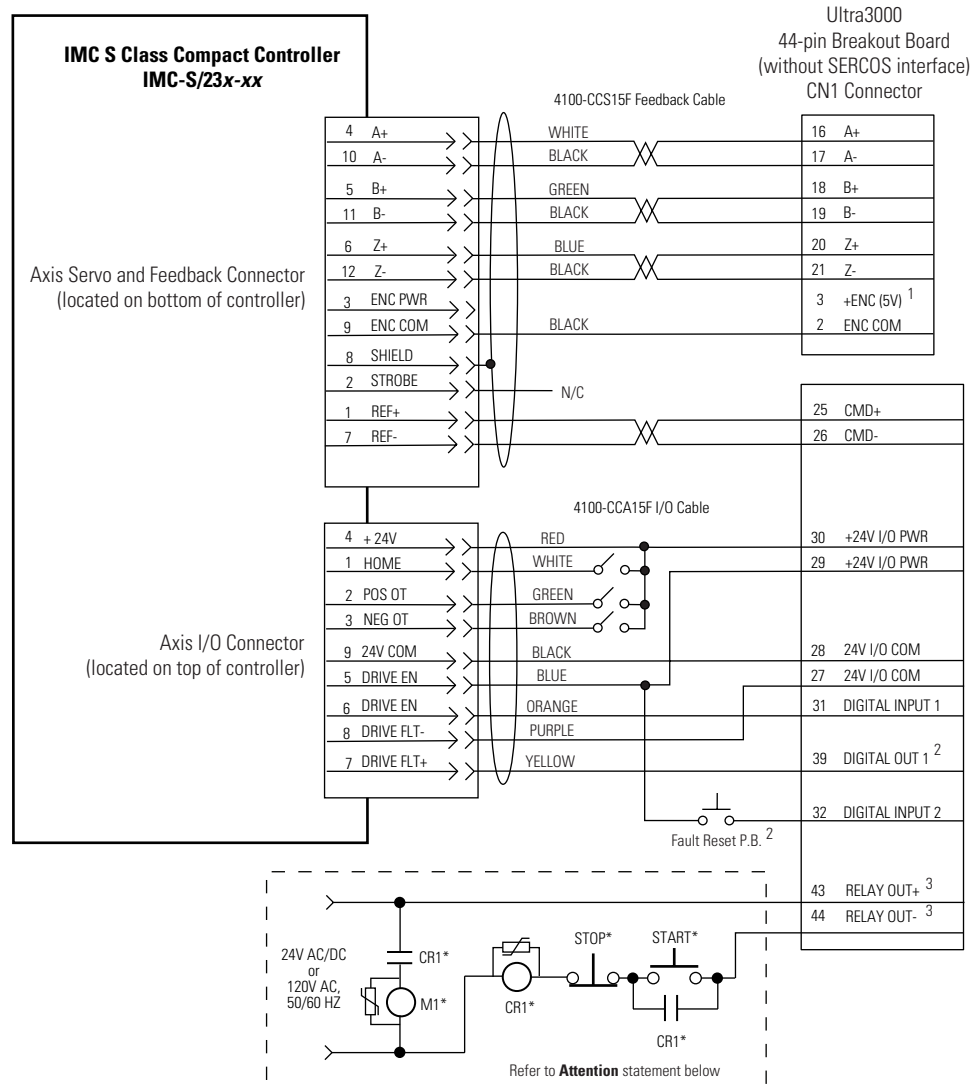

¹ The preferred method for supplying the auxiliary +5V is by using the 12- or 44-pin drive mounted breakout board with 24V to 5V auxiliary power converter (catalog number 2090-U3CBB-DM12 or -DM44). Auxiliary +5V power is required to maintain encoder position with an external position controller during a controlled stop condition.

² Drive Enable and Fault Reset are configured in Ultraware software.

³ Relay Output (CN1, pins 43 and 44) must be configured as Ready in Ultraware software.

ATTENTION



Implementation of safety circuits and risk assessment is the responsibility of the machine builder. Please reference international standards EN1050 and EN954 estimation and safety performance categories. For more information refer to *Understanding the Machinery Directive* (publication SHB-900).

Catalog Numbers and Accessories

Chapter Objectives

This appendix lists the Ultra3000 drives and accessory items in tables by catalog number providing detailed descriptions of each component. This appendix describes catalog numbers for:

- Ultra3000 Drives
- Software
- AC Line Filters
- External Shunt Kits
- Motor Power Cables
- Motor Feedback Cables
- MP-Series Motor Brake Cable
- Ultra3000 Interface Cables
- SERCOS Interface Fiber-Optic Cables
- Drive End Connector Kits
- Motor End Connector Kits
- Breakout Boards, Cables, and Kits

Contact your local Allen-Bradley sales office for additional information. Refer to the *Motion Control Selection Guide* (publication GMC-SG001.x-EN-P) for details on products.

Ultra3000 Drives

Use the following table to identify Ultra3000 240V drives with ratings of 500W, 1 kW, and 2 kW where -xxx equals 005, 010, or 020.

Description	Catalog Number
Ultra3000 Digital Servo Drive	2098-DSD-xxx
Ultra3000i Digital Servo Drive (with Indexing)	2098-DSD-xxxX
Ultra3000 Digital Servo Drive (with SERCOS)	2098-DSD-xxx-SE
Ultra3000 Digital Servo Drive (with DeviceNet)	2098-DSD-xxx-DN
Ultra3000 Digital Servo Drive (with DeviceNet and Indexing)	2098-DSD-xxxX-DN

Use the following table to identify Ultra3000 240V drives with ratings of 3 kW, 7.5 kW, and 15 kW where -xxx equals 030, 075, or 150.

Description	Catalog Number
Ultra3000 Digital Servo Drive	2098-DSD-xxx
Ultra3000i Digital Servo Drive (with Indexing)	2098-DSD-xxxX
Ultra3000 Digital Servo Drive (with SERCOS)	2098-DSD-xxx-SE
Ultra3000 Digital Servo Drive (with DeviceNet)	2098-DSD-xxx-DN
Ultra3000 Digital Servo Drive (with DeviceNet and Indexing)	2098-DSD-xxxX-DN

Use the following table to identify Ultra3000 460V drives with ratings of 3 kW, 5 kW, 10 kW, 15 kW, and 22 kW where -xxx equals 030, 050, 100, 150, or 220.

Description	Catalog Number
Ultra3000 Digital Servo Drive	2098-DSD-HVxxx
Ultra3000i Digital Servo Drive (with Indexing)	2098-DSD-HVxxxX
Ultra3000 Digital Servo Drive (with SERCOS)	2098-DSD-HVxxx-SE
Ultra3000 Digital Servo Drive (with DeviceNet)	2098-DSD-HVxxx-DN
Ultra3000 Digital Servo Drive (with DeviceNet and Indexing)	2098-DSD-HVxxxX-DN

Software

The Ultra3000-SE drives are configured using RSLogix 5000. Ultra3000, Ultra3000 with indexing, Ultra3000-DN, and Ultra3000-DN with indexing drives are configured using Ultraware.

Both are Windows® based applications that allow drive configuration to be done off-line and saved to disk.

Description	Catalog Number
RSLogix 5000 Software (version 11.0 or above)	9324-RLD300ENE
Ultraware Software	2098-UWCPRG

AC Line Filters

Use the following table to identify the AC Line Filter for your application.

AC Line Filter Description	AC Line Filter Fuse Block	Catalog Number
AC Line Filter (single-phase, 240V)	6 Amp	2090-UXLF-106
	10 Amp	2090-UXLF-110
	23 Amp	2090-UXLF-123
	32 Amp	2090-UXLF-132
	36 Amp	2090-UXLF-136
	50 Amp	2090-UXLF-150
AC Line Filter (three-phase, 240V)	36 Amp	2090-UXLF-336
	50 Amp	2090-UXLF-350
	70 Amp	2090-UXLF-370
AC Line Filter (three-phase, 480V)	23 Amp	2090-UXLF-HV323
	30 Amp	2090-UXLF-HV330
	50 Amp	2090-UXLF-HV350

External Shunt Kits

Use the following table to identify the external shunt kit for your application.

Shunt Module Catalog Number:	Description:	Ultra3000 Drive Compatibility:
2090-UCSR-A300	Active Shunt Module (300W)	2098-DSD-005, -010, -020
9101-1183	Passive Shunt Module (200W)	2098-DSD-030
2090-UCSR-P900	Passive Shunt Module (900W)	2098-DSD-075, -150
2090-SR120-09		2098-DSD-HV030 and -HV050
2090-SR040-09		2098-DSD-HV100
2090-SR040-18		
M3575R-H27B0,C ¹	Passive Shunt Module (900W)	2098-DSD-HV150
M3575R-H27BF,C ¹	Passive Shunt Module (1800W)	
M3575R-H33BF,C ¹	Passive Shunt Module (3600W)	2098-DSD-HV220

¹ Bonitron part number. For more information contact Bonitron, Inc. 521 Fairground Court, Nashville, TN 37211. Tel: (615) 244-2825. www.BONITRON.com.

Cables

Use the following tables to identify motor power, feedback, interface, and brake cables for your Ultra3000 drive. Length of cable *xx* is in meters. Refer to your Allen-Bradley representative for available cable lengths.

Motor Power Cables

Description	Catalog Number
H-Series, 230V, non-flex, 16 AWG, straight	2090-XXNPH-16S xx
H-Series, 230V, non-flex, 16 AWG, right angle	2090-UXNPAH-16R xx
H-Series, 230V, non-flex, 6 AWG, straight	2090-UXNPAH-6S xx
H-Series, 230V, non-flex, 6 AWG, right angle	2090-UXNPAH-6R xx
H and F-Series, 230V, non-flex, 14 AWG, straight	2090-XXNPHF-14S xx
H and F-Series, 230V, non-flex, 14 AWG, right angle	2090-UXNPAHF-14R xx
H and F-Series, 230V, non-flex, 10 AWG, straight	2090-UXNPAHF-10S xx
H and F-Series, 230V, non-flex, 10 AWG, right angle	2090-UXNPAHF-10R xx
H and F-Series, 230V, non-flex, 8 AWG, straight	2090-UXNPAHF-8S xx
H and F-Series, 230V, non-flex, 8 AWG, right angle	2090-UXNPAHF-8R xx
MP-Series (MPL/MPG), 230/460V, non-flex, 16 AWG, straight	2090-XXNPMP-16S xx
1326AB (M2L/S2L), 460V, non-flex, 16 AWG, straight	
MP-Series (MPL/MPG), 230/460V, non-flex, 14 AWG, straight	2090-XXNPMP-14S xx
MP-Series (MPL/MPG), 230/460V, non-flex, 10 AWG, straight	2090-XXNPMP-10S xx
1326AB (M2L/S2L), 460V, non-flex, 10 AWG, straight	
MP-Series (MPL/MPG), 230/460V, non-flex, 8 AWG, straight	2090-XXNPMP-8S xx
MP-Series (MPF), 230/460V, non-flex, 16 AWG, straight	2090-XXNPMF-16S xx
MP-Series (MPF), 230/460V, non-flex, 14 AWG, straight	2090-XXNPMF-14S xx
MP-Series (MPF), 230/460V, non-flex, 10 AWG, straight	2090-XXNPMF-10S xx
N-Series, 230V, non-flex, 16 AWG, straight	2090-XXNPN-16S xx
N-Series, 230V, non-flex, 16 AWG, right angle	2090-UXNPAN-16R xx
Y-Series, 230V, non-flex, 16 AWG, straight	2090-XXNPY-16S xx

Motor Feedback Cables

Description	Catalog Number
H-Series, non-flex, connector at both ends, right angle	2090-UXNFBH-Rxx
H-Series, non-flex, motor connector to flying leads, right angle	2090-UXNFDH-Rxx
H and F-Series, non-flex, connector at both ends, straight	2090-UXNFBHF-Sxx
H and F-Series, non-flex, motor connector to flying leads, straight	2090-XXNFHF-Sxx
H and F-Series, non-flex, connector at both ends, right angle	2090-UXNFBHF-Rxx
H and F-Series, non-flex, connector at both ends, right angle, skewed	2090-UXNFBHF-Kxx
MP-Series (MPL/MPG), non-flex, connector at both ends, straight	2090-UXNFBMP-Sxx
1326AB-Series (M2L/S2L), non-flex, connector at both ends, straight	
MP-Series (MPL/MPG), non-flex, motor connector to flying leads, straight	2090-XXNFMP-Sxx
1326AB-Series (M2L/S2L), non-flex, motor connector to flying leads, straight	
MP-Series (MPF), non-flex, motor connector to flying leads, straight	2090-XXNFMF-Sxx
N-Series, non-flex, connector at both ends, straight	2090-UXNFBN-Sxx
N-Series, non-flex, motor feedback connector to flying leads, straight	2090-XXNFN-Sxx
N-Series, non-flex, connector at both ends, right angle	2090-UXNFBN-Rxx
N-Series, non-flex, connector at both ends, right angle, skewed	2090-UXNFBN-Kxx
N-Series, non-flex, connector at both ends, right angle, skewed	2090-UXNFBN23-Kxx
N-Series, non-flex, motor connector to flying leads, right angle, skewed	2090-UXNFDN23-Kxx
N-Series, non-flex, motor connector to flying leads, right angle	2090-UXNFDN-Rxx
Y-Series, non-flex, connector at both ends, straight	2090-UXNFBY-Sxx
Y-Series, non-flex, motor feedback connector to flying leads, straight	2090-XXNFY-Sxx
Drive Feedback Cable, non-flex, CN2 connector to flying leads	2090-UXNFM-Sxx

MP-Series Motor Brake Cable

Description	Catalog Number
MP-Series motor brake cable, 0.75 mm ² (18 AWG)	2090-UXNBMP-18Sxx

Ultra3000 Interface Cables

Description	Catalog Number
Serial Interface Cable, 9-pin D-shell, CN3 to personal computer.	2090-UXPC-D09xx
Controller Interface Cable, 44-pin D-shell, CN1 to 1756-M02AE motion module (two-axis to premolded connector).	2090-U3AE-D44xx
Controller Interface Cable, 44-pin D-shell, CN1 to 1756-M02AE motion module (single-axis to no connector).	2090-U3CC-D44xx

SERCOS Interface Fiber-Optic Cables

Use the following table to identify the SERCOS interface fiber-optic plastic cables for your Ultra3000 (connectors at both ends).

Description	Catalog Number
SERCOS fiber-optic plastic cable (for use inside enclosure only)	2090-SCEP $x-x$
SERCOS fiber-optic plastic (PVC) cable (for use outside enclosure)	2090-SCVP $x-x$
SERCOS fiber-optic plastic (nylon) cable (for use outside enclosure in harsh environments)	2090-SCNP $x-x$
SERCOS fiber-optic glass (PVC) cable	2090-SCVG $x-x$

Note: Cable length ($x-x$) is in meters. Plastic cable is available in lengths up to 32 m (105.0 ft). Glass cable is available in lengths up to 200 m (656.7 ft).

Drive End Connector Kits

Use the following table to identify the drive-end connector kit for your serial, feedback, and I/O cable. Refer to the chapter *Ultra3000 Connector Data* for pin signal, and wiring information.

Description	Catalog Number
Drive Connector Kit, 9-pin D-shell, serial cable to drive (CN3)	2090-UXCK-D09
Drive Connector Kit, 15-pin high density D-shell, feedback cable to drive (CN2)	2090-UXCK-D15
Drive Connector Kit, 44-pin high density D-shell, I/O cable to drive (CN1)	2090-U3CK-D44

The following table lists Amp drive cable connectors that are not available from Rockwell Automation. Please contact Amp at 1-800-522-6752 or a distributor for additional information.

Connector Components	CN1 Controller 44-Pin High-Density D-Shell	CN2 Motor Feedback 15-Pin High-Density D-Shell	CN3 Serial 9-Pin Standard-Density D-Shell
Drive Connector	748366-1	748364-1	205204-4
Crimp Pin Contacts	748333-4 ¹	748333-4 ¹	5-66506-7 ²
Unshielded Backshell Kit	748678-3	748678-1	748678-1
Shielded Backshell Kit	745173-3	745171-5	745171-5
Ferrules ³	745508-1	745508-6	745508-6

¹ Accepts 22-28 AWG wire.

² Accepts 20-24 AWG wire.

³ Ferrules are only required for use with shielded backshell kits.

Motor End Connector Kits

Use the following table to identify the motor-end connector kit for your motor power, feedback, and brake cable.

Motor Series	Motor Connector Kit	Description
F-4000	9101-0326	Straight Power Connector Kit
	9101-0399	Right-Angle Power Connector Kit
F-6000	9101-0327	Straight Power Connector Kit
	9101-0400	Right-Angle Power Connector Kit
F-Series	9101-0329	Straight Feedback Connector Kit
	9101-0330	Straight Brake Connector Kit
	9101-0402	Right-Angle Feedback Connector Kit
	9101-0403	Right-Angle Brake Connector Kit
H-2000	9101-0325	Straight Power Connector Kit
	9101-0398	Right-Angle Power Connector Kit
H-3000	9101-0325	Straight Power Connector Kit
	9101-0398	Right-Angle Power Connector Kit
H-4000	9101-0326	Straight Power Connector Kit
	9101-0399	Right-Angle Power Connector Kit
H-6000	9101-0327	Straight Power Connector Kit
	9101-0400	Right-Angle Power Connector Kit
H-8000	9101-0328	Straight Power Connector Kit
	9101-0401	Right-Angle Power Connector Kit
H-Series	9101-0329	Straight Feedback Connector Kit
	9101-0330	Straight Brake Connector Kit
	9101-0402	Right-Angle Feedback Connector Kit
	9101-0403	Right-Angle Brake Connector Kit
MP-Series and 1326AB (M2L/S2L)	2090-MPPC-S	Straight Power Connector Kit
	2090-MPPC-08S	Straight Power Connector Kit, 10 mm ² (8 AWG)
	2090-MPFC-S	Straight Feedback Connector Kit
	2090-MPBC-S	Straight Brake Connector Kit
N-Series	9101-1557	Straight Power Connector Kit
	9101-1558	Straight Feedback Connector Kit
	9101-1698	Brake Connector Kit
Y-Series	9106-0066	Straight Power and Feedback Connector Kit

Breakout Board Kits

Breakout board kits include the 2090-UxBB-Dxx DIN rail terminal block, 2090-UxBC-Dxxxx cable, and mounting hardware.

Catalog Number	Description
2090-UXBK-D15xx	15-pin, high density D-shell for Ultra3000 CN2 interface connector
2090-U3BK-D44xx	44-pin, high density D-shell for Ultra3000 CN1 control interface connector

Breakout Boards

Catalog Number	Description
2090-U3BB-DM12 ¹	12-pin, drive-mounted breakout board for Ultra3000 CN1 connector recommended for use with SERCOS interface applications
2090-U3BB2-DM44 ^{1, 2}	44-pin, drive-mounted breakout board for Ultra3000 CN1 control interface connector
2090-U3CBB-DM12 ³	12-pin, drive-mounted breakout board for Ultra3000 CN1 connector recommended for use with SERCOS interface applications with 24V to 5V auxiliary power converter
2090-U3CBB-DM44 ³	44-pin, drive-mounted breakout board for Ultra3000 CN1 connector with 24V to 5V auxiliary power converter
2090-U3BB-D44	44-pin, high density D-shell for Ultra3000 CN1 control interface connector
2090-UXBB-DM15 ⁴	15-pin, drive-mounted breakout board for Ultra3000/5000 CN2 interface connector
2090-UXBB-D15	15-pin, high-density D-shell for Ultra3000/5000 CN2 interface connector
2090-UXBB-DM09	9-pin, drive-mounted breakout board for Ultra3000/5000 CN3 serial interface

¹ For specifications, refer to the *CN1 Control Interface Breakout Boards Installation Instructions* (publication 2090-IN007x-EN-P).

² This breakout board accepts 1 - 0.14 mm² (16 - 26 AWG) wire. For applications that require a 44-pin drive-mounted breakout board that accepts 4 - 0.5 mm² (12 - 22 AWG) wire, contact your local Allen-Bradley representative.

³ Only for use with the Ultra3000 (2098-DSD-005x-xx, -010x-xx, -020x-xx) drives. Requires an external +24V dc power supply (refer to *Auxiliary 5V Logic Supply* on page 2-26). For specifications, refer to the *CN1 Control Interface Breakout Boards with Integral 24V to 5V Auxiliary Power Converter Installation Instructions* (publication 2090-IN008x-EN-P).

⁴ For specifications, refer to the *CN2 Motor Feedback Breakout Board Installation Instructions* (publication 2090-IN006x-EN-P).

Breakout Cables

Catalog Number	Description
2090-UXBC-D15xx	15-pin, high-density D-shell for Ultra3000 CN2 interface connector
2090-U3BC-D44xx	44-pin, high density D-shell for Ultra3000 CN1 control interface connector

Numerics

- 16 axis SERCOS interface PCI card installation instructions P-3
- 1756-MxxSE interface module 3-26
- 1784-PM16SE PCI card 3-26
- 2090-U3AE-D44
 - cable B-20
 - interconnect diagram B-21
- 2090-U3CBB-DM12 2-27
- 2090-U3CBB-DM44 2-27
- 2090-U3CC-D44
 - cable B-20
 - interconnect diagram B-22
- 24V to 5V converter 2-26, C-8
- 3, 8, or 16 axis SERCOS interface module installation instructions P-3

A

- abbreviations P-4
- AC line filters C-3
 - noise reduction 1-15
 - specifications A-11
- AC power 3-13
- analog COMMAND input 2-37
- analog encoder PCI card
 - installation instructions P-3
- analog encoder servo module
 - installation instructions P-3
- analog ILIMIT input 2-38
- analog output 2-39
- auxiliary encoder feedback 2-49
- auxiliary feedback specifications A-10

B

- baud rate 2-51
- before mounting your system 1-5
- bonding
 - EMI (ElectroMagnetic Interference) 1-10
 - painted panels 1-11
 - subpanels 1-12
- brake B-19
- brake cables, MP-series C-5
- breakout boards with 24V to 5V converter 2-26, C-8

- breakout components
 - breakout board kits C-8
 - breakout boards C-8
 - breakout cables C-8
- building your own cables 3-2

C

- cable combinations 3-24
- cable shield clamp 3-18
- cables
 - 2090-U3AE-D44 B-20
 - 2090-U3CC-D44 B-20
 - building your own cables 3-2
 - categories 1-14
 - fiber optic cable length 3-26
 - fiber optic cables C-6
 - interface cables C-5
 - motor feedback cables C-5
 - motor power C-4
 - MP-series brake cables C-5
 - Ultra3000 to 1326AB motors B-10
 - Ultra3000 to H- and F-series motor B-13
 - Ultra3000 to IMC-S B-23
 - Ultra3000 to Logix B-20
 - Ultra3000 to MP-series motor B-10, B-11, B-12
 - Ultra3000 to N-series motor B-14
 - Ultra3000 to Y-series motor B-15
- catalog numbers
 - AC line filters C-3
 - drive end connector kits C-6
 - external shunt kit C-3
 - fiber optic cables C-6
 - interface cables C-5
 - motor feedback cables C-5
 - motor power cables C-4
 - MP-series brake cables C-5
 - RSLogix 5000 software C-2
 - Ultra3000 accessories C-1
 - Ultra3000 drives C-2
 - Ultraware software C-2
- CE
 - determining product compliance 1-2
 - invalidating compliance 3-8
 - Low Voltage Directive 1-3

- meeting requirements 1-2
- certifications A-1
 - Rockwell Automation Product Certification P-3
- circuit breaker specifications A-6
- clearances 1-7
- communications specifications A-9
- complying with CE 1-2
 - EMC directive 1-2
 - product compliance 1-2
- connecting
 - DeviceNet 3-29
 - external shunt resistor 3-22
 - feedback 3-23
 - fiber-optic cables 3-26
 - I/O 3-23
 - input power 3-16
 - motor brake 3-21
 - motor power 3-20
- connecting your Ultra3000 3-1
- connector
 - front panel connectors 2-1
- connector kits
 - drive end C-6
 - motor end C-7
- connector specifications A-10
- contactor specifications A-7
- contents of manual P-2
- control string
 - 120V single-phase, 0.5, 1, and 2 kW B-16
 - 120V single-phase, 3 kW B-17
 - 120V three-phase, 7.5 and 15 kW B-18
- control string examples B-16
- controlling a brake B-19
- ControlLogix integration P-1
- ControlLogix motion module programming manual P-3
- ControlLogix motion module setup and configuration manual P-3
- conventions used in this manual P-4

D

- data rate 3-29
- declarations of conformity (DOC) 1-2

- DeviceNet
 - cable 3-30
 - connector 3-30
 - network 3-29
- DeviceNet cable system planning and installation manual P-3, 3-29
- digital inputs 2-28
 - assigned preselect inputs 2-29
 - input interface examples 2-30, 2-32
- digital outputs
 - drive output examples 2-34
 - hardware configuration 2-33
- digital relay output B-2, B-16
- dimensions
 - 230V A-14, A-15
 - 460V A-16
- drive end connectors C-6
- drive ready B-16

E

- elevation requirements 1-6
- EMC
 - cable shield (bottom of drive) 3-11
 - cable shield (front of drive) 3-11
 - motor ground termination at motor 3-10
- EMI (ElectroMagnetic Interference)
 - HF bonding 1-10
- enclosure sizing A-7
- error codes and messages 4-3
- external shunt kit C-3
- external shunt resistor
 - noise reduction 1-16
 - wiring 3-22

F

- fiber optic cables C-6
 - receive and transmit connectors 3-26
- Fiber-optic cable installation instructions P-3
- flyback diodes B-19
- front panel connections 2-1, 2-4, 2-6, 2-8, 2-10, 2-12, 2-14, 2-16, 2-18, 2-20, 2-22, 2-24

- Ultra3000 2-2
- with DeviceNet 2-18
- with SERCOS 2-10
- fuse sizing 1-10
- fuse specifications A-5

G

- grounded power configuration 3-3
- grounding
 - cable shield (bottom of drive) 3-11
 - cable shield (front of drive) 3-11
 - multiple subpanels 3-10
 - system to subpanel 3-9

H

- heat losses for sizing enclosures A-7
- HF bonding
 - bonding practices 1-11
- high frequency energy 1-12

I

- I/O
 - connections 3-23
- input power 3-16
- input power wiring
 - 3-phase Delta 3-4
 - 3-phase WYE 3-3
 - determining input power 3-3
 - grounded power configuration 3-3
 - single-phase 3-5
 - single-phase amplifiers on 3-phase power 3-6, 3-7, 3-8
- installing your Ultra3000 1-1
- integration P-1
- integration manual P-3
- interconnect diagrams
 - controlling a brake example B-19
 - power B-3, B-4, B-5, B-6
 - shunt module B-7, B-8, B-9
 - Ultra3000 to 1326AB motors B-10
 - Ultra3000 to H- and F-series motor B-13

- Ultra3000 to IMC-S B-23
- Ultra3000 to Logix B-20
- Ultra3000 to MP-series motor B-10, B-11, B-12
- Ultra3000 to N-series motor B-14
- Ultra3000 to servo module B-21
- Ultra3000 to SoftLogix B-22
- Ultra3000 to Y-series motor B-15

- interface cables C-5

- introduction P-1

L

- LED
 - module status (DeviceNet) 4-10
 - module status (SERCOS) 4-9
 - network status (DeviceNet) 4-10
 - network status (SERCOS) 4-9
- LED indicator 4-3
- logic power LED 4-3
- Logix controller motion
 - instruction set reference manual P-3
- Low Voltage Directive 1-3

M

- maintenance
 - troubleshooting 4-3
- manuals on-line P-4
- maximum feedback cable length specifications A-13
- module status LED 4-9, 4-10
- Motion Book P-3
- motion control problem report form P-4
- Motion Control Selection Guide P-3
- motor encoder specifications AM, BM, and IM inputs 2-40
 - auxiliary encoder 2-49
 - connections 2-45
 - encoder phasing 2-44
 - Hall inputs 2-42
 - limit inputs 2-43
 - thermostat input 2-42
- motor feedback cables 3-24, C-5

- motor feedback specifications
 - A-10
 - motor power and brakes 3-18
 - motor power cables 3-19, 3-20, C-4
 - motors 3-24, 3-25
 - connector kits C-7
 - power wiring
 - Y-Series 3-11, 3-12
 - motors brake wiring 3-21
 - mounting
 - before mounting 1-5
 - external shunt resistor 1-16, 1-17
 - guidelines to reduce noise 1-15
 - HF bonding 1-10
 - procedure 1-18
 - system requirements 1-6
- N**
- network
 - cable system 3-29
 - data rate 3-29
 - network status LED (DeviceNet) 4-10
 - network status LED (SERCOS) 4-9
 - noise P-3
 - see HF bonding 1-10
 - noise zones 1-13, 1-14
 - notes B-2
- O**
- overload protection 3-15
- P**
- panel
 - cable categories 1-14
 - layout 1-12
 - noise zones
 - ControlLogix 1-14
 - Ultra3000 1-13
 - pin-outs
 - motor encoder connector 2-3, 2-5, 2-7, 2-9, 2-11, 2-13, 2-15, 2-17, 2-19, 2-21, 2-23, 2-25
 - motor feedback connector
 - 3-24, 3-25
 - serial connector 2-2, 2-4, 2-6, 2-8, 2-10, 2-12, 2-14, 2-16, 2-18, 2-20, 2-22, 2-24
 - Ultra3000 I/O connector 2-3, 2-5, 2-7, 2-9
 - with DeviceNet I/O connector 2-19, 2-21, 2-23, 2-25
 - with SERCOS I/O connector 2-11, 2-13, 2-15, 2-17
 - power
 - losses A-7
 - power diagrams
 - 2098-DSD-005, -010, -020 B-3
 - 2098-DSD-030 B-4
 - 2098-DSD-075, -150 B-5
 - 2098-DSD-HVxxx B-6
 - power dissipation A-7
 - power specifications A-2, A-3, A-4
 - preselect inputs 2-29
 - problem report form P-4
 - purpose of this manual P-1
- R**
- ready B-2
 - related documentation P-3
 - relay output B-2, B-3, B-4, B-5, B-6, B-16, B-19
 - routing power and signal wiring 3-2
 - RS-232 2-51, 2-52
 - RS-422 2-51, 2-53
 - RS-485 2-51, 2-52, 2-53
 - RSLogix 5000 software C-2
- S**
- serial interface specifications 2-51
 - default serial interface settings 2-52
 - four-wire RS-485 connection 2-53
 - multiple axes RS-232 communications 2-52
 - restoring drive communications 2-54
 - serial port 2-51
 - shunt module
 - catalog numbers C-3

- interconnect diagram B-7, B-8, B-9
- specifications A-12
- sizing an enclosure 1-8
- SoftLogix integration P-1
- SoftLogix motion card setup and configuration manual P-3
- specifications
 - ac line filters A-11
 - auxiliary +5V power supply 2-26
 - auxiliary encoder power supply 2-51
 - auxiliary feedback A-10
 - certifications A-1
 - circuit breakers A-6
 - communications A-9
 - connectors A-10
 - contactor ratings A-7
 - control A-8
 - digital I/O power supply 2-26
 - external +5V logic power supply 2-28
 - fuses A-5
 - I/O 2-26
 - I/O digital inputs 2-28
 - I/O digital outputs 2-34
 - inputs and outputs A-9
 - maximum feedback cable lengths A-13
 - motor encoder feedback 2-40
 - motor feedback A-10
 - physical and environmental A-8
 - power dissipation A-7
 - power, 230V A-2, A-3
 - power, 460V A-4
 - shunt modules A-12
- status LED 4-3
- storage
 - responsibility P-2
- support
 - comments regarding this manual P-4
 - local product P-4
 - technical product assistance P-4
- System Design for Control of Electrical Noise Reference Manual P-3
- system mounting requirements

- elevation 1-6
- fuse sizing 1-10
- minimum clearances 1-7
- sizing an enclosure 1-8
- transformer sizing 1-8
- ventilation 1-7

T

- TB1 terminal positions 3-14
- TB2 terminal positions 3-15
- terminal block connections 3-13, 3-14
- terminal positions, TB1 3-14
- terminal positions, TB2 3-15
- The Automation Bookstore P-1
- transformer sizing 1-8
- troubleshooting 4-3
 - DeviceNet
 - module status LED 4-10
 - network status LED 4-10
 - error codes 4-3
 - module status LED 4-9
 - SERCOS
 - module status LED 4-9
 - network status LED 4-9
- troubleshooting status indicators 4-1
- typical installation 1-3
 - Ultra3000 1-4
 - Ultra3000, DeviceNet 1-5
 - Ultra3000, SERCOS 1-4

U

- Ultra3000
 - component overview 1-3
 - troubleshooting status indicators 4-1
 - typical installation 1-4
 - DeviceNet 1-5
 - SERCOS 1-4
- Ultra3000 accessories
 - catalog numbers C-1
- Ultra3000 DeviceNet reference manual P-3
- Ultra3000 digital servo drives
 - integration manual P-3
- Ultra3000 drives C-2
- Ultraware CD installation
 - instructions P-3
- Ultraware software C-2

Ultraware user manual P-3
unpacking modules 1-5

V

ventilation 1-7

W

who should use this manual P-1

wiring

 building your own cables 3-2

 cable shield clamp 3-18

 connecting DeviceNet to a
 network 3-29

 connecting fiber-optic cables
 3-26

 connecting your DeviceNet
 cable 3-30

 external shunt resistor 3-22
 grounded power configuration
 3-3

 grounding 3-9

 I/O connections 3-23

 input power 3-16

 determining type 3-3

 motor brake 3-21

 motor power 3-11, 3-12, 3-19,
 3-20

 motor power and brakes 3-18

 power wiring requirements
 3-13, 3-14

 requirements 3-1

 routing power and signal
 wiring 3-2

 terminal block connections
 3-13, 3-14

Rockwell Automation Support

Rockwell Automation provides technical information on the Web to assist you in using its products.

At <http://www.rockwellautomation.com/support>, you can find technical manuals, technical and application notes, sample code and links to software service packs, and a MySupport feature that you can customize to make the best use of these tools. You can also visit our Knowledgebase at <http://www.rockwellautomation.com/knowledgebase> for FAQs, technical information, support chat and forums, software updates, and to sign up for product notification updates.

For an additional level of technical phone support for installation, configuration, and troubleshooting, we offer TechConnectSM support programs. For more information, contact your local distributor or Rockwell Automation representative, or visit <http://www.rockwellautomation.com/support/>.

Installation Assistance

If you experience a problem within the first 24 hours of installation, review the information that is contained in this manual. You can contact Customer Support for initial help in getting your product up and running.

United States or Canada	1.440.646.3434
Outside United States or Canada	Use the Worldwide Locator at http://www.rockwellautomation.com/support/americas/phone_en.html , or contact your local Rockwell Automation representative.

New Product Satisfaction Return

Rockwell Automation tests all of its products to ensure that they are fully operational when shipped from the manufacturing facility. However, if your product is not functioning and needs to be returned, follow these procedures.

United States	Contact your distributor. You must provide a Customer Support case number (call the phone number above to obtain one) to your distributor to complete the return process.
Outside United States	Please contact your local Rockwell Automation representative for the return procedure.

Documentation Feedback

Your comments will help us serve your documentation needs better. If you have any suggestions on how to improve this document, complete this form, publication [RA-DU002](#), available at <http://www.rockwellautomation.com/literature/>.

Rockwell Otomasyon Ticaret A.Ş., Kar Plaza İş Merkezi E Blok Kat:6 34752 İçerenköy, İstanbul, Tel: +90 (216) 5698400

www.rockwellautomation.com

Power, Control and Information Solutions Headquarters

Americas: Rockwell Automation, 1201 South Second Street, Milwaukee, WI 53204-2496 USA, Tel: (1) 414.382.2000, Fax: (1) 414.382.4444
Europe/Middle East/Africa: Rockwell Automation NV, Pegasus Park, De Kleetlaan 12a, 1831 Diegem, Belgium, Tel: (32) 2 663 0600, Fax: (32) 2 663 0640
Asia Pacific: Rockwell Automation, Level 14, Core F, Cyberport 3, 100 Cyberport Road, Hong Kong, Tel: (852) 2887 4788, Fax: (852) 2508 1846

Publication 2098-IN003E-EN-P - April 2004

Supersedes Publication 2098-IN003D-EN-P - May 2003

Copyright © 2004 Rockwell Automation, Inc. All rights reserved. Printed in the U.S.A.